



Electronic timers

CT-D range

1

Contents

Benefits and advantages.....	1/ 6
Ordering details	1/ 7
Function diagrams.....	1/ 9
Star-delta change-over.....	1/11
Connection diagrams	1/12
Technical data	1/13
Technical diagrams.....	1/15
Wiring notes	1/16
Dimensional drawings	1/16
Approvals and marks	1/ 4

Electronic timers CT-D range Benefits and advantages

1 CT-D range - the modular timers

Ideally suited for installation in distribution panels



2CDC 255 038 F0b06

- Diversity:
 - 2 multifunction timers
 - 10 single-function timers
- Control supply voltages:
 - Wide range: 12-240 V AC/DC
 - Multi range: 24-48 V DC, 24-240 V AC
- 7 time ranges, from 0.05 s to 100 h or 4 time ranges, from 0.05 s - 10 min
- Width of only 17.5 mm
- Light-grey enclosure in RAL 7035
- Devices with:
 - 1 c/o contact (250 V / 6 A) or 2 c/o contacts (250 V / 5 A)
 - Control input: voltage-related triggering, polarized, capable of switching a parallel load

■ Approvals / Marks (partly pending)



Direct reading scales

Direct setting of the time delay without any additional calculation provides accurate time delay adjustment.



2CDC 253 066 F0006



2CDC 253 132 F0006

LEDs for status indication

All actual operational states are displayed by front-face LEDs, thus simplifying commissioning and troubleshooting.

Connecting terminals

Wide terminal spacing allows connection of wires:

- 2 x 1.5 mm² (2 x 16 AWG) with wire end ferrules or
- 2 x 2.5 mm² (2 x 14 AWG) without ferrules.



2CDC 253 033 F0004

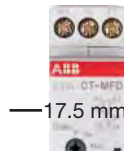

2CDC 253 021 F0004

Width 17,5 mm

With their width of 17.5 mm only, the CT-D range timers are ideally suited for installation in distribution panels.

Switching currents

The CT-D range timers allow an output load of up to 6 A on devices with 1 c/o contact and up to 5 A on devices with 2 c/o contacts.



2CDC 252 048 F0b06

Operating controls

① LEDs for status indication

U - green LED:
control supply voltage applied



R, R1, R2 - yellow LED:
output relay energized

② Time range adjustment

③ Fine adjustment of the time delay

④ Preselection of the timing function

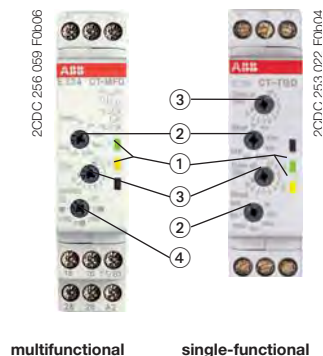

2CDC 256 038 F0b06

2CDC 253 022 F0b04

Synonyms

used expression	alternative expression(s)	used expression	alternative expression(s)
1 c/o contact	SPDT	voltage-related	wet / non-floating
2 c/o contacts	DPDT	volt-free	dry / floating

1/6

2CDC110004C0207



Electronic timers

CT-D range

Ordering details



CT-MFD.12



CT-MFD.21



CT-ERD.12



CT-ERD.22



CT-AHD.22

Type	Rated control supply voltage	Control input	Order code	Pack. unit pieces	Price 1 piece	Weight 1 piece kg / lb
------	------------------------------	---------------	------------	-------------------	---------------	------------------------

Multifunction timers

CT-MFD: 7 functions ¹⁾, 7 time ranges (0.05 s - 100 h), 1 c/o contact, 2 LEDs

CT-MFD.12	24-48 V DC, 24-240 V AC	■	1SVR 500 020 R0000	1		0.060 / 0.132
-----------	-------------------------	---	--------------------	---	--	---------------

CT-MFD: 7 functions ¹⁾, 7 time ranges (0.05 s - 100 h), 2 c/o contacts, 2 LEDs

CT-MFD.21	12-240 V AC/DC	■	1SVR 500 020 R1100	1		0.065 / 0.143
-----------	----------------	---	--------------------	---	--	---------------

ON-delay timers ☒

CT-ERD: 7 time ranges (0.05 s - 100 h), 1 c/o contact, 2 LEDs

CT-ERD.12	24-48 V DC, 24-240 V AC		1SVR 500 100 R0000	1		0.060 / 0.132
-----------	-------------------------	--	--------------------	---	--	---------------

CT-ERD: 7 time ranges (0.05 s - 100 h), 2 c/o contacts, 2 LEDs

CT-ERD.22	24-48 V DC, 24-240 V AC		1SVR 500 100 R0100	1		0.065 / 0.143
-----------	-------------------------	--	--------------------	---	--	---------------

OFF-delay timers ■

CT-AHD: 7 time ranges (0.05 s - 100 h), 1 c/o contact, 2 LEDs

CT-AHD.12	24-48 V DC, 24-240 V AC	■	1SVR 500 110 R0000	1		0.060 / 0.132
-----------	-------------------------	---	--------------------	---	--	---------------

CT-AHD: 7 time ranges (0.05 s - 100 h), 2 c/o contacts, 2 LEDs

CT-AHD.22	24-48 V DC, 24-240 V AC	■	1SVR 500 110 R0100	1		0.065 / 0.143
-----------	-------------------------	---	--------------------	---	--	---------------

¹⁾ Functions: ON-delay, OFF-delay with auxiliary voltage, Impulse-ON, Impulse-OFF with auxiliary voltage, Flasher starting with ON, Flasher starting with OFF, Pulse former

• Function diagrams..... 1/9	• Connection diagrams.....1/12	• Technical data..... 1/13
• Technical diagrams..... 1/15	• Wiring notes, Dimensional drawings1/16	• Wiring notes, Dimensional drawings1/16

Electronic timers

CT-D range

Ordering details

1



CT-VWD.12



CT-EBD.12



CT-TGD.12



CT-TGD.22



CT-SDD.22

Type	Rated control supply voltage	Control input	Order code	Pack. unit pieces	Price 1 piece	Weight 1 piece kg / lb
------	------------------------------	---------------	------------	-------------------	---------------	------------------------

Impulse-ON timers $\square \square \square$

CT-VWD: 7 time ranges (0.05 s - 100 h), 1 c/o contact, 2 LEDs

CT-VWD.12	24-48 V DC, 24-240 V AC		1SVR 500 130 R0000	1		0.060 / 0.132
-----------	----------------------------	--	--------------------	---	--	---------------

Flasher, starting with ON $\square \square \square$

CT-EBD: 7 time ranges (0.05 s - 100 h), 1 c/o contact, 2 LEDs

CT-EBD.12	24-48 V DC, 24-240 V AC		1SVR 500 150 R0000	1		0.060 / 0.132
-----------	----------------------------	--	--------------------	---	--	---------------

Pulse generators $\square \square \square$

CT-TGD: 2 x 7 time ranges (0.05 s - 100 h)²⁾, 1 c/o contact, 2 LEDs

CT-TGD.12	24-48 V DC, 24-240 V AC	■	1SVR 500 160 R0000	1		0.060 / 0.132
-----------	----------------------------	---	--------------------	---	--	---------------

CT-TGD: 2 x 7 time ranges (0.05 s - 100 h)²⁾, 2 c/o contacts, 2 LEDs

CT-TGD.22	24-48 V DC, 24-240 V AC	■	1SVR 500 160 R0100	1		0.065 / 0.143
-----------	----------------------------	---	--------------------	---	--	---------------

Star-delta timers \triangle

CT-SDD: 4 time ranges (0.05 s - 10 min), transition time 50 ms fixed, 2 n/o contacts, 3 LEDs

CT-SDD.22	24-48 V DC, 24-240 V AC		1SVR 500 211 R0100	1		0.065 / 0.143
-----------	----------------------------	--	--------------------	---	--	---------------

CT-SAD: 4 time ranges (0.05 s - 10 min), transition time adjustable, 2 n/o contacts, 3 LEDs

CT-SAD.22	24-48 V DC, 24-240 V AC		1SVR 500 210 R0100	1		0.065 / 0.143
-----------	----------------------------	--	--------------------	---	--	---------------

²⁾ ON and OFF times adjustable independently: 2 x 7 time ranges 0.05 s - 100 h

• Function diagrams..... 1/9	• Connection diagrams.....1/12	• Technical data..... 1/13
• Technical diagrams..... 1/15	• Wiring notes, Dimensional drawings1/16	• Wiring notes, Dimensional drawings1/16

Electronic timers CT-D range Function diagrams

Remarks

Legend

- Control supply voltage not applied / Output contact open
- Control supply voltage applied / Output contact closed
- A1-Y1/B1 Control input with voltage-related triggering

Terminal designations on the device and in the diagrams

- The 1st c/o contact is always designated **15-16/18**.
- The 2nd c/o contact is designated **25-26/28**.
- The n/o contacts of the star-delta timers are designated with **17-18** and **17-28**.
- Control supply voltage is always applied to terminals **A1-A2**.

Function of the yellow LED

- The yellow LED **R** glows as soon as the output relay energizes and turns off when the output relay de-energizes.

⊠ ON-delay (Delay on make) CT-ERD, CT-MFD

This function requires continuous control supply voltage for timing. Timing begins when control supply voltage is applied. The green LED flashes during timing. When the selected time delay is complete, the output relay energizes and the flashing green LED turns steady. If control supply voltage is interrupted, the output relay de-energizes and the time delay is reset. Control input **A1-Y1/B1** of the CT-MFD is disabled when this function is selected.

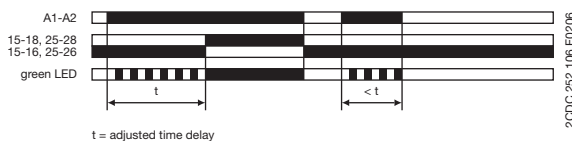

■ OFF-delay with auxiliary voltage (Delay on break) CT-AHD, CT-MFD

This function requires continuous control supply voltage for timing. If control input **A1-Y1/B1** is closed, the output relay energizes immediately. If control input **A1-Y1/B1** is opened, the time delay starts. The green LED flashes during timing. When the selected time delay is complete, the output relay de-energizes and the flashing green LED turns steady. If control input **A1-Y1/B1** recloses before the time delay is complete, the time delay is reset and the output relay does not change state. Timing starts again when control input **A1-Y1/B1** re-opens. If control supply voltage is interrupted, the output relay de-energizes and the time delay is reset.

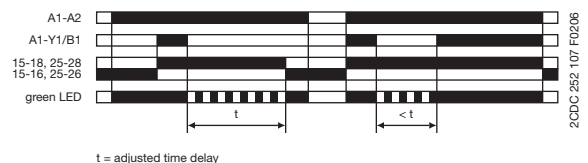

Electronic timers CT-D range Function diagrams

1

Impulse-ON (Interval) CT-VWD, CT-MFD

This function requires continuous control supply voltage for timing. The output relay energizes immediately when control supply voltage is applied and de-energizes after the set pulse time is complete. The green LED flashes during timing. When the selected pulse time is complete, the flashing green LED turns steady. If control supply voltage is interrupted, the output relay de-energizes and the time delay is reset. Control input **A1-Y1/B1** of the CT-MFD is disabled when this function is selected.

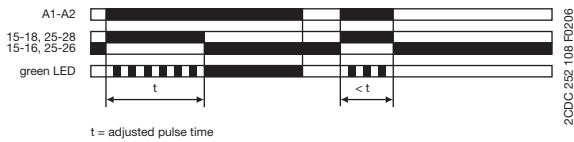

Impulse-OFF with auxiliary voltage (Trailing edge interval) CT-MFD

This function requires continuous control supply voltage for timing. If control supply voltage is applied, opening control input **A1-Y1/B1** energizes the output relay immediately and starts timing. The green LED flashes during timing. When the selected pulse time is complete, the output relay de-energizes and the flashing green LED turns steady. Closing control input **A1-Y1/B1**, before the time delay is complete, de-energizes the output relay and resets the time delay. If control supply voltage is interrupted, the output relay de-energizes and the time delay is reset.

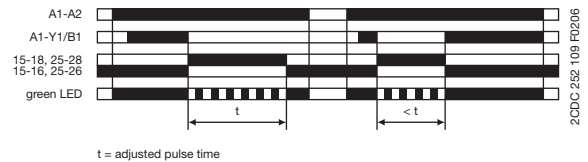

Flasher, starting with the ON time (Recycling equal times, ON first) CT-EBD, CT-MFD

Applying control supply voltage starts timing with symmetrical ON & OFF times. The cycle starts with an ON time first. The ON & OFF times are displayed by the flashing green LED, which flashes twice as fast during the OFF time. If control supply voltage is interrupted, the output relay de-energizes and the time delay is reset. Control input **A1-Y1/B1** of the CT-MFD is disabled when this function is selected.

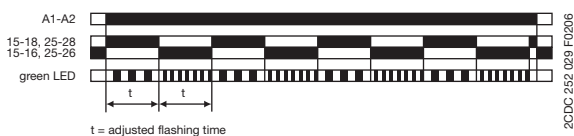

Flasher, starting with the OFF time (Recycling equal times, OFF first) CT-MFD

Applying control supply voltage starts timing with symmetrical ON & OFF times. The cycle starts with an OFF time first. The ON & OFF times are displayed by the flashing green LED, which flashes twice as fast during the OFF time. If control supply voltage is interrupted, the output relay de-energizes and the time delay is reset. Control input **A1-Y1/B1** of the CT-MFD is disabled when this function is selected.

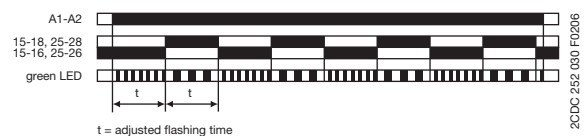

Electronic timers CT-D range Function diagrams

Pulse former (Single shot) CT-MFD

This function requires continuous control supply voltage for timing. Closing control input **A1-Y1/B1** energizes the output relay immediately and starts timing. Operating the control contact switch **A1-Y1/B1** during the time delay has no effect. The green LED flashes during timing. When the selected ON time is complete, the output relay de-energizes and the flashing green LED turns steady. After the ON time is complete, it can be restarted by closing control input **A1-Y1/B1**. If control supply voltage is interrupted, the output relay de-energizes and the time delay is reset.

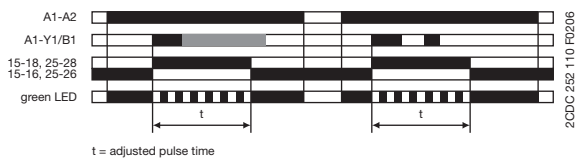

Pulse generator, starting with the ON or OFF time (Recycling unequal times, ON or OFF first) CT-TGD

This function requires continuous control supply voltage for timing. Applying control supply voltage, with open control input **A1-Y1/B1**, starts timing with an ON time first. Applying control supply voltage, with closed control input **A1-Y1/B1**, starts timing with an OFF time first. The ON & OFF times are displayed by the flashing green LED, which flashes twice as fast during the OFF time. The ON & OFF times are independently adjustable. If control supply voltage is interrupted, the output relay de-energizes and the time delay is reset.

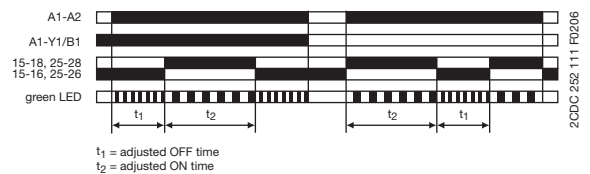

Star-delta change-over (Star-delta starting) CT-SDD, CT-SAD

This function requires continuous control supply voltage for timing. Applying control supply voltage to terminals **A1-A2**, energizes the star contactor connected to terminals **17-18** and begins the set starting time t_1 . The green LED flashes during timing. When the starting time is complete, the first output contact de-energizes the star contactor. Now, the transition time t_2 starts. When the transition time is complete, the second output contact energizes the delta contactor connected to terminals **17-28**. The delta contactor remains energized as long as control supply voltage is applied to the unit.

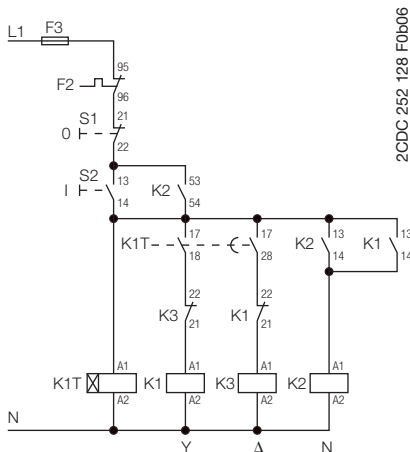
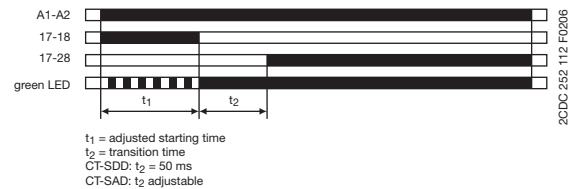

Control circuit diagram

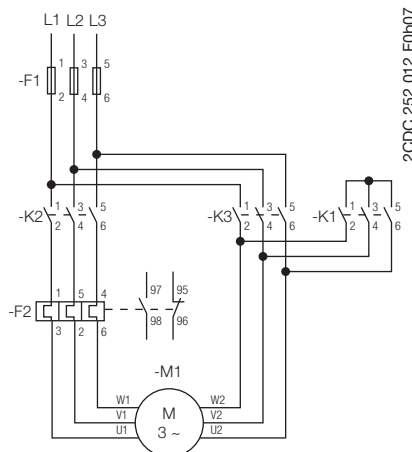

Power circuit diagram

Electronic timers CT-D range Connection diagrams

1

CT-MFD.21

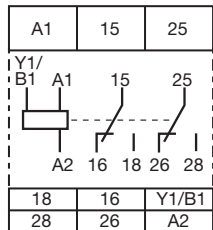

2CDC 252 113 F0b06

A1-A2 Supply: 12-240 V AC/DC
15-16/18 1. c/o contact
25-26/28 2. c/o contact
A1-Y1/B1 Control input

CT-MFD.12

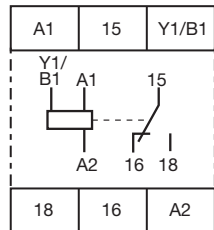

2CDC 252 114 F0b06

A1-A2 Supply: 24-48 V DC or 24-240 V AC
15-16/18 1. c/o contact
A1-Y1/B1 Control input

CT-ERD.22

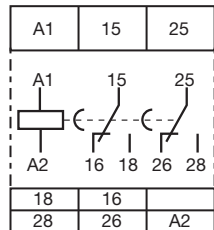

2CDC 252 115 F0b06

A1-A2 Supply: 24-48 V DC or 24-240 V AC
15-16/18 1. c/o contact
25-26/28 2. c/o contact

CT-ERD.12

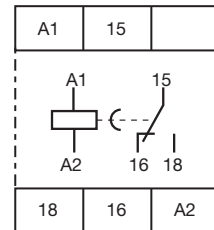

2CDC 252 177 F0b05

A1-A2 Supply: 24-48 V DC or 24-240 V AC
15-16/18 1. c/o contact

CT-AHD.22

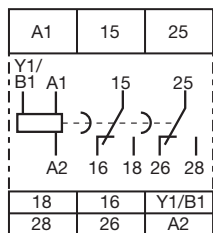

2CDC 252 116 F0b06

A1-A2 Supply: 24-48 V DC or 24-240 V AC
15-16/18 1. c/o contact
25-26/28 2. c/o contact
A1-Y1/B1 Control input

CT-AHD.12

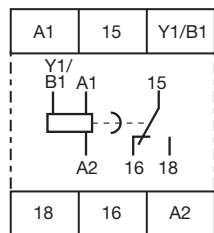

2CDC 252 117 F0b06

A1-A2 Supply: 24-48 V DC or 24-240 V AC
15-16/18 1. c/o contact
A1-Y1/B1 Control input

CT-VVD.12

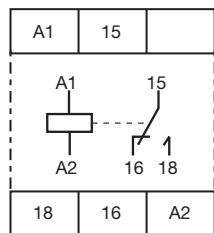

2CDC 252 179 F0b05

A1-A2 Supply: 24-48 V DC or 24-240 V AC
15-16/18 1. c/o contact

CT-EBD.12

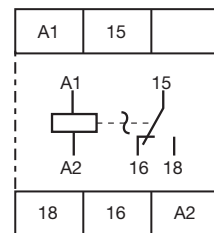

2CDC 252 180 F0b05

A1-A2 Supply: 24-48 V DC or 24-240 V AC
15-16/18 1. c/o contact

CT-TGD.22

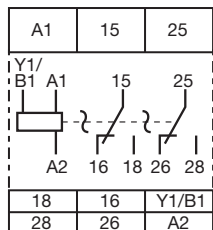

2CDC 252 118 F0b06

A1-A2 Supply: 24-48 V DC or 24-240 V AC
15-16/18 1. c/o contact
25-26/28 2. c/o contact
A1-Y1/B1 Control input

CT-TGD.12

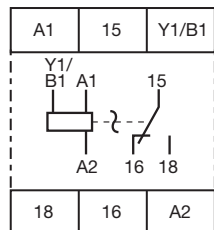

2CDC 252 119 F0b06

A1-A2 Supply: 24-48 V DC or 24-240 V AC
15-16/18 1. c/o contact
A1-Y1/B1 Control input

CT-SDD.22

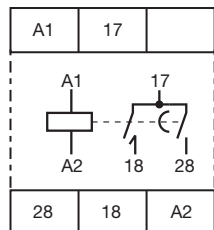

2CDC 252 160 F0b06

A1-A2 Supply: 24-48 V DC or 24-240 V AC
17-18 1. n/o contact (star contactor)
17-28 2. n/o contact (delta contactor)

CT-SAD.22

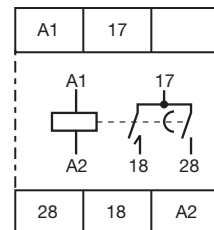

2CDC 252 160 F0b06



A1-A2 Supply: 24-48 V DC or 24-240 V AC
17-18 1. n/o contact (star contactor)
17-28 2. n/o contact (delta contactor)

Electronic timers

CT-D range

Technical data

Data at $T_a = 25\text{ °C}$ and rated values, unless otherwise indicated

Type		CT-D with 1 c/o contact	CT-D with 2 c/o contacts
Input circuit - Supply circuit			
Rated control supply voltage U_s	A1-A2	24-240 V AC / 24-48 V DC	
	A1-A2	-	12-240 V AC/DC (CT-MFD.21)
Rated control supply voltage U_s tolerance		-15...+10 %	
Rated frequency	AC/DC versions	DC or 50/60 Hz	
	AC versions	50/60 Hz	
Frequency range	AC/DC versions	DC or 47-63 Hz	
	AC versions	47-63 Hz	
Typical current / power consumption	24 V DC	- / 0.6 W	see data sheet
	230 V AC	- / 1.3 VA	see data sheet
	115 V AC	- / 1.3 VA	see data sheet
Power failure buffering time		min. 20 ms	min. 30 ms
Input circuit - Control circuit			
Kind of triggering		voltage-related triggering	
Control input, Control function	A1-Y1/B1	start timing external	
Parallel load / polarized		yes / yes	
Maximum cable length to the control input		50 m - 100 pF/m	
Minimum control pulse length		30 ms	
Control voltage potential		see rated control supply voltage	
Current consumption of the control input		max. 4 mA	see data sheet
Timing circuit			
Time ranges	7 time ranges 0.05 s - 100 h	1.) 0.05-1 s 4.) 0.5-10 min	2.) 0.5-10 s 5.) 5-100 min 7.) 5-100 h
	4 time ranges 0.05 s - 10 min (CT-SDD, CT-SAD)	1.) 0.05-1 s	2.) 0.5-10 s 4.) 0.5-10 min
Recovery time		< 50 ms	
Accuracy within the rated control supply voltage tolerance		$\Delta t < 0.005\% / V$	
Accuracy within the temperature range		$\Delta t < 0.06\% / \text{°C}$	
Repeat accuracy (constant parameters)		$\Delta t < \pm 0.5\%$	
Star-delta transition time	CT-SDD	fixed 50 ms	
	CT-SAD	adjustable: 20 -100 ms in steps of 10 ms	
Star-delta transition time tolerance	CT-SDD, CT-SAD	$\pm 3\text{ ms}$	
Indication of operational states			
Control supply voltage / timing	U: green LED	 : control supply voltage applied  : timing	
Relay status	R: yellow LED	 : output relay 1 or 2 energized	
Output circuit			
Kind of output	15-16/18	relay, 1 c/o contact	-
	15-16/18; 25-26/28	-	relay, 2 c/o contacts
	17-18; 17-28	relay, 2 n/o contacts (CT-SDD, CT-SAD)	
Contact material		Cd-free, see data sheet	
Rated operational voltage U_o	IEC/EN 60947-1	250 V	
Minimum switching voltage / minimum switching current		12 V / 100 mA	
Maximum switching voltage / maximum switching current		see load limit curves	
Rated operational current I_o (IEC/EN 60947-5-1)	AC12 (resistive) at 230 V	6 A	5 A
	AC15 (inductive) at 230 V	3 A	3 A ¹⁾
	DC12 (resistive) at 24 V	6 A	5 A
	DC13 (inductive) at 24 V	2 A	2 A ¹⁾

¹⁾ CT-MFD.21: Rated operational current AC15 (n/c contact) = 0.75 A; Rated operational current DC13 = 1 A

²⁾ CT-MFD.21 (n/c contact): Utilization category = C 300, max. continuous thermal current at C 300 = 2.5 A, Make / Break at C 300 = 1800/180 VA

Electronic timers

CT-D range

Technical data

1

Data at $T_a = 25\text{ °C}$ and rated values, unless otherwise indicated

Type		CT-D with 1 c/o contact	CT-D with 2 c/o contacts
AC rating (UL 508)	Utilization category (Control Circuit Rating Code)	B 300	B 300 ²⁾
	max. rated operational voltage	300 V AC	
	max. continuous thermal current at B 300	5 A	5 A ²⁾
	max. making /breaking apparent power at B 300	3600/360 VA	3600/360 VA ²⁾
Mechanical lifetime	30 x 10 ⁶ switching cycles		
Electrical lifetime	at AC12, 230 V, 4 A 0.1 x 10 ⁶ switching cycles		
Max. fuse rating to achieve short-circuit protection (IEC/EN 60947-5-1)	n/c contact	6 A fast-acting	
	n/o contact	10 A fast-acting	
General data			
Duty time	100%		
Dimensions (W x H x D)	17.5 x 70 x 58 mm (0.69 x 2.76 x 2.28 in)	17.5 x 80 x 58 mm (0.69 x 3.15 x 2.28 in)	
Weight	see ordering details		
Mounting	DIN rail (IEC/EN 60715), snap-mounting without any tool		
Mounting position	any		
Minimum distance to other units	horizontal / vertical	no / no	
Degree of protection	enclosure / terminals	IP50 / IP20	
Electrical connection			
Wire size	fine-strand with(out) wire end ferrule	2 x 0.5-1.5 mm ² (2 x 20-16 AWG) 1 x 0.5-2.5 mm ² (1 x 20-14 AWG)	
	rigid	2 x 0.5-1.5 mm ² (2 x 20-16 AWG) 1 x 0.5-4 mm ² (1 x 20-12 AWG)	
Stripping length	7 mm (0,28 in)		
Tightening torque	0.5-0.8 Nm		
Environmental data			
Ambient temperature range	operation / storage	-20 ... +60 °C / -40 ... +85 °C	
Damp heat (cyclic) (IEC/EN 60068-2-30)	6 x 24 h cycles, 55 °C, 95 % RH		
Vibration (sinusoidal) (IEC/EN 60068-2-6)	40 m/s ² , 20 cycles, 10...150...10 Hz		
Shock (half-sine) (IEC/EN 60068-2-27)	100 m/s ² , 11 ms		
Isolation data			
Rated impulse withstand voltage U_{imp} between all isolated circuits (VDE 0110, IEC/EN 60664-1)	4 kV; 1.2/50 µs		
Pollution category (IEC/EN 60664-1, VDE 0110, UL 508)	3		
Overvoltage category (IEC/EN 60664-1, VDE 0110, UL 508)	III		
Rated insulation voltage U_i	input circuit / output circuit	300 V	
	output circuit 1 / output circuit 2	300 V	
Basic insulation (IEC/EN 61140)	input circuit / output circuit	300 V	
Protective separation (VDE 0106 part 101 and part 101/A1; IEC/EN 61140)	input circuit / output circuit	250 V	
Power-frequency withstand voltage test (test voltage, routine test) between all isolated circuits	2.5 kV, 50 Hz, 1 s		
Standards			
Product standard	IEC 61812-1, EN 61812-1 + A11, DIN VDE 0435 part 2021		
Low Voltage Directive	2006/95/EC		
EMC Directive	2004/108/EC		
RoHS Directive	2002/95/EC		
Electromagnetic compatibility			
Interference immunity to	IEC/EN 61000-6-1, IEC/EN 61000-6-2		
electrostatic discharge	IEC/EN 61000-4-2	Level 3 (6 kV / 8 kV)	
radiated, radio-frequency, electromagnetic field	IEC/EN 61000-4-3	Level 3 (10 V/m)	
electrical fast transient / burst	IEC/EN 61000-4-4	Level 3 (2 kV / 5 kHz)	
surge	IEC/EN 61000-4-5	Level 4 (2 kV L-L)	
conducted disturbances, induced by radio-frequency fields	IEC/EN 61000-4-6	Level 3 (10 V)	
Interference emission	IEC/EN 61000-6-3, IEC/EN 61000-6-4		
high-frequency radiated	IEC/CISPR 22, EN 55022	Class B	
high-frequency conducted	IEC/CISPR 22, EN 55022	Class B	

Electronic timers CT-D range Technical diagrams

Technical diagrams

Load limit curves

AC load (resistive)

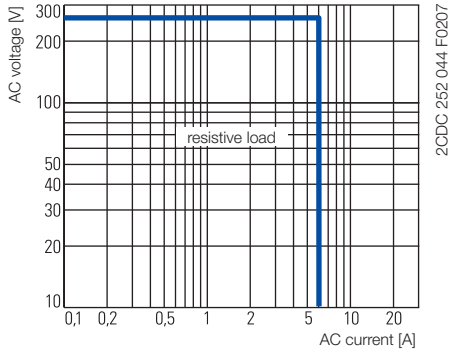

CT-D.1x

DC load (resistive)

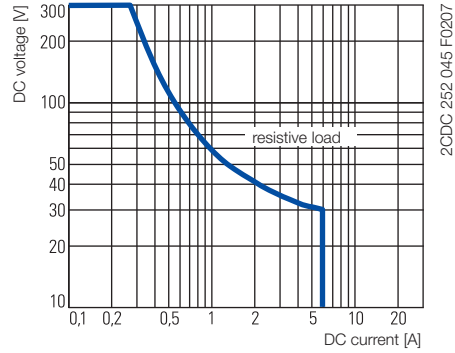

CT-D.1x

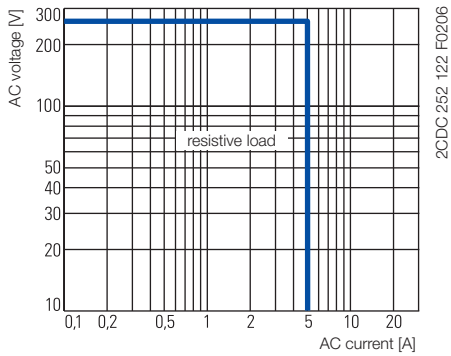

CT-D.2x

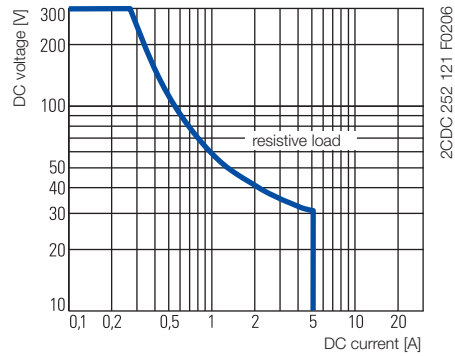

CT-D.2x

Derating factor F for inductive AC load

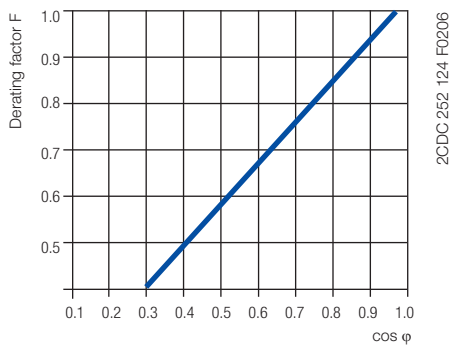

Contact lifetime

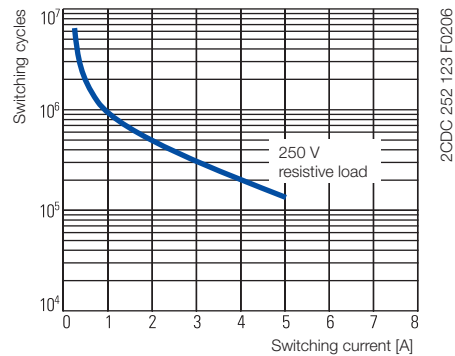

Electronic timers CT-D range

Wiring notes, Dimensional drawings

1

Wiring notes for devices with control input

A parallel load to the control input is possible

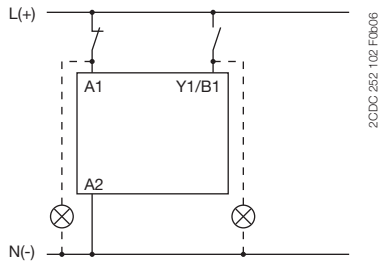

Dimensional drawings

dimensions in mm

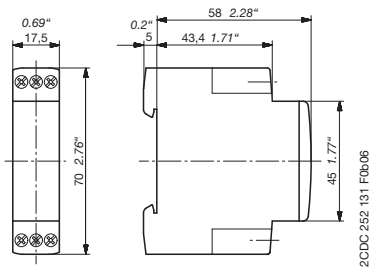

CT-D devices with 1 c/o contact or 2 n/o contacts

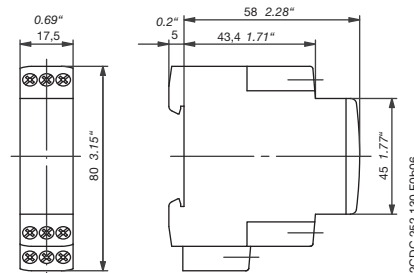

CT-D devices with 2 c/o contacts