

# Motor load monitors

## Fields of application

The motor load monitor monitors the load states of single-phase and three-phase asynchronous motors. The evaluation of the phase angle between current and voltage allows a very precise monitoring of the load states.

Compared with other conventional measuring principles (e.g. pressure transducers, current measurement),  $\cos \varphi$  monitoring is a more precise and economical alternative. The motor is used as a sensor for its own load status.

### Main applications

- Pump monitoring
  - Dry-running protection (underload)
  - Closed valves (overload)
  - Pipe break (overload)
- Heating, air-conditioning, ventilation
  - Monitoring of filter pollution
  - V-belt breakage (underload)
  - Closed shutters/valves (overload)
  - Air ventilating volume
- Agitating machines
  - High consistency within the tank (overload)
  - Pollution of the tank (overload)
- Transport/Conveyance
  - Congested conveyor belts (overload)
  - Jamming of belts (overload)
  - Material accumulation in spiral conveyors (overload)
  - Lifting platforms
- Machine installation
  - Wear of tools, e.g. worn saw blades in circular saws, etc. (overload)
  - Tool breakage (underload)
  - V-belt drives (breakage underload)

### Pump control

#### Dry-running protection

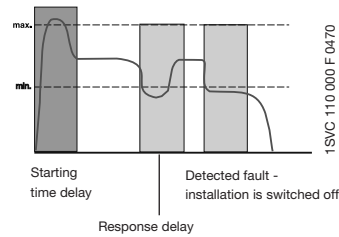

#### Filter pollution

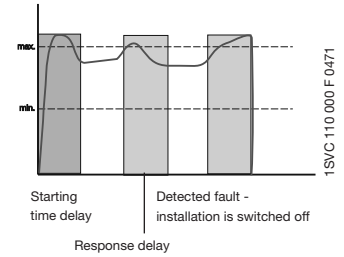

### Ventilator monitoring

#### V-belt monitoring

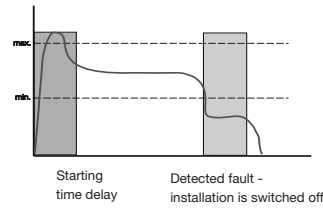

#### Filter pollution

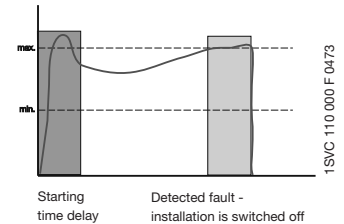

### Wiring examples (for motor currents $\leq 20$ A)

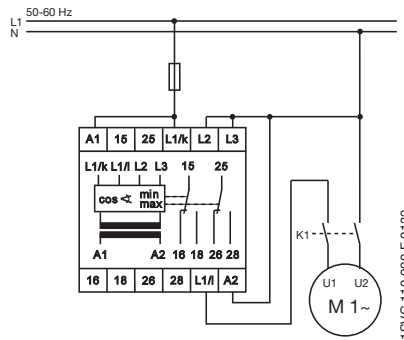
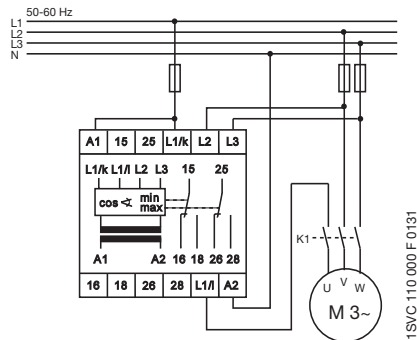

### Wiring examples (for motor currents $\geq 20$ A)

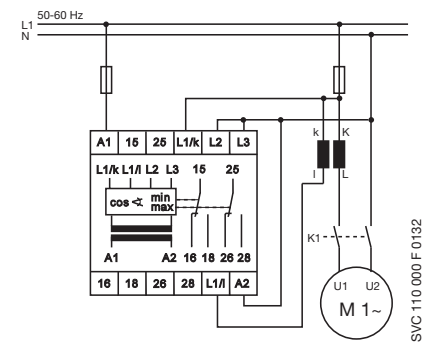
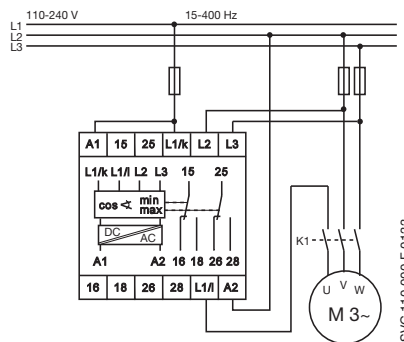
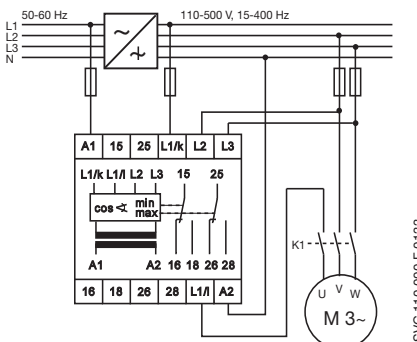
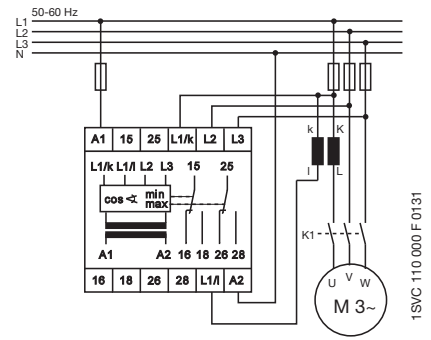

• Current transformers ..... 2/105

# Motor load monitors

## CM-LWN

### Ordering details



1SVR 450 335 F0100



#### CM-LWN

- ① Response delay "Time R"
- ② Threshold for load limit "cos  $\varphi_{min}$ "
- ③ cos  $\varphi_{max}$ : red LED - cos  $\varphi_{max}$  exceeded
- ④ cos  $\varphi_{min}$ : red LED - below cos  $\varphi_{min}$
- ⑤ Reset button
- ⑥ U: green LED - Control supply voltage
- ⑦ Threshold for load limit "cos  $\varphi_{max}$ "
- ⑧ Starting delay "Time S"
- ⑨ Marker label

- Load status monitoring for asynchronous motors
- Under- and overload monitoring cos  $\varphi_{min}$  and cos  $\varphi_{max}$  in one unit
- Adjustable starting delay 0.3-30 s
- Direct measurement of currents up to 20 A
- Adjustable response time delay 0.2-2 s
- Single-phase or three-phase monitoring
- 2 x 1 c/o contact, closed-circuit principle
- 3 LEDs for status indication

The **CM-LWN** module monitors the load status of inductive loads.

The primary application is the monitoring of single- or three-phase asynchronous motors (squirrel cage) under varying load conditions. The measuring principle is based on the evaluation of the phase shift ( $\varphi$ ) between the voltage and the current in one phase.

The phase difference is nearly inversely proportional to the load. Therefore, cos  $\varphi$ , measured relatively from 0 to 1, measures the relationship of effective power to apparent power. A value towards 0 indicates low load and a value towards 1 indicates high load.

Threshold values can be set individually for cos  $\varphi_{max}$  and cos  $\varphi_{min}$ . If the set threshold value is reached, a LED lights up and the relay is de-energized.

If cos  $\varphi$  returns to the acceptable limits (taking into account the hysteresis), the relay is reset to its original state and the LED flashes permanently to indicate the occurrence of the trip event. This message can be deleted using the reset button or by switching off the supply.

A time delay (Time S) of 0.3 to 30 s can be set for the starting phase of the motor. It is also possible to set a response delay time (Time R) of 0.2 to 2 s to suppress unwanted tripping due to unavoidable short load changes during normal operation.

To guarantee correct operation of the response delay (Time R), the adjusted value for cos  $\varphi_{max}$  has to be higher than the value for cos  $\varphi_{min}$  plus the hysteresis. Consequently, the overload and underload indication must not be active at the same time.

Due to the internal electrical isolation of the supply circuit and the measuring circuit, it is also possible to use the device in systems with different supply voltages.

#### Function diagram CM-LWN

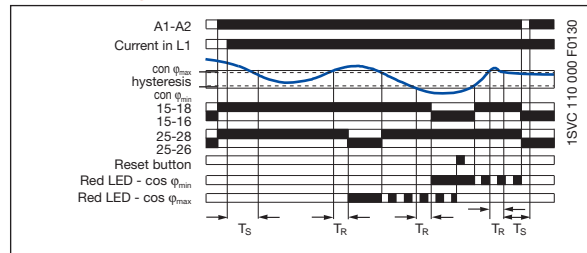

#### Connection diagram CM-LWN

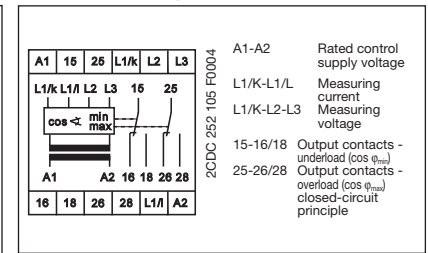

Type	Rated control supply voltage	Order code	Pack. unit pieces	Price 1 piece	Weight 1 piece kg / lb
------	------------------------------	------------	-------------------	---------------	------------------------

#### Current range: 0.5-5 A

<b>CM-LWN</b>	24-240 V AC/DC	<b>1SVR 450 335 R0000</b>	1		0.30 / 0.66
	110-130 V AC	<b>1SVR 450 330 R0000</b>	1		0.30 / 0.66
	220-240 V AC	<b>1SVR 450 331 R0000</b>	1		0.30 / 0.66
	380- 440 V AC	<b>1SVR 450 332 R0000</b>	1		0.30 / 0.66
	480-500 V AC	<b>1SVR 450 334 R0000</b>	1		0.30 / 0.66

#### Current range: 2-20 A

<b>CM-LWN</b>	24-240 V AC/DC	<b>1SVR 450 335 R0100</b>	1		0.30 / 0.66
	110-130 V AC	<b>1SVR 450 330 R0100</b>	1		0.30 / 0.66
	220-240 V AC	<b>1SVR 450 331 R0100</b>	1		0.30 / 0.66
	380-440 V AC	<b>1SVR 450 332 R0100</b>	1		0.30 / 0.66
	480-500 V AC	<b>1SVR 450 334 R0100</b>	1		0.30 / 0.66

• Technical data ..... 2/62	• Technical diagrams ..... 2/102	• Dimensional drawings ..... 2/103
• Accessories ..... 2/104	• Current transformers ..... 2/105	

# Motor load monitors

## CM-LWN

### Technical data

2

Type		CM-LWN	
<b>Input circuit - Supply circuit</b>		<b>A1-A2</b>	
Rated control supply voltage $U_s$ - power consumption	A1-A2	24-240 V AC/DC	approx. 8.4 VA/W
	A1-A2	110-130 V AC	approx. 3.6 VA
	A1-A2	220-240 V AC	approx. 3.6 VA
	A1-A2	380-440 V AC	approx. 3.6 VA
	A1-A2	480-500 V AC	approx. 3.6 VA
Rated control supply voltage $U_s$ tolerance		-15 %...+10 %	
Rated frequency	AC versions	50-60 Hz	
	AC/DC versions	15-400 Hz or DC	
Duty time		100 %	
<b>Measuring circuit</b>		<b>L1/L-L1/K-L2-L3</b>	
Monitoring function		Motor load monitoring by $\cos \varphi$	
Voltage range	L1/K-L2-L3	110-500 V AC single-phase or three-phase	
Current range	L1/L-L1/K	0.5-5 A version	2-20 A version
Permissible overload of current input		25 A for 3 s	100 A for 3 s
Thresholds		$\cos \varphi_{\min}$ and $\cos \varphi_{\max}$ adjustable from 0 to 1	
Hysteresis (related to phase angle $\varphi$ in °)		4°	
Frequency of measuring voltage		15-400 Hz	
Response time		300 ms	
<b>Timing circuits</b>		<b>indication of over- and undervoltage fault</b>	
Start-up time (Time S)		0.3-30 s, adjustable	
Response delay (Time R)		0.2-2 s, adjustable	
Accuracy within the rated control supply voltage tolerance		$\Delta t \leq 0.5 \%$	
Accuracy within the temperature range		$\Delta t \leq 0.06 \%$ / °C	
<b>Indication of operational states</b>			
Control supply voltage		U: green LED	
below $\cos \varphi_{\min}$		$\cos \varphi_{\min}$ : red LED	
$\cos \varphi_{\max}$ exceeded		$\cos \varphi_{\max}$ : red LED	
<b>Output circuits</b>		<b>15-16/18, 25-26/28</b>	
Kind of output		2 x 1 c/o contact	
Operational principle <sup>1)</sup>		closed-circuit principle	
Contact material		AgCdO	
Rated voltage (VDE 0110, IEC 664-1, IEC 947-1)		250 V	
Max. switching voltage		400 V AC, 300 V DC	
Rated operational current $I_b$ (IEC/EN 60947-1)	AC12 (resistive) 230 V	4 A	
	AC15 (inductive) 230 V	3 A	
	DC12 (resistive) 24 V	4 A	
	DC13 (inductive) 24 V	2 A	
AC rating (UL 508)	Utilization category (Control Circuit Rating Code)	B 300	
	max. rated operational voltage	300 V AC	
	max. continuous thermal current at B 300	5 A	
	max. making/breaking apparent power at B 300	3600/360 VA	
Mechanical lifetime		30 x 10 <sup>6</sup> switching cycles	
Electrical lifetime at AC12, 230 V, 4 A		0.1 x 10 <sup>6</sup> switching cycles	
Max. fuse rating to achieve short circuit protection n/c / n/o contact		10 A fast-acting / 10 A fast-acting	
<b>General data</b>			
Dimensions (W x H x D)		45 mm x 78 mm x 100 mm (1.77 inch x 3.07 inch x 3.94 inch)	
Mounting position		any	
Degree of protection enclosure / terminals		IP50 / IP20	
Ambient temperature range operation / storage		-25...+65 °C / -40...+85 °C	
Mounting		DIN rail (IEC/EN 60715)	
<b>Electrical connection</b>			
Wire size	fine-strand with wire end ferrule	2 x 2.5 mm <sup>2</sup> (2 x 14 AWG)	
<b>Standards</b>			
Product standard		IEC 255-6, EN 60255-6	
Low Voltage Directive		2006/95/EC	
EMC Directive		2004/108/EC, 91/263/EEC, 92/31/EEC, 93/68/EEC, 93/67/EEC	
Electromagnetic compatibility		EN 61000-6-2, EN 61000-6-4	
electrostatic discharge	IEC/EN 61000-4-2	Level 3 (6 kV / 8 kV)	
radiated, radio-frequency, electromagnetic field	IEC/EN 61000-4-3	Level 3 (10 V/m)	
electrical fast transient / burst	IEC/EN 61000-4-4	Level 3 (2 kV / 5 kHz)	
surge	IEC/EN 61000-4-5	Level 4 (2 kV L-L)	
conducted disturbances, induced by radio-frequency fields	IEC/EN 61000-4-6	Level 3 (10 V)	
Operational reliability (IEC 68-2-6)		5 g	
Mechanical resistance (IEC 68-2-6)		10 g	
Environmental testing (IEC 68-2-30)		24 h cycle time, 55 °C, 93 % rel., 96 h	
<b>Isolation data</b>			
Rating (HD 625.1 S1, VDE 0110, IEC 664-1, IEC 60255-5)			
Rated insulation voltage between supply-, measuring- and output circuit		250 V, 400 V, 500 V depending on the version	
Rated impulse withstand voltage between all isolated circuits		4 kV / 1.2 - 50 $\mu$ s	
Test voltage between all isolated circuits		2,5 kV, 50 Hz, 1 min.	
Pollution category		3	
Overvoltage category		III	

<sup>1)</sup> Open-circuit principle: Output relay is energized if the measured value exceeds/drops below the adjusted threshold.  
 Closed-circuit principle: Output relay is de-energized if the measured value exceeds/drops below the adjusted threshold.