

# Safety PLC

# Pluto AS-i

## Approvals:



## Control of:

- Safety products in dynamic and static circuits as well as in AS-i networks
- Electrically controlled actuators such as contactors, valves, motors
- Indicators and buttons

## Features:

- AS-i interface where up to 31 safety products can be connected
- Dispersed constructions of machines
- Great flexibility
- Up to 10 sensors in series connected to one input
- Software Pluto Manager free of charge
- Handles conventional circuit breakers as well as dynamical sensors
- Custom made safety bus
- Very large systems can be monitored by Pluto AS-i



### A safety PLC for AS-i Safety

Pluto AS-i is a safety PLC designed for the AS-i Safety concept where all the safety components are connected to a single cable. Pluto AS-i has the same characteristics as a standard Pluto and works in the same way with the only difference being the AS-i bus. As with a standard Pluto, Pluto AS-i is in an All-Master system with its own safety bus and is designed for dynamic and static safety circuits where inputs and other information are shared across the bus. Pluto AS-i also has a reduced number of failsafe inputs (I), failsafe relay and transistor outputs (Q) and terminals that are user-defined and serve as failsafe inputs or non-failsafe outputs (IO).

For the AS-i bus, Pluto AS-i acts as a master, monitor, or I/O controller. As a master it controls and distributes all communication while it works as a monitor. In monitor mode, it listens to the bus and controls its safe outputs. As an I/O controller it serves as a slave node on the AS-i bus and communicates with another master or monitor.

### Pluto AS-i is available in two models

ABB Jokab Safety's Pluto AS-i is available in two different models. A smaller version, Pluto AS-i, and a larger model with a larger number of I/Os, Pluto B42 AS-i. Both models have a model-dependent number of I/Os. If more I/Os are necessary, you can connect Pluto AS-i to Pluto B16, B20 or B46 via the Pluto safety bus.

### Pluto AS-i is programmed using Pluto Manager

Programming Pluto AS-i is made easy using TÜV-reviewed software with ladder language and finished blocks for various safety functions. The Pluto Manager software is also free to download from our website.

## Technical information – Pluto AS-i

### I/O properties

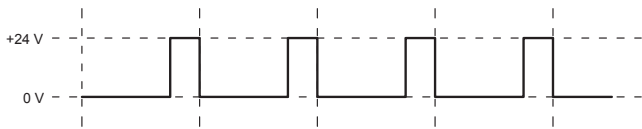

A dynamic signal makes it possible to achieve PL e as specified in 13849-1 with only one conductor. By transmitting a square wave and then evaluating the signal when it comes back to the controller you achieve the redundancy required. The kind of signal Pluto expects at the input terminal is determined in Pluto Manager (A or B pulse and if the signal is to be inverted or not).

Static signals (+24 V or 0 V) can be connected to all inputs on Pluto. The kind of signal Pluto expects at the terminal input is determined in Pluto Manager.

There are safety products with internal monitoring of dual OSSD signals (the device detects its own faults rather than Pluto doing this). From these devices, at least one of the two signals is connected to an I-input in Pluto, i.e. both signals must not be connected to the IQ-terminals.

The IQ-terminals can be used either as individual failsafe inputs or as non-failsafe outputs (e.g. for indicator lamp or status signal). The terminal blocks can also be used as both input and output simultaneously, which is useful for example for push buttons (input) with indicator lamp (output). This function is designed primarily for reset buttons to reduce the number of used inputs on the controller. The terminal block's I/O characteristics are determined in Pluto Manager.

All inputs are individually failsafe as each input is connected separately to both processors in Pluto. In order to maintain the redundancy required for a two-channel structure and PL e in compliance with 13849-1, the dynamic signal must be used. The expected signal to the terminals is also determined in Pluto Manager (static or dynamic signal).

All Q outputs are individually safe and are independently programmable.

The transistor outputs are just like the relay outputs, that is individually safe and independently programmable. However, the transistor outputs are different from the relay outputs as the internal connection provides the nominal input voltage -24 VDC, which is primarily intended for controlling electromechanical components such as contactors and valves.

### Safety bus

The safety bus is a modified CAN-bus and the bus cable can be up to 600 m long at the lowest bus speed. At 400 kb/s the bus can be up to 150 m. Note that the maximum length of the bus depends on whether and how the joints are used. The bus can be both extended and connected to other types of buses through gateways.

### AS-i bus

The AS-i bus is also a safe bus where safety is based on an alternating code table. The bus can be up to 500 m in length provided that the bus master is placed in the middle of the loop. Each AS-i branch should not be longer than 100 m. The loop can be extended by using repeaters. However, there should not be more than two repeaters attached in series due to time constraints.

All safety components that are connected to the AS-i loop take a complete address and are interpreted as slaves. The AS-i bus can handle 31 different addresses where each address can be divided into an A and B slave for non safety I/O. A separate power supply unit with about 30V DC is required for the AS-i bus.

## Pluto Manager and ID-fix

### Pluto manager

The Pluto Manager is freeware for fast, easy and safe programming of the PLC program for Pluto. The programming language used is ladder, which is supplemented with TÜV-approved function blocks for many common features. The software can also be used to configure Pluto's terminal blocks, e.g. the IQ terminals that serve as inputs or outputs are specified and the controller should expect a static or dynamic signal. Pluto Manager can be downloaded from [ABB website](http://ABB website).

### ID-fix

ID-fix is an identification circuit that is unique to each device on the Pluto bus. It includes an identification code and makes it possible to distribute a PLC program in the network and to address Pluto units. There are four different versions: R, R/W, R/W/Data and PROG. In addition to the identification code, R/W/Data may also include safety codes from the AS-i nodes in an AS-i system. PROG includes the current PLC program and is used together with Pluto for program distribution. ID fix is connected between the input terminals ID and 0V.

## Pluto AS-i

### A Pluto AS-i can be used in three ways - as Safety Master, Safety Monitor or as Safety I/O

#### 1. Pluto as Safety Master\*

The master distributes and controls communication on the AS-i bus and acts simultaneously as Safety Monitor.

#### 2. Pluto as Safety Monitor\*

The monitor listens to what is happening on the AS-i bus and controls the safe outputs.

#### 3. Pluto as Safety I/O\*

Multiple safe inputs and/or outputs are controlled and communicate with a safe master or monitor across the AS-i bus.

\*Whether Pluto is used as a Master, Monitor or I/O it can simultaneously control and monitor the safety of a machine.

#### Gateway

Gateways allow you to communicate easily with other bus systems.

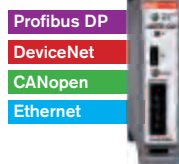

#### Bus connection

Pluto AS-i can be connected with other Pluto units both via the AS-i bus and through the Pluto safety bus.

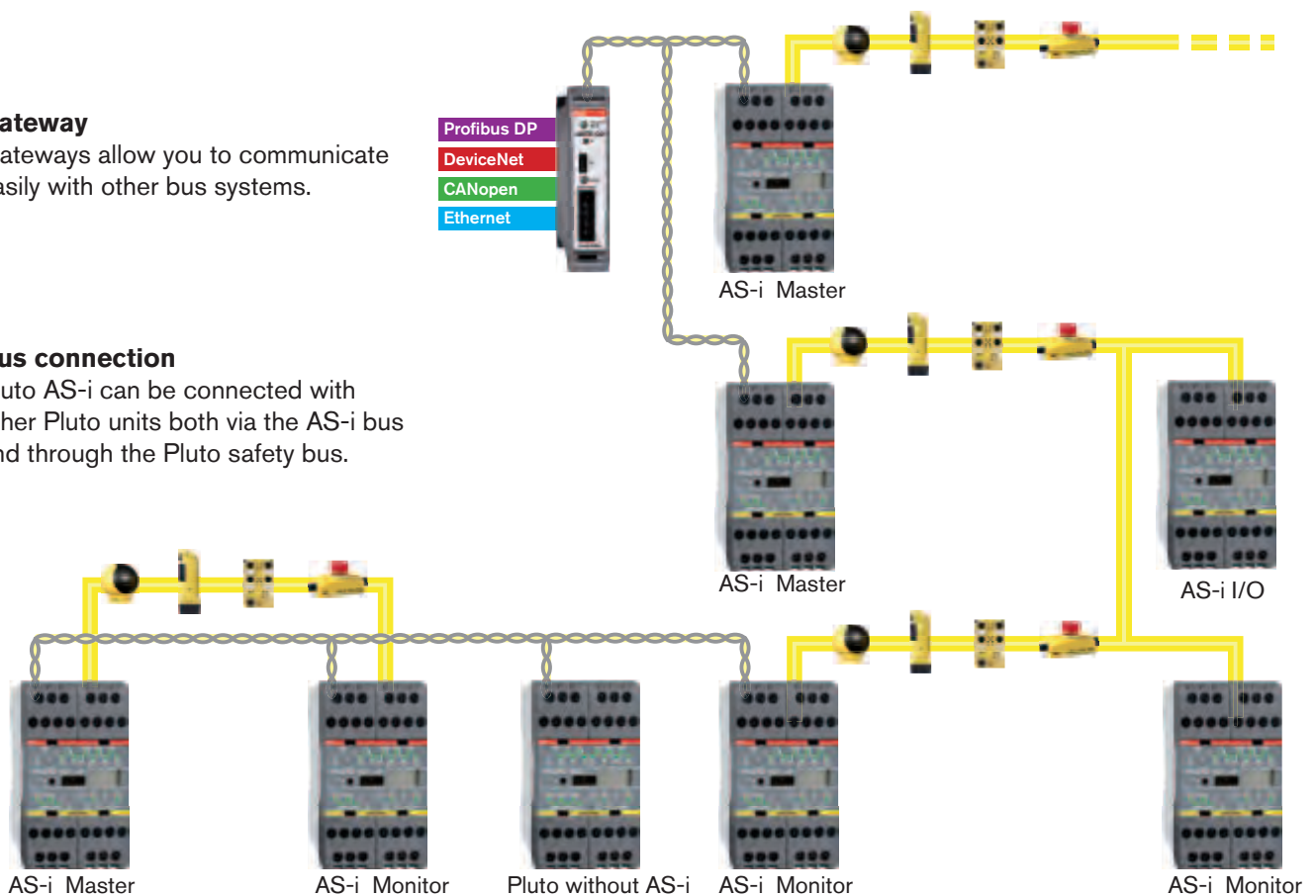

#### How large can you build the system?



From a technical aspect there are no constraints on the size of the system you can build. A Pluto PLC can, in addition to processing a complete AS-i bus, communicate with another Pluto either through a Pluto safety bus or through the AS-i bus.

Through Pluto's safety bus, each Pluto can be a party to the I/Os of others and a total of 32 Plutos can be linked in this way. If two Plutos are connected to each other via the AS-i bus, each Pluto can be connected to 31 other Plutos. Using Gateways the system can be expanded further to other bus systems for information exchange.

Technical data – general	
<b>Manufacturer:</b>	ABB AB/Jokab Safety, Sweden
<b>Colour:</b>	Grey
<b>Operating voltage:</b>	24VDC ±15 %
<b>Assembly:</b>	35 mm DIN busbar
<b>Electrical insulation:</b>	Category II according to IEC 61010-1
<b>Safety level:</b> EN 954-1 EN ISO 13849-1 EN 61508 EN 62061	Cat. 4 PL e/cat. 4 SIL 3 SIL 3
<b>PFH<sub>d</sub></b> Relay output Transistor output	2.00×10 <sup>-9</sup> 1.50×10 <sup>-9</sup>
<b>Failsafe inputs I &amp; IQ</b> Type:  Current at 24V Max surge	+24 V (for PNP sensors), IQ is also configurable as non-safe outputs 5.1 mA 27V continuous
<b>Failsafe transistor outputs Q</b> Output voltage: Tolerance for output voltage: Max current:	-24 VDC Supply voltage - 1.5 V at 800 mA 800 mA
<b>Failsafe relay outputs Q</b> Max voltage Max current	250 VAC 1.5 A
<b>Non-failsafe outputs IQ</b> Type:  Max current/output:	Transistor +24 V, PNP "open collector" is also configurable as failsafe inputs 800 mA
<b>Indicator</b> Input/output LED Display:	1 per I/O (green) 7-segments, two characters

\* Each address can have an A and B node each containing four inputs and four outputs. The number of slaves can thereby be increased to 62.

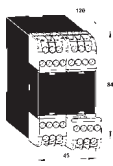
<b>Pluto-bus</b> Max number of Pluto on the bus: Bus type: Bus speeds:  Bus cable length:	32 CAN 100, 125, 200, 250, 400, 500, 800, 1,000 kb/s Up to 600 m 150 m at 400kb/s
<b>AS-i bus</b> Master profile: Number of slave units: Bus operation mode:  Bus cable length:	M2 31/62* Master Safety monitor Safety monitor, slave and safe I/O module. Up to 500 m 100 m between each repeater
<b>Temperature</b> Ambient temperature: Storage and transport:	-10°C - +50°C -25°C - +55°C
<b>Reaction times</b> Dyn.A or static input to relay output: Dyn.A or static input to transistor output:  Dyn.B or Dyn.C input to relay output: Dyn.B or Dyn.C input to transistor output: Setting "NoFilt":  AS-i bus to relay output: AS-i bus to transistor output:	<20.5 ms + prog. execution time <16.5 ms + prog. execution time  <23 ms + prog. execution time <19 ms + prog. execution time 5 ms shorter reaction time on I & IQ inputs <33 ms + prog. execution time <29 ms + prog. execution time
<b>Additional reaction times</b> Bus between Pluto units Bus between Pluto units following fault	10 ms 10–40 ms
<b>Enclosure protection class</b> Enclosure: Terminal blocks:	IP 40, IEC 60 529 IP 20, IEC 60 529

Technical data – type specific	 Pluto AS-i AS-i bus	 Pluto B42 AS-i AS-i bus
Part number/Ordering data:	2TLA020070R1 100	2TLA020070R1400
Failsafe inputs	4 ea (I0..I3)	20 ea (I0..I3, I30..I47)
Failsafe inputs or non-failsafe outputs	4 ea (IQ10..IQ13) Maximum total load 2A	16 ea (IQ10..IQ27) Maximum total load 2A
Analogue inputs	4 ea (IQ10..IQ13) 0..27V	3 ea (I1..I3) 0..27V
Failsafe relay outputs	2 ea (Q0..Q1)	4 ea (Q0..Q1 & Q4..Q5)
Failsafe transistor outputs	2 ea (Q2..Q3)	2 ea (Q2..Q3)
Current monitoring	–	–
Pluto-bus	▪	▪
AS-i bus	▪	▪
Internal current consumption	100 mA	150 mA
Recommended external fuse:	6A	10A
Dimensions (WxHxD)	45 x 84 x 118 mm	90 x 84 x 118 mm

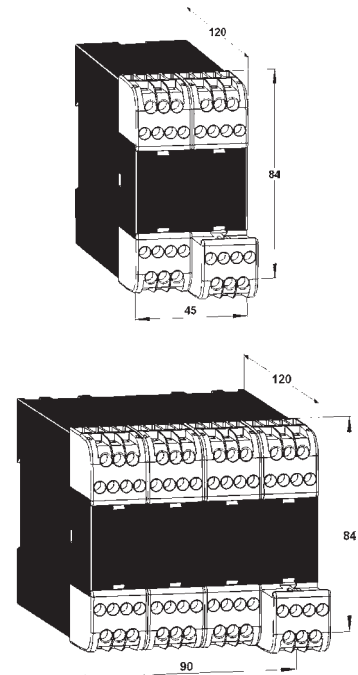

The connection block is removable having to disconnect any cables. The units are assembled with a gap of at least 5 mm.

## I/O - Pluto AS-i

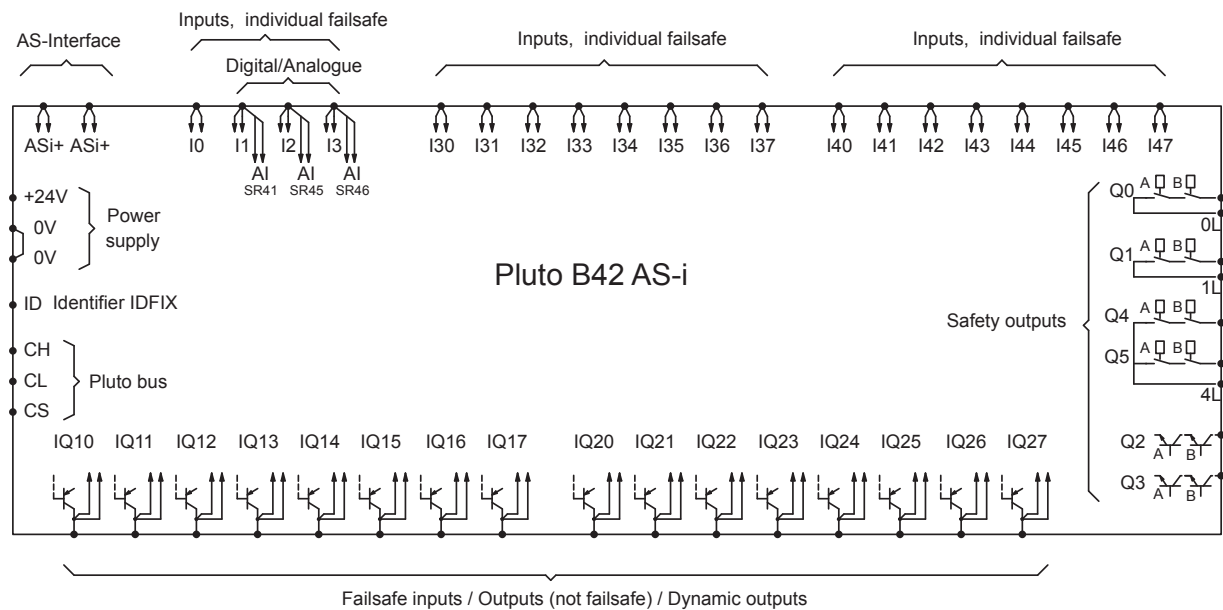
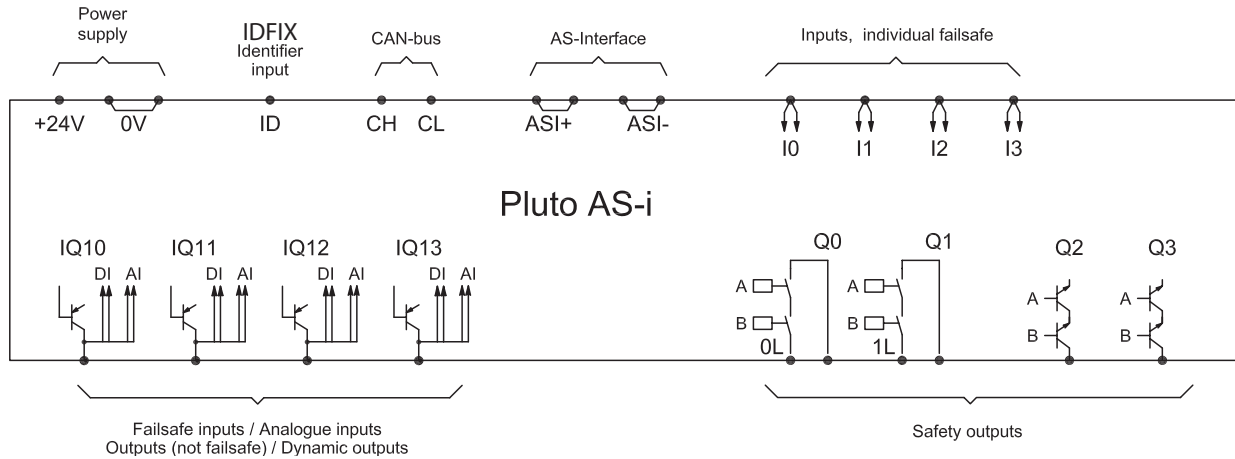

- ID: Connection for identifiers that have a unique ID number that can be read by the system.
- I.. Safety inputs (24 VDC) that are individually safe. This means that you can achieve the highest level of safety with only one input when you use ABB Jokab Safety's dynamic safety components. Otherwise, two inputs per safety function are required.
- IQ.. I/O that can be used as safety inputs or signal outputs, e.g. for indicating or controlling functions that are not safety related. For IQ .. as safety input see I..
- Q0, Q1: Failsafe relay outputs that are individually failsafe and independently programmable.
- Q2, Q3: Failsafe transistor outputs (-24 VDC) that are individually failsafe and independently programmable. Designed for electromechanical components such as contactors and valves.
- Q4, Q5 Failsafe relay outputs with a common potential that are individually failsafe and independently programmable.