

Serial data converters "ILPH range"

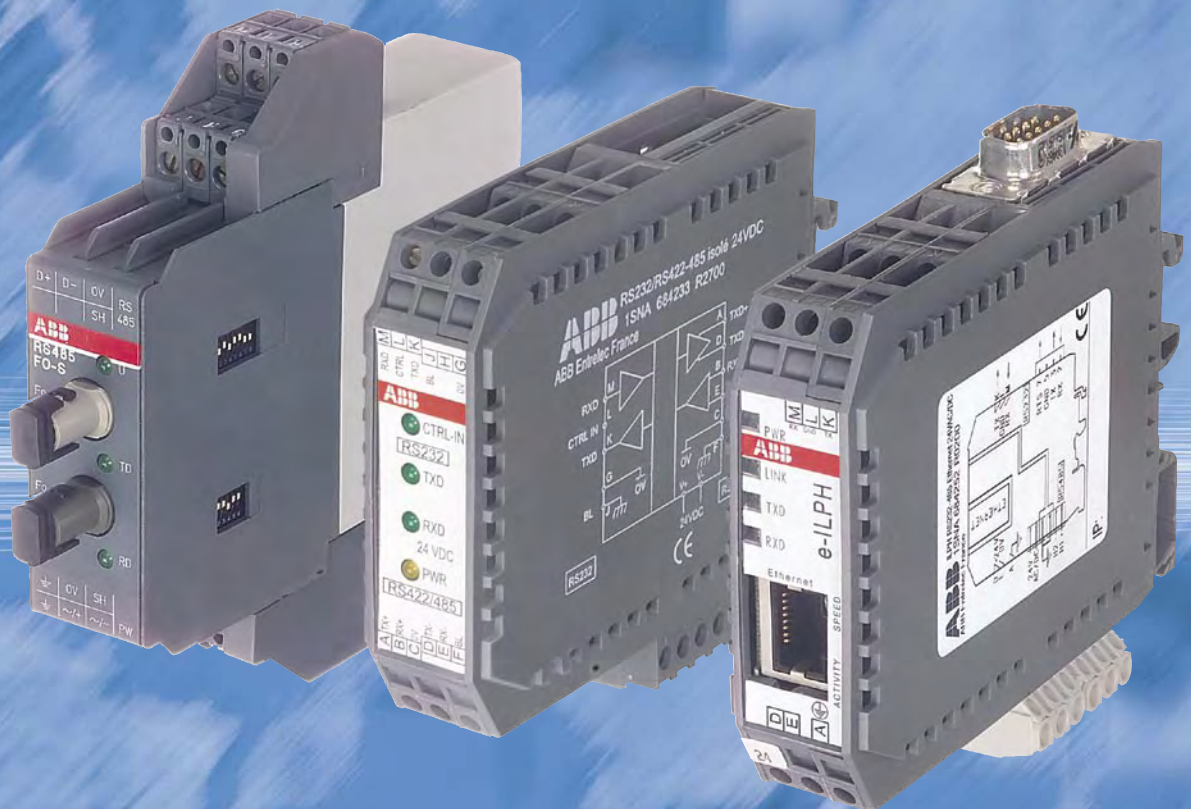

Serial data converters

In the field of industrial data transmission, various processes of data transmission and interfaces are used today. Already existing systems need to be updated or connected to new devices for continuity of process. When new communication functions are not build-in, ABB propose a range of converters to be able to use from the standard RS232 or RS485, to the Ethernet open products or the Optical Fiber.

Ethernet communication is now one of the main features need in open communication, ABB propose the e-ILPH to connect the serial devices to the web world.

Uses

Adaptation :

The use of converters allows the connection of two devices using different interfaces.

To add new equipment to existing installations.

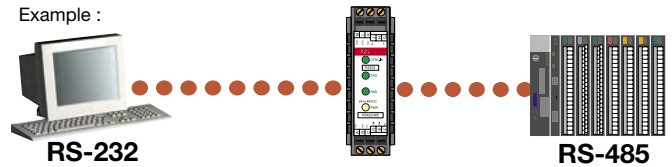

Galvanic Isolation :

To protect sensitive equipment it is sometimes necessary to use converters which allow galvanic isolation.

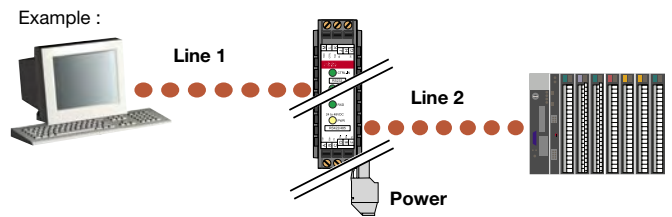

To cross a disturbed environment :

Some interfaces are more sensitive to noise. Electrically, it is preferable, in some cases, to change the interface or support.

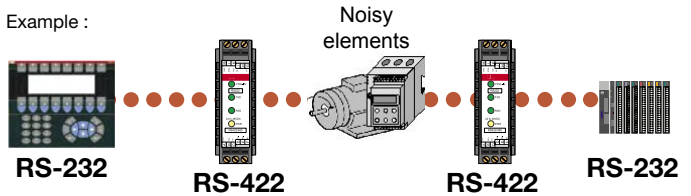

Type of connection	Immunity to noise
RS232	Low
RS422	High
RS485	High
CL	High
OF	Very high
Ethernet	High

Multipoint connections :

Some equipments are only designed to communicate in RS232 point to point connection. To communicate with several devices it is then necessary to use converters RS232 to RS422, RS485, CL or OF to reach multipoint mode.

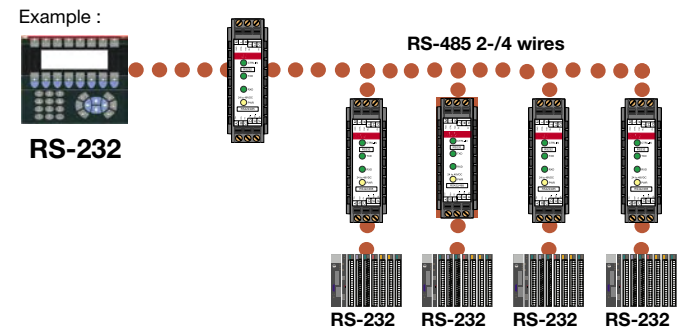

Type of connection	Connection
RS232	Point to point
RS422	12 points
RS485	32 points
CL	5-6 points
OF	32 points
Ethernet	Point to point or multipoint

Increase in the transmission and amplification distances of the signals :

Every connection has its own limits, to increase the communication distances you only have to change the type of link (converter) or amplify the signal (Repeater) using an ILPH.

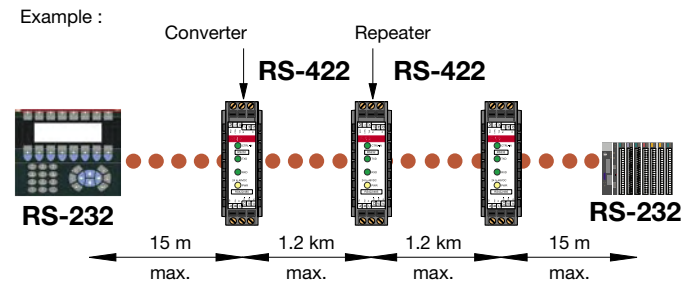

Type of connection	Max. distances *
RS232	15m
RS422	1.2km
RS485	1.2km
CL	300-500m
OF	4km
Ethernet	100 m with CAT5 cable

* Depending on transmission speed.

"World Wide" communication :

Communication is more and more used with Ethernet support. The interests are to have a distant access, to use an already existing network and to upload information and data on a supervisor or a computer. The conversions from serial to Ethernet protocol are used to connect local network to Ethernet.

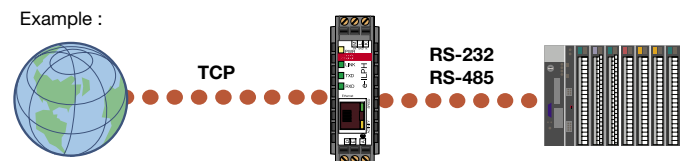

Protocol conversion :

Modbus is one of the main protocols used in the industrial networks. The creation of Modbus/TCP allows an adapted access to the Ethernet network. So, the conversion between these 2 protocols is necessary.

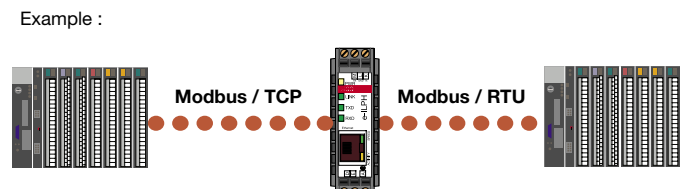

Product overview

	RS232	RS422 / RS485	CL	OF-S	OF-P	Ethernet	24 V DC	24-48 V DC	110-240 V AC	24-42 V AC/DC	10-34 VDC, 10-24 VAC	Insulation *	Part numbers
RS232	●							●				In-Ps-Out	1SNA 684 234 R2000
	●								●			In-Ps-Out	1SNA 684 244 R0200
		●					●					Wi	1SNA 684 231 R2500
		●					●					In-Out	1SNA 684 233 R2700
		●						●				In-Ps-Out	1SNA 684 333 R2300
		●							●			In-Ps-Out	1SNA 684 334 R2400
			●				●					In-Out	1SNA 684 202 R0100
				●					●			In-Ps-Out	1SNA 684 236 R2200
				●					●			In-Ps-Out	1SNA 684 237 R2300
					●				●			In-Ps-Out	1SNA 684 238 R0400
RS422 / RS485		●					●					In-Out	1SNA 684 212 R2200
			●				●					In-Out	1SNA 684 232 R2600
RS485				●					●			In-Ps-Out	1SNA 684 246 R0400
				●				●				In-Ps-Out	1SNA 684 247 R0500
					●				●			In-Ps-Out	1SNA 684 248 R1600
					●			●				In-Ps-Out	1SNA 684 249 R1700
RS232 / RS485					●				●		In-Ps-Out	1SNA 684 252 R0200	

* In=Input, Ps=Power supply, Out=Output, Wi=Without insulation

- **RS 232 - EIA-232 / V.24 / V.28**

Point-to-point connection
Max. 15 m transmission distance
Rate up to 19.2 kbit/s
Full-duplex

- **RS 422 - EIA-422 / V.11**

Point-to-point connection
(1 Transmitter - 10 Receivers)
Differential voltage transmission
Full-duplex
Up to 1200 m/ 10Mbit/s
Good EMC characteristics

- **Current loop(TTY)**

Point-to-point / multi-point connection
Active or passive current loop
Full-duplex
Up to 1200 m/19.2 kBit/s
Good EMC characteristics

- **RS 485 - ISO/IEC/EIA-485**

Multi-point connection up to 32 units
Differential voltage transmission
Half-duplex on 1 pair
Full-duplex on 2 pairs
Up to 1200 m / 10Mbit/s
Good EMC characteristics

- **Optical fiber interface**

Point-to-point connection
Full-duplex
From 40m up to 4km transmission distance
according to optical fiber material (plastic / glass)
and wavelength used up to 10 Mbit/s
Excellent EMC characteristics

- **Ethernet Interface**

Point to point connexion or multipoint connection.
Up to 100m using CAT5 cable without Hub or Switch
10/100 Mbit/s
Good EMC characteristics

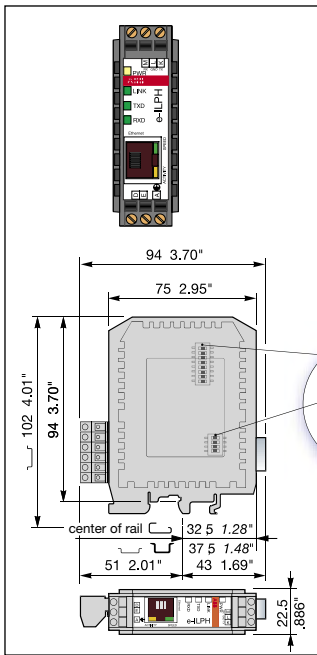

ILPH RS 232 - 485 / Ethernet

Isolated RS232 or/and RS485 to Ethernet converter

- Triple galvanic isolation
- RS232 on SUBD 9 points or screw connectors
- RS485 on removable screw connectors
- Ethernet 10/100 Mbit/s, RJ45 connector
- Power supply 10-34 VDC et 10-24 VAC
- Possible to have a redundant 10-34 VDC power supply
- Economic with low consumption
- Up to 100m with CAT5 cable without Hub or Switch
- Good EMC characteristics
- Up to 2 Modbus®/TCP Masters

Available modes:

- Modbus®/TCP to Modbus® RTU conversion
- Transparent Client or Server mode
- SMTP mode (Mail send)

Standards: TPC/IP, TELNET, DHCP, FTP

Specifics functions in Modbus® protocol:

- Concentrator (Asynchronous mode) up to 1200 words
- AC31 programming
- Modbus® Easy Net mode : this mode could be used to exchange data without a Modbus®/TCP master. The data are logged in a table and could be distributed to one or all the others e-ILPH participants on Ethernet.

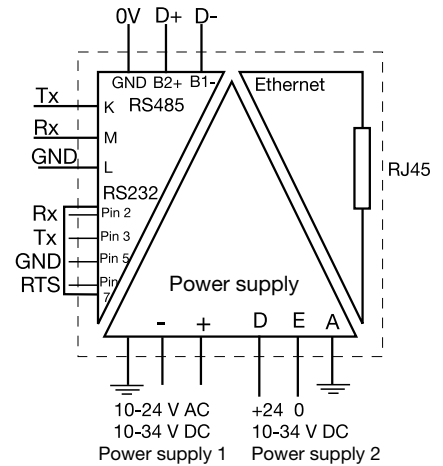

Description	Type	Order P/N	Packaging	Weight
Serial data converter e-ILPH	ILPH RS 232-RS 485 / Ethernet	1SNA 684 252 F0200	1	0,12 kg

Technical data

SubD9 connector pin 2 = RX pin 3 = TX pin 5 = GND pin 7 = RTS	
Power supply 1 Voltage: 10...34 V DC, 10...24 V AC Voltage tolerance: -10%, +10% Consumption: 2 W max Connections: coding screw removable connector 0 to 2,5 mm ² (22-14 AWG)	
Power supply 2 Voltage: 10...34 V DC Voltage tolerance: -10%, +10% Consumption: 2 W max Connections: screw connector (AWG 20)	
Serial link 1 : RS 232 Overvoltage protection: integrated Baud rate / Transmission distance: max. 115,2 kbits/s / max. 15 m Connections: 2,5 mm ² screw connector (AWG 20) or male SubD 9 points	
Serial link 2 : RS 485 Overvoltage protection: integrated Line polarization: integrated End line resistance: integrated Baud rate / Transmission distance: max. 115,2 kbits/s / max. 1200 m Connections: coding screw removable connector 0 to 2,5 mm ² (22-14 AWG)	
Ethernet link Overvoltage protection: integrated Baud rate / Transmission distance: 10-100 Mbits/s / max. 100 m without Hub or Switch with CAT5 cable Connections: RJ45 connector	
Traffic indication Voltage: 1 yellow LED Status of signal: 3 green LED (Rx, Tx, LINK), 2 amber or green LED (Speed, Activity)	
EMC behavior Electrostatic discharge: EN 61000-4-2 Radiated electromagnetic field: EN 61000-4-3 Burst: EN 61000-4-4 Surge: EN 61000-4-5 Electromagnetic compatibility: EN 55022	
Other characteristics Galvanic isolation between serial link / power supply / Ethernet link: 750 VDC / 1500 VAC Configuration of the operating mode: using internal switches or/and software (TELNET or HYPERTERMINAL) Operating temperature: 0°C ... +60°C Storage temperature: -20°C ... +70°C Mounting: any required DIN rail fixing (EN 50002): snap-on mounting Wire size: 2,5 mm ² / stranded with ferrule, 4 mm ² solid Dimensions (W x D x H): 94 x 22,5 x 100 mm Weight: 120 g	

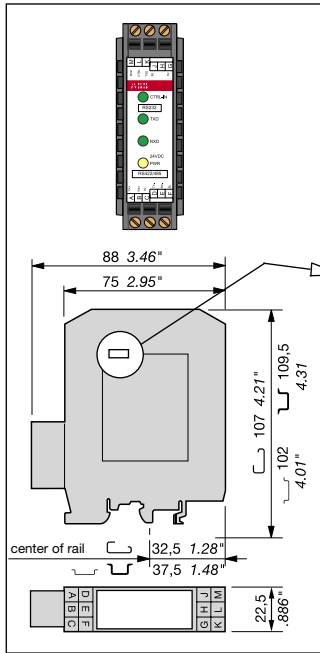

ILPH RS 232 / RS 422 - 485

RS 232 to RS 422-485 serial link without isolation

- Economic version without isolation
- Baudrate up to 38,4 kbit/s
- Transmission distance up to 1200 m
- RS 485 1 or 2 pair handling
- Usable in "noisy" environments
- 24 V DC power supply
- CE mark

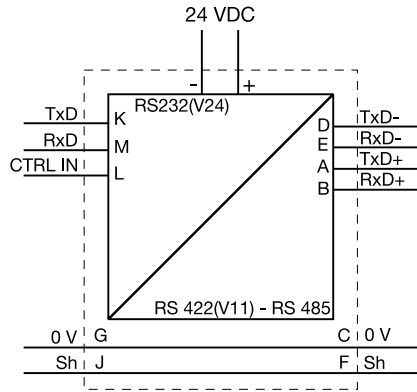
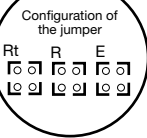

Description	Type	Order P/N	Packaging	Weight kg
Serial link interface without galvanic isolation	ILPH RS 232 / RS 422-485	1SNA 684 231 R2500	1	0,1

RS 485 LINK ON ONE PAIR

R		R ON/OFF	Jumper R in position	R ON/OFF
E		E ON/OFF	Jumper E in position	E ON/OFF

The Receiver and the Transmitter are activated alternately (never at the same time) depending on the status of the CTRL IN signal.

RS 422 LINK ON TWO PAIRS

R		R ON	Jumper R in position	R ON
E		E ON	Jumper E in position	E ON

The Transmitter and Receiver are both permanently active.

CTRL IN STATUS	ACTION ON RS 485
0 logic (+3V ≤ U ≤ +25V)	Transmitter active / Receiver inactive
1 logic (-25V ≤ U ≤ -3V)	Transmitter inactive / Receiver active
High impedance	Transmitter inactive / Receiver active

POLARIZATION OF THE RS 422 - RS 485 LINE

The line must always be polarized. The ILPH is used to polarize the reception channel:
 Connection by 1 wire P+ (J1.1) with 5V (J1.4)
 Connection by 1 wire P- (J1.2) with 0V (J1.3)

ADAPTING THE RS 422 - RS 485 LINE

The line must always be adapted to the level of the reception channel of each subscriber forming the end of the bus. The ILPH is used to adapt the reception channel by setting the jumper Rt correctly:

- Rt * Line adaptation, Rt = 120 Ω (general case)
- Rt * Line adaptation, Rt = 220 Ω
- Rt * No line adaptation, Rt = ∞

RS 422 - RS 485 SERIAL LINK (2 wires)

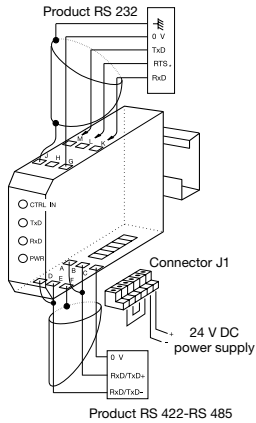

***CAUTION :**
When the RTS Signal is not activated, M terminal (RxD ILPH) has to be connected to L terminal (CTRL IN).

RS 422 - RS 485 SERIAL LINK (4 wires)

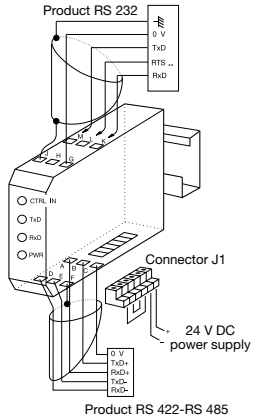

**** CAUTION :**
To be connected to 2 wired RS 485 only (not possible for 4 wired RS 422).
When the RTS Signal is not activated, M terminal (RxD ILPH) has to be connected to L terminal (CTRL IN).

RS 485 LINK ON 2 PAIRS

R		R ON	Jumper R in position	R ON
E		E ON/OFF	Jumper E in position	E ON/OFF

Receiver permanently active
 Transmitter controlled by the signal CTRL IN (see table for Transmitter operation as a function of CTRL IN)

Technical data

Power supply	polarized
Voltage	24 V DC
Voltage tolerance	8,5...28 V DC
Supply current	100 mA max
Connections	removable screw connectors (AWG 20)
RS 232-1 serial link	EIA RS 232 C / CCITT V24 V28
Overvoltage protection	integrated (transil 8 kV 1,2/50 μs)
Baud rate / Transmission distance	max. 38,4 kbits/s / max. 1200 m
Connections	2,5 mm ² screw connectors (AWG 20)
RS 422-485-2 serial link	EIA RS 485 and EIA RS 422 / CCITT V11
Overvoltage protection	integrated (transil 8 kV 1,2/50 μs)
Baud rate / Transmission distance	max. 38,4 kbits / max. 1200 m
Connections	2,5 mm ² screw connectors (AWG 20)
Traffic indication	
Voltage	1 yellow LED
Status of signal	2 green LED (RxD, TxD)
EMC behavior	
Electrostatic discharge	EN 61000-4-2 level 3 6/8 kV
Radiated electromagnetic field	EN 61000-4-3 level 310 V/m
Burst	EN 61000-4-4 level 3 1 kV
Electromagnetic compatibility	EN 55022 class B
Other characteristics	
Galvanic isolation between input / power supply / output	no
Configuration of the operating mode	using internal jumper
Operating temperature	0°C ... +50°C
Storage temperature	-25°C ... +80°C
Mounting	any required
DIN rail fixing (EN 50002)	snap-on mounting
Wire size	2,5 mm ² / stranded with ferrule, 4 mm ² solid
Dimensions (WxDxH)	88 x 22,5 x 100 mm
Weight	100 g



Serial data converters

"ILPH Range"

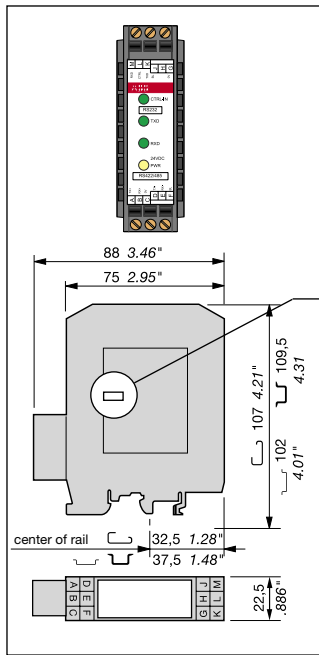

ILPH RS 232 / RS 422 - 485

- Galvanic isolated converter for RS 232 to RS 422-485 serial links.
- Galvanic isolation between input/output and output/power supply
- Baudrate up to 38,4 kbit/s
- Transmission distance up to 1200 m
- RS 485 1 or 2 pair handling
- Usable in "noisy" environments
- 24 V DC power supply
- CE mark

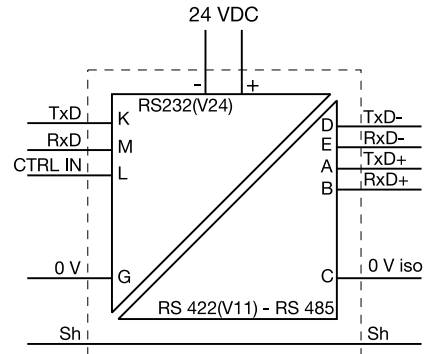

Description	Type	Order P/N	Packaging	Weight kg
Serial link interface with galvanic isolation	ILPH RS 232 / RS 422-485	1SNA 684 233 R2700	1	0,1

RS 485 LINK ON ONE PAIR

- R R ON/OFF Jumper R in position R ON/OFF
- E E ON/OFF Jumper E in position E ON/OFF

RS 422 LINK ON TWO PAIRS

- R R ON Jumper R in position R ON
- E E ON Jumper E in position E ON

The Receiver and the Transmitter are activated alternately (never at the same time) depending on the status of the CTRL IN signal.

The Transmitter and Receiver are both permanently active.

CTRL IN STATUS	ACTION ON RS 485
0 logic (+3V ≤ U ≤ +25V)	Transmitter active / Receiver inactive
1 logic (-25V ≤ U ≤ -3V)	Transmitter inactive / Receiver active
High impedance	Transmitter inactive / Receiver active

POLARIZATION OF THE RS 422 - RS 485 LINE

The line must always be polarized. The ILPH is used to polarize the reception channel :
 Connection by 1 wire P+ (J1.1) with 5V (J1.4)
 Connection by 1 wire P- (J1.2) with 0V (J1.3)

ADAPTING THE RS 422 - RS 485 LINE

The line must always be adapted to the level of the reception channel of each subscriber forming the end of the bus. The ILPH is used to adapt the reception channel by setting the jumper Rt correctly :

- Rt * Line adaptation, Rt = 120 Ω (general case)
- Rt * Line adaptation, Rt = 220 Ω
- Rt * No line adaptation, Rt = ∞

CAUTION : For RS 232 products running the RTS (REQUEST TO SEND) signal, connect RTS to CTRL IN. Otherwise, connect M (Rx/D ILPH) to L (CTRL IN).

RS 485 LINK ON 2 PAIRS

- R R ON Jumper R in position R ON
- E E ON/OFF Jumper E in position E ON/OFF

Receiver permanently active
 Transmitter controlled by the signal CTRL IN (see table for Transmitter operation as a function of CTRL IN)

Technical data

Power supply	polarized
Voltage	24 V DC
Voltage tolerance	8,5...28 V DC
Supply current	100 mA max
Connections	Removable screw connectors (Omniconnect)
RS 232-1 serial link	EIA RS 232 C / CCITT V24 V28
Overvoltage protection	integrated (transil 8 kV 1,2/50µs)
Baud rate / Transmission distance	max. 38,4 kbits/s / max. 15 m
Connections	2,5 mm ² screw connectors (AWG 20)
RS 422-RS485-2 serial link	EIA RS 485 and EIA RS 422 / CCITT V11
Overvoltage protection	integrated (transil 8 kV 1,2/50 µs)
Baud rate / Transmission distance	max. 38,4 kbits / max. 1200 m
Connections	2,5 mm ² screw connectors (AWG 20)
Traffic indication	
Voltage	1 yellow LED
Status of signal	3 green LED (Rx/D, Tx/D and CTRL-IN)
EMC behavior	
Electrostatic discharge	EN 61000-4-2 level 3 6/8 kV
Radiated electromagnetic field	EN 61000-4-3 level 310 V/m
Burst	EN 61000-4-4 level 3 1 kV
Electromagnetic compatibility	EN 55022 class B
Other characteristics	
Galvanic isolation between	
RS 232/RS 422-485 and RS 422-485/power supply	500 V DC
Configuration of the operating mode	using internal jumper
Operating temperature	0°C ... +50°C
Storage temperature	-25°C ... +80°C
Mounting	any required
DIN rail fixing (EN 50002)	snap-on mounting
Wire size	2,5 mm ² / stranded with ferrule, 4 mm ² solid
Dimensions (WxDxH)	88 x 22,5 x 100 mm
Weight	100 g

RS 422 - RS 485 2 WIRE SERIAL LINKS

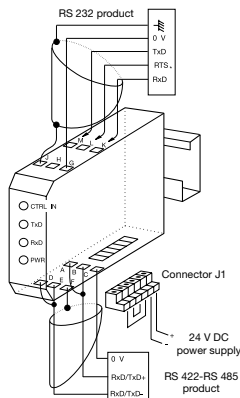

* CAUTION :
 If the RTS signal is not generated, connect M (Rx/D ILPH) to L (CTRL IN).

RS 422 - RS 485 4 WIRE SERIAL LINKS

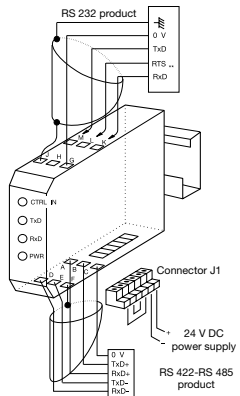

** CAUTION :
 Only to be connected for RS 485 two pairs (of no use for RS 422 two pairs). If the RTS signal is not generated, connect M (Rx/D ILPH) to L (CTRL IN).

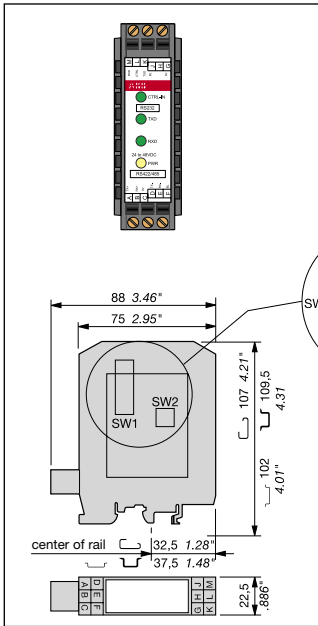

ILPH RS 232 / RS 422 - 485

- 3 way galvanic isolated converter for RS 232 to RS 422-485 serial links.
- 3 way galvanic isolation between power supply and input/output
- RS 485 switch on 2 or 4 wires
- Baudrate up to 38,4 kbit/s
- Transmission distance up to 1200 m
- RS 485 1 or 2 pair handling
- Usable in "noisy" environments
- 24...48 V DC and 115...230 V AC power supply
- CE marking

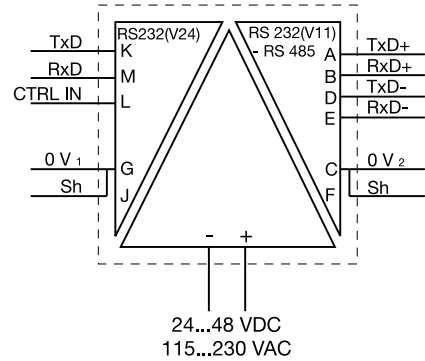

Description	Type	Order P/N	Packaging	Weight kg
Serial link interface	ILPH RS 232 / RS 422-485			
3 way galvanic isolation	24...48 V DC power supply	1SNA 684 333 P2300	1	0,1
	115...230 V AC power supply	1SNA 684 334 P2400	1	0,1

RS 422 - RS 485 2 WIRE SERIAL LINK

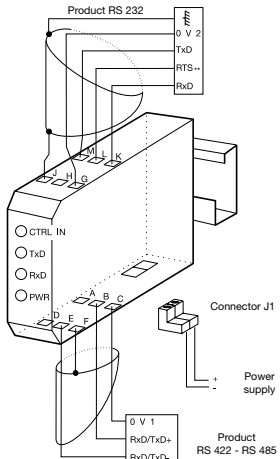

***CAUTION :**
When the RTS signal is not generated, set SW2-1 in position ON.

RS 422 - RS 485 4 WIRE SERIAL LINKS

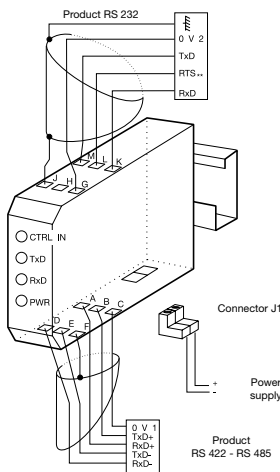

****CAUTION :**
Only to be connected for RS 485 two pairs (of no use for RS 422 two pairs). If the RTS signal is not generated, set SW2-1 in position ON.

RS 485 LINK ON ONE PAIR

Set SW1-1, SW1-3, SW1-6, SW1-7 and SW1-8 to position ON.
The receiver and the transmitter are activated alternately (never at the same time), depending on the status of the CTRL IN signal.

CTRL IN STATUS	Action on RS 485
0 Logic (3V ≤ U ≤ +25V)	Transmitter active / Receiver inactive
1 Logic (-25V ≤ U ≤ -3V)	Transmitter inactive / Receiver active
High impedance	Transmitter inactive / Receiver active

CAUTION : For RS 232 products running the RTS signal (REQUEST TO SEND), connect RTS to CTRL IN. Otherwise, set SW2-1 to position ON.

RS 485 LINK ON TWO PAIRS

Set SW1-1, SW1-3, SW1-7 in position OFF.
Set SW1-6, SW1-8 in position ON.
The receiver is permanently active.
The transmitter is controlled by the signal CTRL IN (see table for transmitter operation as a function of CTRL IN).

RS 422 LINK ON TWO PAIRS

Set SW1-1, SW1-3, SW1-7 and SW1-8 in position OFF.
Set SW1-6 in position ON.
Transmitter and receiver are both permanently active.

POLARIZATION OF THE RS 422 - RS 485 LINE

The line must always be polarized.
The ILPH is used to polarize the reception channel :
Set SW1-4 and SW1-5 in position ON.

ADAPTING THE RS 422 - RS 485 LINE

The line must always be adapted to the level of the reception channel of each subscriber forming the end of the bus.

The ILPH is used to adapt the reception channel by setting the jumper SW1-2 correctly :

SW1-2 in position ON ⇒ line adaptation, Rt = 120 Ω (standard)
SW1-2 in position OFF ⇒ no line adaptation, Rt = ∞

Power supply	Polarization for DC model	
Voltage	24...48 V DC	115...230 V AC (50/60 Hz)
Voltage tolerance	-15% ... +20%	-15% ... +15%
Supply current	24 V DC < 110 mA, 48 V DC < 55 mA, 115 V AC < 40 mA, 230 V DC < 26 mA	
Supply power	≈ 3 W	≈ 3 VA
Connections	Removable screw connector (Omniconnect)	
RS 232-1 serial link	EA / TIA RS 232 new revision / CCITT V24 V28	
Overvoltage protection	integrated (transil 8 kV 1,2/50 μs)	
Baud rate / Transmission distance	max. 38,4 kbits/s / max. 15 m / 2500 pF	
Connections	2,5 mm ² screw (AWG 20)	
RS 422/485-2 serial link	EIA RS 485 and EIA RS 422 CCITT V11	
Overvoltage protection	integrated (transil 8 kV 1,2/50 μs)	
Baud rate / Transmission distance	max. 38,4 kbits / max. 1200 m	
Connections	2,5 mm ² screw (AWG 20)	
Traffic indication		
Voltage	1 yellow LED	
Status of signal	3 green LED (Rx/D, Tx/D and CTRL-IN)	
EMC behavior		
Electrostatic discharge	EN 61000-4-2 level 3 6/8 kV	
Radiated electromagnetic field	EN 61000-4-3 level 310 V/m	
Burst	EN 61000-4-4 level 3 1 kV	
Electromagnetic compatibility	EN 55022 class B	
Other characteristics		
Galvanic isolation between	RS 232 / Power supply / RS 422-RS 485	
Configuration of the operating mode	1,5 kV using internal jumper	
Operating temperature	0°C ... +50°C	
Storage temperature	-25°C ... +80°C	
Mounting	any required	
DIN rail fixing (EN 50002)	snap-on mounting	
Wire size	2,5 mm ² / stranded with ferrule, 4 mm ² solid	
Dimensions (WxDxH)	88 x 22,5 x 100 mm	
Weight	100 g	

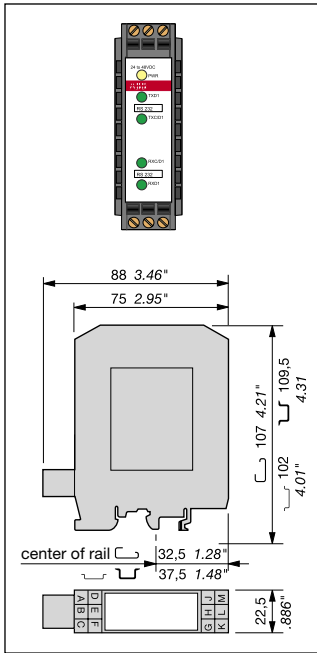

ILPH RS 232 / RS 232

3 way galvanic isolator between RS 232 serial interface and another RS 232 serial interface.

- Ensures triple insulation between the 2 serial interfaces and between each and power supply
- Baudrate up to 19,2 kbit/s (up to 64 kbit/s depending on cable)
- Transmission distance up to 15 m
- Can be used in "noisy" environments
- Power supply from 24...48 V DC and 115...230 V AC
- CE marking

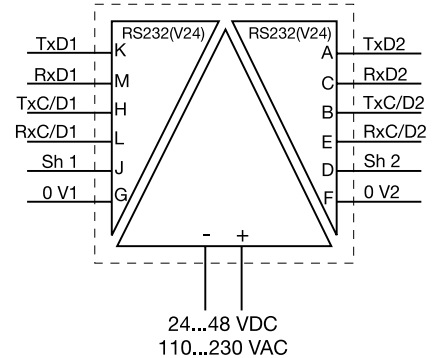

Description	Type	Order P/N	Packaging	Weight kg
Serial link interface	ILPH RS 232 / RS 232			
3 way galvanic isolation	24...48 V DC power supply	1SNA 684 234 F0200	1	0,1
	115...230 V DC power supply	1SNA 684 244 F0200	1	0,1

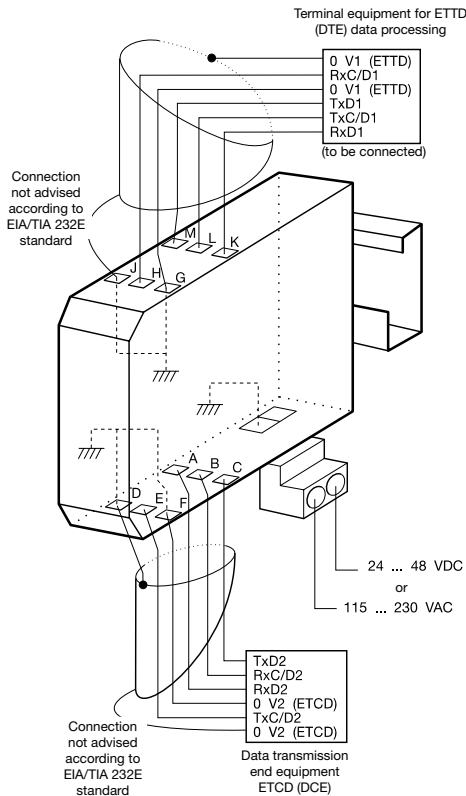

Technical data

Power supply	DC model polarized	
Voltage	24...48 V DC	115...230 V AC (50/60Hz)
Voltage tolerance	-15%...+20%	-15%...+15%
Supply current	24 V DC<155 mA;48 V DC<77 mA;110 V AC<40 mA;230 V DC<26 mA	
Supply power	≈ 3,15 W	≈ 3,15 VA
Connections	Removable screw connector (Omniconnect)	
RS 232-1 interface	EIA / TIA RS 232 new revision / CCITT V24 V28	
Overvoltage protection	integrated (transil 8 kV 1,2/50 μs)	
Transmission capacity /	max. 19,2 kbits/s / max. 15 m / 2500 pF	
Transmission distance		
Connections	2,5 mm ² screw (AWG 20)	
RS 232-2 interface	EIA / TIA RS 232 new revision / CCITT V24 V28	
Overvoltage protection	integrated (transil 8 kV 1,2/50μs)	
Transmission capacity /	max. 19,2 kbits/s / max. 15 m	
Transmission distance		
Connections	2,5 mm ² screw (AWG 20)	
Traffic indication		
Voltage	1 yellow LED	
Status of signal	4 green LED (Rx/D, Rx/C/D, Tx/D, Tx/C/D)	
EMC behavior		
Electrostatic discharge	EN 61000-4-2 level 3 6/8 kV	
Radiated electromagnetic field	EN 61000-4-3 level 3 10 V/m	
Burst	EN 61000-4-4 level 3 1 kV	
Electromagnetic compatibility	EN 55022 class B	
Other characteristics		
Galvanic isolation between input / power supply / output	1,5 kV	
Configuration of the operating mode	No	
Operating temperature	0°C ... +50°C	
Storage temperature	-25°C ... +80°C	
Mounting	any required	
DIN rail fixing (EN 50002)	snap-on mounting	
Wire size	2,5 mm ² / stranded with ferrule, 4 mm ² solid	
Dimensions (WxDxH)	88 x 22,5 x 100 mm	
Weight	100 g	



Serial data converters

"ILPH Range"

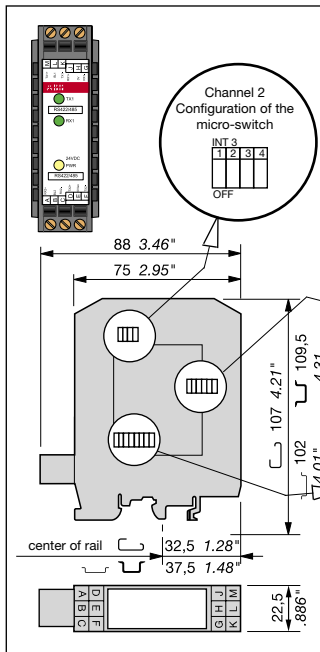

ILPH RS 422 - 485 / RS 422 - 485

Galvanic isolated connection between an RS 422-485 (1 or 2 pairs) and an RS 422 485 (1 or 2 pairs) serial link. It amplifies the signal beyond the 1200 m limit distance of the RS 422-485 and only needs a minimum of 1,5 character delay time to switch off the RS 485 drivers.

- Galvanic isolation between power supply/output and input/output
- Baudrate up to 500 kbit/s (up to 200 m)
- Transmission distance up to 1200m at 38,4 kbit/s
- Usable in "noisy" environments
- 2/4 wires automatic handling
- 24 V DC power supply
- CE mark

BAUD RATE	INT 1	INT 2	INT 3	INT 4
FULL DUPLEX	0 0 0 0	0 0 0 0	X X X 1	X X X 1 0 1
500 Kb/s	1 1 1 1	1 1 1 1	X X X 0	X X X 0 0 0
187,5 Kb/s	1 1 1 1	1 1 1 0	X X X 0	X X X 0 0 0
93,75 Kb/s	1 1 1 1	1 1 0 0	X X X 0	X X X 0 0 0
38,4 Kb/s	1 1 1 1	1 0 0 0	X X X 0	X X X 0 0 0
19,2 Kb/s	1 1 1 1	0 0 0 0	X X X 0	X X X 0 0 0
9,6 Kb/s	1 1 1 0	0 0 0 0	X X X 0	X X X 0 0 0
4,8 Kb/s	1 1 0 0	0 0 0 0	X X X 0	X X X 0 0 0
2,4 Kb/s	1 0 0 0	0 0 0 0	X X X 0	X X X 0 0 0
1,2 Kb/s	0 0 0 0	0 0 0 0	X X X 0	X X X 0 0 0

N_U = not used 1 = contact closed
 X = zero 0 = contact open (aus) (off)

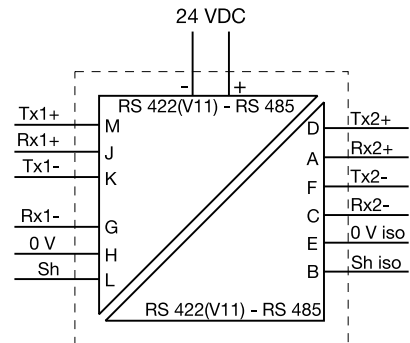

Description	Type	Order P/N	Packaging	Weight kg
Serial link interface with galvanic isolation	ILPH RS 422 - 485 / RS 422 - 485 24 V DC power supply	1SNA 684 212 R2200	1	0,1

RS 422 - RS 485 2 wire serial link

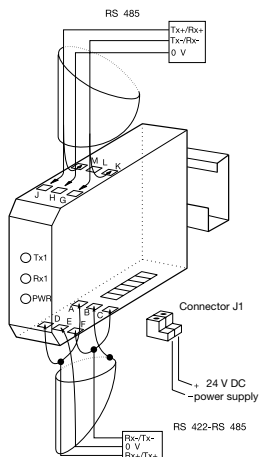

RS 422 - RS 485 DRIVERS CONTROL

The RS 422 - RS 485 Drivers Control (transmitters and receivers) makes the ILPH easy to use. The control of the 2 channels is completely automatic ; you only have to configure the baud rate needed.

The minimum turn off delay is about 1,5 character/time from 27 µs to 10 ms depending on the baud rate selected.

POLARIZATION OF THE RS 422 - RS 485 CONNECTIONS

The connections must always be polarized. The ILPH is used to polarize the reception channels :

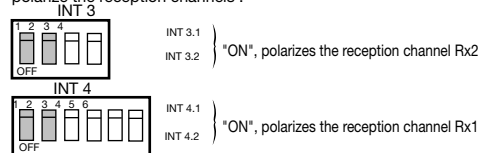

ADAPTING THE RS 422 - RS 485 CONNECTIONS

The connections must always be adjusted to the level of the reception channel of each subscriber forming the end of the bus. The ILPH is used to adjust the reception channel by setting the micro-switch INT 3.3 and INT 4.3.

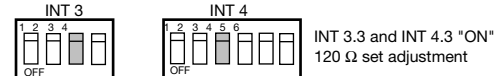

BAUD RATE

By using the 8 micro-switches inside the box.

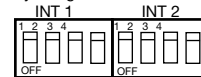

Permits to define up to 8 transmission speeds and to select the Full Duplex operation mode (RS 422 / RS 422) in addition with the INT 3.4 INT 4.4 and INT 4.5 micro switches.

RS 422 - RS 485 4 wire serial link

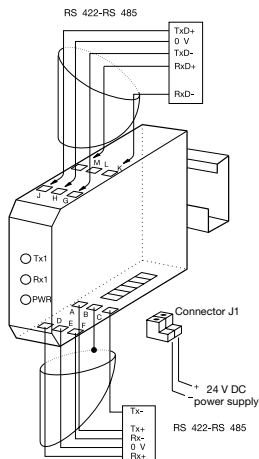

Technical data

Power supply	DC model polarized
Voltage	24 V DC
Voltage tolerance	+/-15%
Supply current	120 mA max.
Connections	Removable screw connector (Omniconnect)
RS 422-485-1 interface	EIA / RS 485 and EIA RS 422 / CCITT V11
Overvoltage protection	integrated (transil 8 kV 1,2/50 µs)
RS 485 data switching	Time switching / Time delay transmission/reception 27 µs ... 10 ms
Baudrate / Transmission distance	from 1,2 to 500 kbits/s / max. 1200 m up to 38,4 kbit/s
Connections	2,5 mm ² screw (AWG 20)
RS 422-485-2 interface	EIA / RS 485 and EIA RS 422 / CCITT V11
Overvoltage protection	integrated (transil 8 kV 1,2/50 µs)
RS 485 data switching	Time switching / Time delay transmission/reception 27 µs ... 10 ms
Baudrate / Transmission distance	from 1,2 to 500 kbits/s / max. 1200 m up to 38,4 kbit/s
Connections	2,5 mm ² screw (AWG 20)
Traffic indication	
Voltage	1 yellow LED
Status of signal	2 green LED (Rx _D , Tx _D)
EMC behavior	
Electrostatic discharge	EN 61000-4-2 level 3 6/8 kV
Radiated electromagnetic field	EN 61000-4-3 level 3 10 V/m
Burst	EN 61000-4-4 level 3 1 kV
Electromagnetic compatibility	EN 55022 class B
Other characteristics	
Galvanic isolation between input / power supply / output	500 V DC
Configuration of the operating mode	using internal DIP switches
Operating temperature	0°C ... +50°C
Storage temperature	-25°C ... +80°C
Mounting	any required
DIN rail fixing (EN 50002)	snap-on mounting
Wire size	2,5 mm ² / stranded with ferrule, 4 mm ² solid
Dimensions (WxDxH)	88 x 22,5 x 100 mm
Weight	100 g

Caution :

The transmission channels of both RS 422 - RS 485 serial link interfaces always have to be independently polarized.

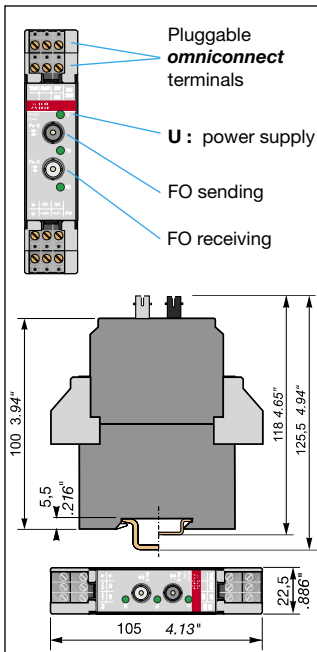

ILPH RS 232 / FO

- 3 way galvanic isolated Converter for RS 232 to optical fiber serial link glass (S) or plastic (P).
- 3 way galvanic isolation between power supply and input/output
- Baud rate up to 115,2 kbit/s
- Available for glass or plastic fiber
- Transmission distance up to 4 km
- Usable in "very noisy" environments
- 20...42 V AC/DC and 110...240 V AC/DC power supply
- CE marked

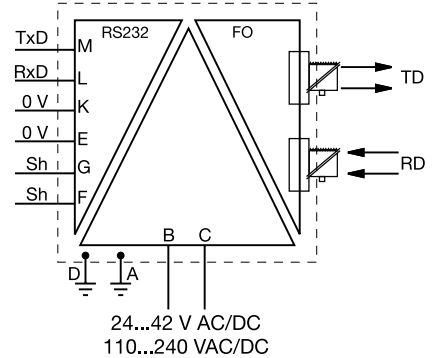

Description	Type	Order P/N	Packaging	Weight kg
Serial link interface	ILPH RS 232 / FO-S			
3 way galvanic isolation	24...42 V AC/DC Power supply	1SNA 684 236 F2200	1	0,15
	110...240 V AC/DC Power supply	1SNA 684 237 F2300	1	0,15
Serial link interface	ILPH RS 232 / FO-P			
3 way galvanic isolation	24...42 V AC/DC Power supply	1SNA 684 238 F0400	1	0,15
	110...240 V AC/DC Power supply	1SNA 684 239 F0500	1	0,15

RS 232 / FO

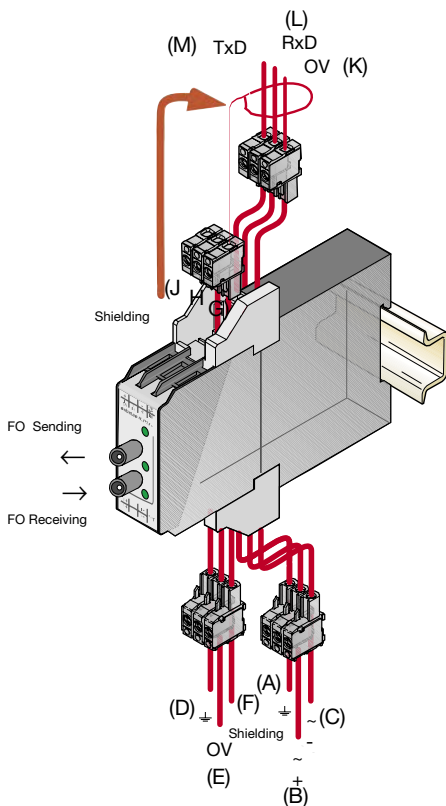

Technical data

Power supplies		24...42 V AC/DC (50/60 Hz)	110...240 V AC/DC (50/60 Hz)
Supply voltage		-15% ... +10%	-15% ... +10%
Voltage tolerance		Omniconnect pluggable connector	
Connections			
RS 232 Interface 1		CCITT V.24/DIN 66020- CCITT V.28 DIN 66259-EIA 232 E	
Protection		Integrated (transil 8 kV 1.2/50µs)	
Max. speed / Max. distance		Max. 115.2 kbits/s / max. 15 m / 2500 pF	
Connections		Omniconnect pluggable connector	
Fiber optic interface 2		DIN VDE 0888-1	
Type of fiber / Connections		Multimode fiber	
		Glass : ST connector	
		Plastic : FSMA screw connector	
Wavelength		Glass : 820 nm	
		Plastic : 655 nm	
Max. transmission power		Glass : 50/125 µm : -14.4 db/m	
		Glass : 62.5/125 µm : -14 db/m	
		Plastic : 980/1000 µm : -8 db/m	
Max. reception power		Glass : -28 db/m	
		Plastic : -20 db/m	
Max. speed		Max. 115.2 kbits/s	
Max. distance		Glass : 50/125 µm : 3 km	
		Glass : 62.5/125 µm : 4 km	
		Plastic : 980/1000 µm : 40 m	
Status indication		1 green LED / 2 green LEDs (Rx/D, Tx/D)	
Power supply / Data exchange			
EMC behavior			
Electrostatic discharge		EN 61000-4-2 Level 3 6/8 kV	
Radiated electromagnetic field		EN 61000-4-3 Level 3 10 V/m	
Burst		EN 61000-4-4 Level 3 1 kV	
Electromagnetic compatibility		EN 55022 Class B	
Other characteristics			
Galvanic isolation input / power supply / output		2.5 kV	
Operating temperature		-20°C ... +60°C	
Storage temperature		-40°C ... +85°C	
Mounting		Onto DIN Rail (EN 50002)	
Connections		14 AWG (2.5 mm ²) fine stranded / 12 AWG (4 mm ²) rigid	
Dimensions (WxDxH)		105 x 22.5 x 112 mm / 4.13 x 0.89 x 4.41"	
Weight		150 g / 0.33 lb	

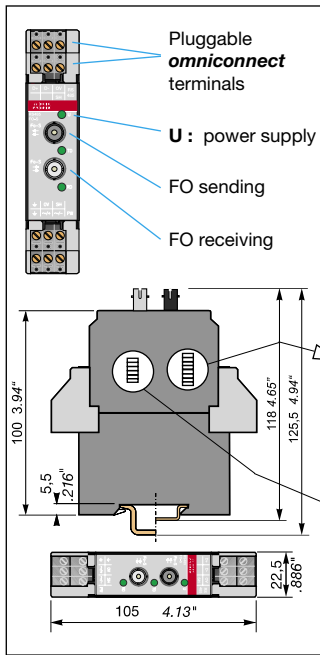

ILPH RS 485 / FO

- 3 way galvanic isolated converter for RS 485 (1 pair) to optical fiber serial link glass (S) or plastic (P).
- 3 way galvanic isolation between power supply and input/output
- Baud rate up to 1.5 Mbit/s
- Available for glass fiber or plastic fiber
- Transmission distance up to 4 km
- Usable in "very noisy" environments
- 20...42 V AC/DC and 110...240 V AC/DC power supply
- CE marked

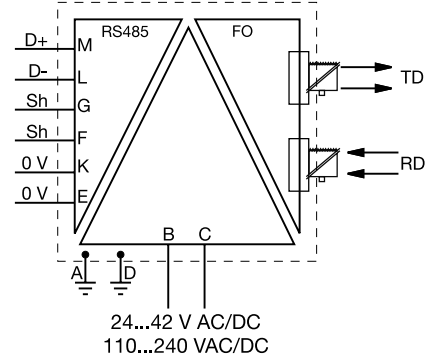

Baud rate :
SW1 DIP switch configuration

Baudrate bit/s	SW 1							
	1	2	3	4	5	6	7	8
1500000								
500000								
375000								
187500								
136000								
115200								
93750								
75000								
57600								
38400								
19200								
9600								
4800								
300								

Legend
 on
 off

End-of-line resistor, polarization
SW2 DIP switch configuration

	SW 2					
	1	2	3	4	5	6
Polarization						
EOL 60 ohm						
EOL 120 ohm						
EOL 180 ohm						
EOL 240 ohm						
EOL indefinite						

Description	Type	Order P/N	Packaging	Weight kg
Serial link interface 3 way galvanic isolation	ILPH RS 485 / FO-S			
	24...42V AC/DC Power supply	1SNA 684 246 R0400	1	0,15
	110...240 V AC/DC Power supply	1SNA 684 247 R0500	1	0,15
Serial link interface 3 way galvanic isolation	ILPH RS 485 / FO-P			
	24...42V AC/DC Power supply	1SNA 684 248 R1600	1	0,15
	110...240 V AC/DC Power supply	1SNA 684 249 R1700	1	0,15

RS 485 / FO

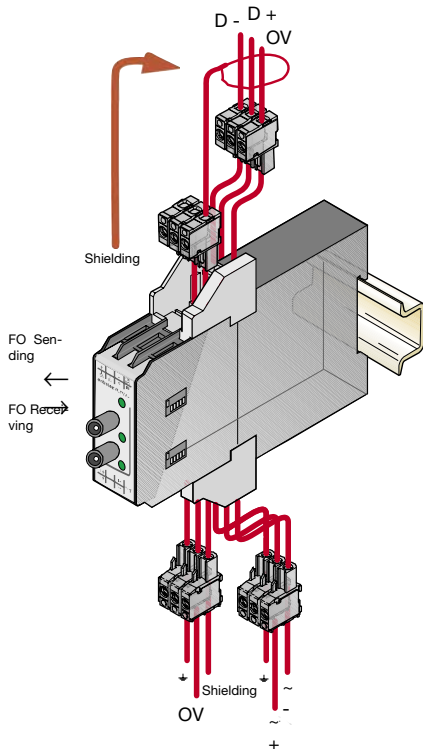

Technical data

Power supplies	
Supply voltage	24...42 V AC/DC (50/60 Hz) 110...240 V AC/DC (50/60 Hz)
Voltage tolerance	-15% ... +10% -15% ... +10%
Connections	Omniconnect pluggable connector
RS 485 interface 1	ISO / IEC 8482 / DIN 66 259-4; EIA 485
Protection	Integrated (8 kV 1.2/50µs)
Max. speed / max. distance	Max. 1.5 Mbits/s / max. 1200 m (38.4 kbit/s)
Connections	Omniconnect Pluggable connector
Optic fiber interface 2	DIN VDE 0888-1
Type of fiber / Connections	Multimode fiber Glass : ST connector Plastic : FSMA screw connector
Wavelength	Glass : 820 nm Plastic : 655 nm
Max. transmission power	Glass : 50/125 µm : -14.4 db/m Glass : 62.5/125 µm : -14 db/m Plastic 980/1000 µm : -8 db/m
Max. reception power	Glass : -28 db/m Plastic : -20 db/m
Max. speed	Max. 1.5 Mbit/s
Max. distance	Glass : 50/125 µm : 3 km Glass : 62.5/125 µm : 4 km Plastic 980/1000 µm : 40 m
Status indication	
Power supply / Data exchange	1 green LED / 2 green LEDs (Rx/D, Tx/D)
EMC behavior	
Electrostatic discharge	EN 61000-4-2 Level 3 6/8 kV
Radiated electromagnetic field	EN 61000-4-3 Level 3 10 V/m
Burst	EN 61000-4-4 Level 3 1 kV
Electromagnetic compatibility	EN 55022 Class B
Other characteristics	
Galvanic isolation input / power supply / output	2.5 kV
Function configuration	With DIP-Switches
Operating temperature	-20°C ... +60°C
Storage temperature	-40°C ... +85°C
Mounting	Onto DIN Rail
Connections	14 AWG (2,5mm ²) / fine stranded, 12 AWG (4 mm ²) rigid
Dimensions (WxDxH)	105 x 22.5 x 112 mm / 4.13 x 0.89 x 4.41"
Weight	150 g / 0.33lb



Serial data converters

"ILPH Range"

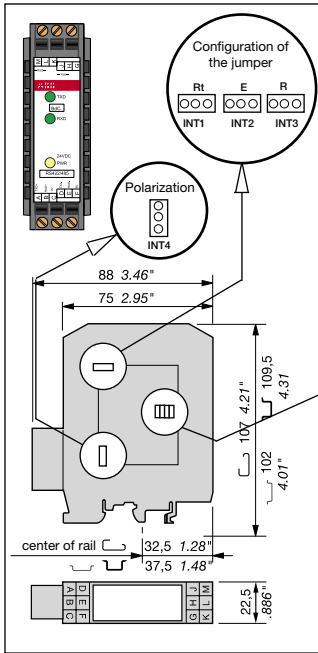

ILPH CL / RS 422 - 485

- Galvanic isolated converter for current loop to RS 422-485 (1 or 2 pairs) serial link.
- Galvanic isolation between power supply/current loop and RS 422-485/current loop
- Active/passive 0...20 mA / 4...20 mA selectable
- Positive or negative logic selectable
- Baudrate up to 38,4 kbit/s (up to 2400 m)
- Transmission distance up to 2400 m (1200 m RS 485 and 1200 m current loop)
- Usable in "noisy" environments
- 24 V DC power supply
- CE marking

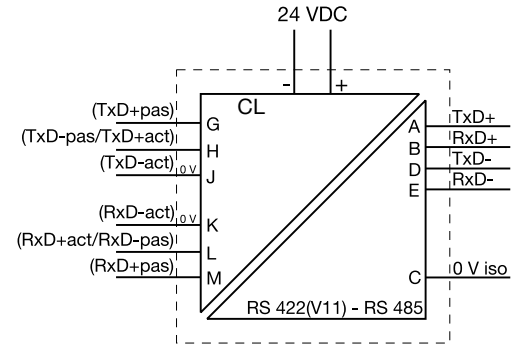

RS 422 - RS 485 2 wire serial link

CONNECTIONS

Example of connection with a CL (current Loop) product, Transmission (TxD) in active mode and Reception (RxD) in passive mode. Then, the ILPH must be configured and connected Reception (RxD) in passive mode and Transmission (TxD) in active mode.

Note : For any other configuration, see schematic diagram or front sticker of the product.

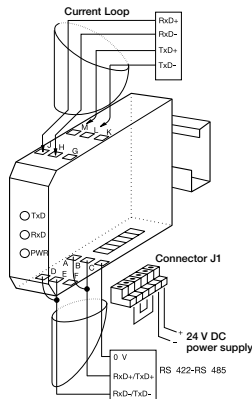

RS 422 - RS 485 4 wire serial link

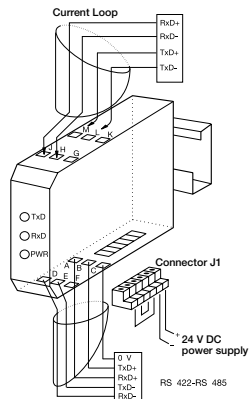

Note : The TxD channel of the RS 422 - RS 485 link must be polarized independently too.

Description	Type	Order P/N	Packaging	Weight kg
Serial link interface with galvanic isolation	ILPH BdC / RS 422 - 485 24 V DC power supply	1SNA 684 232 F2600	1	0,1

LINE AMPLIFIER CONFIGURATION

Configuration of amplifiers of the RS 422 - RS 485 (Receiver, Transmitter) line provides greater flexibility of use. The various configurations can be selected using the 2 jumpers (R INT2, E INT1) located inside the box.

RS 485 LINK ON ONE PAIR

- R INT2 R ON/OFF Jumper R in position R ON/OFF
- E INT3 E ON/OFF Jumper E in position E ON/OFF

The Receiver and the Transmitter are activated alternately (never at the same time) depending on the status of the Current Loop Reception signal.

RS 485 LINK ON TWO PAIRS

- R INT2 R ON Jumper R in position R ON
- E INT3 E ON/OFF Jumper E in position E ON/OFF

Receiver permanently active. Transmitter controlled by the Current Loop Reception signal.

RS 422 LINK ON TWO PAIRS

- R INT2 R ON Jumper R in position R ON
- E INT3 E ON Jumper E in position E ON

The Receiver and the Transmitter are both permanently active.

POLARIZATION OF THE RS 422 - RS 485 LINE

The line must always be polarized. The ILPH is used to polarize the reception channel :

Connection by 1 wire P+ (J1.1) with 5 Viso (J1.4)
Connection by 1 wire P- (J1.2) with 0 Viso (J1.3)

ADAPTING THE RS 422 - RS 485 LINE

The line must always be adapted to the level of the reception channel of each subscriber forming the end of the bus. The ILPH is used to adapt the reception channel by setting the jumper Rt correctly :

- Rt INT1 * Line adaptation, Rt = 120 Ω (Standard)
- Rt INT1 * No line adaptation, Rt = ∞

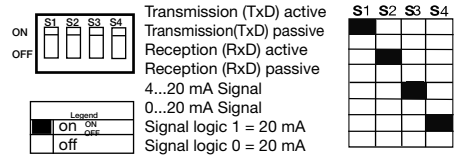

POLARIZATION

The polarization can be configured using the INT4 jumper.

- INT4 Protection ON
- INT4 Protection OFF, used if power supply at minimum value (21,6 V).

Technical data

Power supply	DC model polarized
Voltage	24 V DC
Voltage tolerance	+/-10%
Supply current	120 mA max.
Connections	Removable screw connector (Omnicontact)
CL interface (Current Loop 1)	active/passive 0...20 mA / 4...20 mA, mode is settable
Logic level	0 = 20 mA or 1 = 20 mA, settable
Baud rate / Transmission distance	max. 38,4 kbit/s / max. 1200 m
Connections	2,5 mm ² screw (AWG 20)
RS 422/485-2 serial link	EIA RS 485 and EIA RS 422 / CCITT V 11
Overvoltage protection	integrated (transil 8 kV 1,2/50 μs)
Baud rate / Transmission distance	max. 38,4 kbit/s / max. 1200 m
Connections	2,5 mm ² screw (AWG 20)
Traffic indication	
Voltage	1 yellow LED
Status of signal	2 green LED (RxD, TxD)
EMC behavior	
Electrostatic discharge	EN 61000-4-2 level 3 6/8 kV
Radiated electromagnetic field	EN 61000-4-3 level 3 10 V/m
Burst	EN 61000-4-4 level 3 1 kV
Electromagnetic compatibility	EN 55022 class B
Other characteristics	
Galvanic isolation between input / output and power supply / output	depending on Current Loop (active/passive) 500 V DC (active) / 2000 V DC (passive)
RS 422-485 power supply	500 V DC
Configuration of the operating mode	using internal DIP switches
Operating temperature	0°C ... +50°C
Storage temperature	-25°C ... +80°C
Mounting	any required
DIN rail fixing (EN 50002)	snap-on mounting
Wire size	2,5 mm ² / stranded with ferrule, 4 mm ² solid
Dimensions (WxDxH)	88 x 22,5 x 100 mm
Weight	100 g

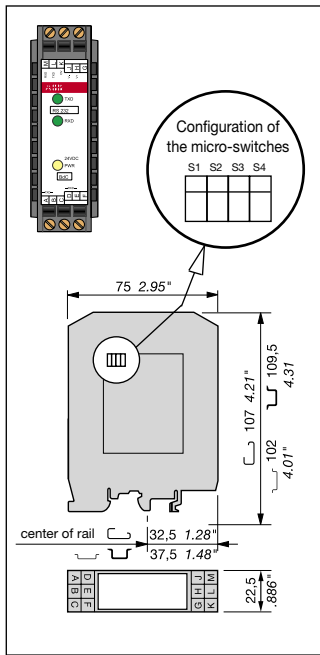

ILPH RS 232 / CL

Galvanic isolated Converter for RS 232 to current loop serial link.

- Galvanic isolation between power supply/current loop and RS 232/current loop
- Active/Passive 0...20 mA / 4...20 mA selectable
- Positive or negative logic selectable
- Baudrate up to 38,4 kbit/s
- Transmission distance up to 1200 m
- Usable in "noisy" environments
- 24 V DC power supply
- CE marking

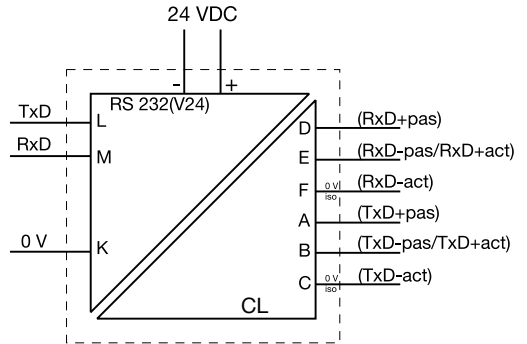

Description	Type	Order P/N	Packaging	Weight kg
Serial link interface with galvanic isolation	ILPH RS 232 / BdC 24 V DC power supply	1SNA 684 202 R0100	1	0,1

CONFIGURATION

The various configurations can be selected using the 4 micro-switches located inside the box.

OPERATING MODE ACTIVE OR PASSIVE

The Current Loop's Transmission and Reception can be independently in active or passive mode.

Select operating mode using **S1** and **S2**.

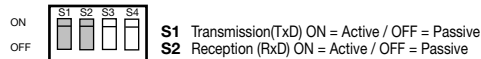

SIGNAL LEVEL

Select signal level 4-20 mA or 0-20 mA. This selection is made using micro-switch S3

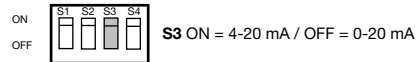

Caution :

It is not possible to select a 4-20 mA signal when the Reception is in active mode.

LOGIC LEVEL

Configuration : Positive logic (0 Logic = 20 mA) or negative logic (1 Logic = 20 mA)

using micro-switch S4

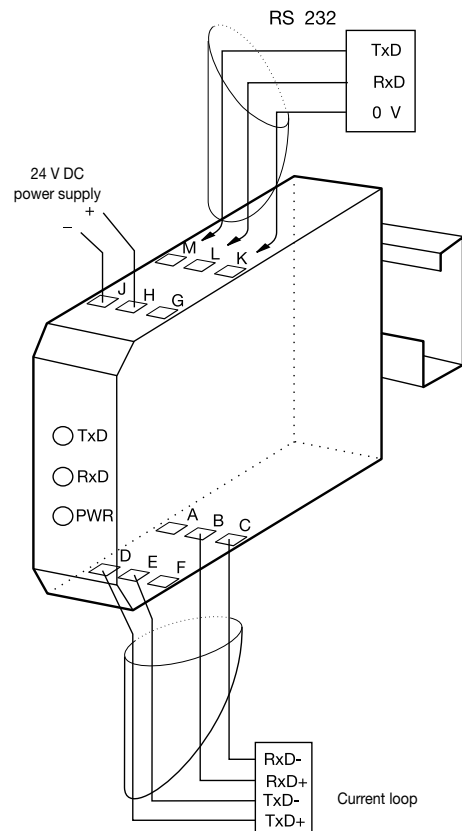
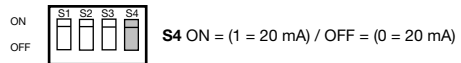

CONNECTIONS

Example of connection with a CL (Current Loop) product, Transmission (TxD) in active mode and Reception (RxD) in passive mode. Then, the ILPH must be configured and connected Reception (RxD) in passive mode and Transmission (TxD) in active mode.

CAUTION : For any other configuration, see schematic diagram or front sticker of the product.

Technical data

Power supply	DC model polarized
Voltage	24 V DC
Voltage tolerance	+/-10%
Supply current	120 mA max.
Connections	Removable screw connector (Omniconnect)
RS 232-1 serial link	EIA RS 232 C / CCITT V 24 V 28
Overtoltage protection	integrated (transil 8 kV 1,2/50 µs)
Baud rate / Transmission distance	max. 38,4 kbit/s / max. 15 m
Connections	2,5 mm² screw (AWG 20)
BdC serial link (current loop) 2	active/passive 0...20 mA / 4...20 mA mode settable
Logic level	0=20 mA or 1=20 mA settable
Baud rate / Transmission distance	max. 38,4 kbit/s / max. 1200 m
Connections	2,5 mm² screw (AWG 20)
Traffic indication	
Voltage	1 yellow LED
Status of signal	2 green LED (RxD, TxD)
EMC behavior	
Electrostatic discharge	EN 61000-4-2 level 3 6/8 kV
Radiated electromagnetic field	EN 61000-4-3 level 3 10 V/m
Burst	EN 61000-4-4 level 3 1 kV
Electromagnetic compatibility	EN 55022 class B
Other characteristics	
Galvanic isolation between	depending on current loop (active/passive)
Current loop / RS 232	500 V DC (active) / 2000 V DC (passive)
Current loop / power supply	500 V DC (active) / 2000 V DC (passive)
Configuration of the operating mode	using internal DIP switches
Operating temperature	0°C ... +50°C
Storage temperature	-25°C ... +80°C
Mounting	any required
DIN rail fixing (EN 50002)	snap-on mounting
Wire size	2,5 mm² / stranded with ferrule, 4 mm² solid
Dimensions (WxDxH)	88 x 22,5 x 100 mm
Weight	100 g