

Thermal Overload relays

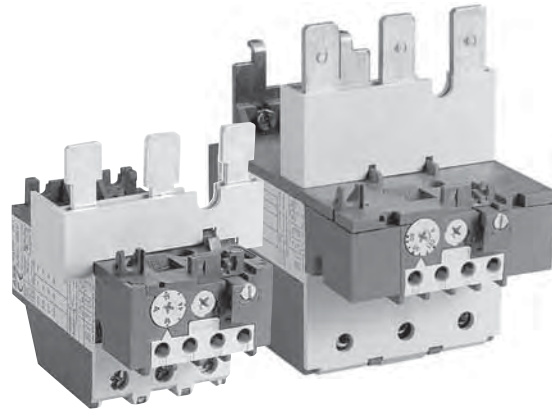

Thermal overload relays

Type TA
Class 10



Description

- Available for starter construction with A Line contactors and separate panel mounting
- Designed for close couple mounting
- Separate base mounting available for all overload relays
- Class 10 adjustable overload relays are standard with all ABB Line starters
- Reset can also be adjusted to function as a stop button
- Screwdriver guide holes
- All terminal screws are available from the front
- UL File No: E48139
- CSA File No: LR98336
- Trip indication
- Remote trip and reset option available
- Single phase and phase unbalance protection
- Isolated alarm circuit (N.O.) contact
- Ambient compensation: -25°C to +55°C (-13°F to +131°F)
- Manual test
- Manual or automatic reset
- Factory calibrated and tested
- Wide adjustment range

Tripping classes of the thermal overload relays

Standard classes in IEC 947-4-1 are classes: 10 A, 10, 20, 30. The tripping class indicates according to IEC 947-4-1 the maximum tripping time in seconds under specified conditions of test at 7.2 times the setting current and specifies tripping and non tripping times for 1.5 and 7.2 times the setting current. Mostly used class is 10 A.

Abstract from IEC 947-4-1

Tripping class	10 A	10	20	30
Max. tripping time at 1.5 x setting current (s) (warm state)	120	240	480	720
Tripping time at 7.2 x setting current (s) (cold state)	2 – 10	4 – 10	6 – 20	9 – 30
At 1.05 x setting current	no tripping			

TA thermal overload relays are used with A Line contactors for the protection of motors having a nominal voltage of up to 600VAC max per UL/CSA (690VAC and 800VDC per IEC).

Product range

• Standard relays:

Types: TA25DU, TA42DU, TA75DU, TA80DU, TA110DU, TA200DU and TA450DU

- TA25 to TA110 and TA200 are directly connected in the motor circuit.
- TA450DU relays are fed through a linear type transformer

• Special construction

Thermal overload relays with different certifications and approvals.
Relays for protection EEx e motors.

Construction and function

• General

Thermal O/L relays and their accessories meet UL, CSA and most other important international standards (IEC), European standards (EN) and the most important national standards (DIN-VDE, NFC-UTE, BS, etc.). They meet the certification and approval directives required throughout the world.

Thermal overload relays are 3 pole. The motor current flows through their bimetals (1 per phase) which are indirectly heated. Under the effect of the heating, the bimetals bend, cause the relay to trip and the position of the auxiliary contacts to change.

The relay setting range is graduated in amps. In compliance with international and national standards, the setting current is the motor nominal current and not the tripping current (no tripping at 1.05 x setting current, tripping at 1.2 times setting current).

The tripping curves (cold or warm starting, 3 phases and 2 phases) are shown on page 2.14.

The relays are built to be self protecting in the event of an overload until the short circuit protection device is activated.

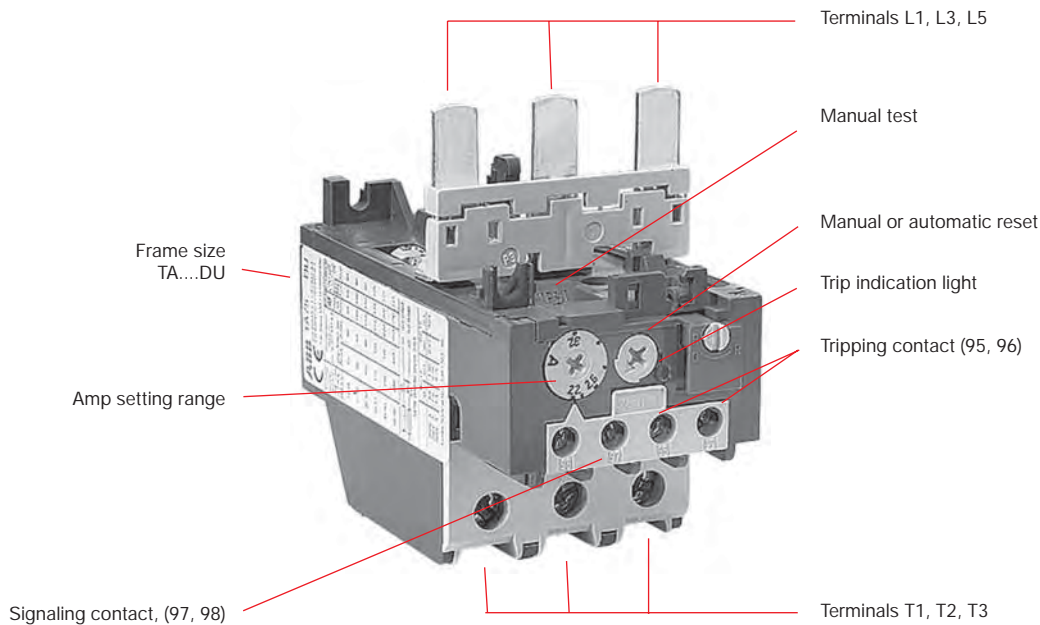

Description

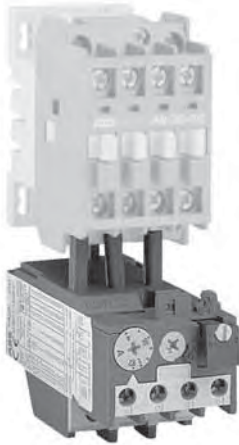

TA25DU

Application

Technical data

• All the relays have:

- Free tripping: the resetting button, even if held in, does not prevent tripping of the thermal overload relay in the event of a fault.
- Temperature compensation
- Phase failure protection according to IEC 947-4-1: Within the limits of the setting range, a reduced tripping time, and thus improved motor protection, is obtained in case of a phase failure.
- Tripping class: 10A, for TA relays
- Test functions and resetting: see table below.

• Auxiliary contacts

The relays have two built in auxiliary contacts: NC marked 95-96; NO marked 97-98. Both contacts are physically separate and can thus be used for 2 different circuits (control circuit and indication circuit).

Function of TA25DU – TA450DU thermal O/L relays

	Resetting Contacts	Relay tripped		Relay not tripped Both manual and automatic
		Manual	Automatic	
Effect of blue button indexed on R (RESET ONLY)	Resetting	Yes	No	No
	95-96	Closed when the button is pressed	No effect	No effect
	97-98	Open when the button is pressed		
Effect of blue button indexed on R/O (RESET/OFF)	Resetting	Yes	No	No
	95-96	Closed when the button is released	No effect	Open when the button is pressed Closed when the button is released
	97-98	Open when the button is pressed		

Selection guide TA25DU – TA80DU

2

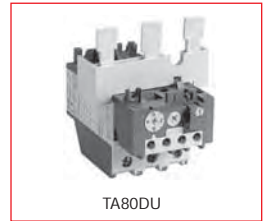
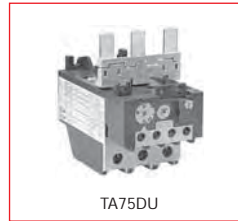
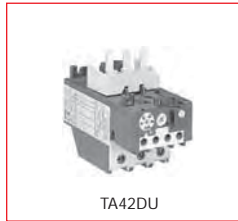
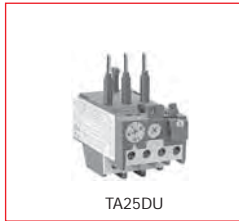

Types

Main characteristics

Construction		3 pole with ambient temperature variation compensation. Protection against single phase operation. Built in auxiliary contacts: 1N.O. + 1N.C.			
Resetting		Convertible: Manual to Automatic			
Setting ranges	Number	18	3	6	4
	from to	0.1 – 0.16A 24 – 32A	18 – 25A 29 – 42A	18 – 25A 60 – 80A	29 – 42A 60 – 80A
Mounted with contactors		No kit is required for mounting thermal O/L relays below contactors			
Mounting kit		No kit is required for mounting thermal O/L relays below contactors			
Types of contactors for combined mounting		A/AE/AL9 A/AE/AL12 A/AE/AL16			
		A/AE/AL26 A/AE/AL30 A/AE/AL40	A/AE30 A/AE40		
				A/AE/AF50 A/AE/AF63 A/AE/AF75	
					A/AE/AF95 A/AE/AF110
Mounted separately (i.e. separate from contactor)					
Separate mounting kit		DB25		DB80	
Accessories					
Tripping coil		DS25-A			
Resetting coil		DR25-A			
Terminal shroud		Terminals protected against direct contact (without the addition of terminal shrouds)			
Function markers				BA5-50	

Selection guide

TA110DU – TA450DU

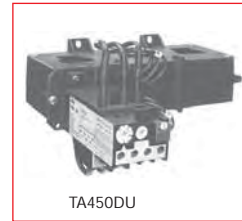
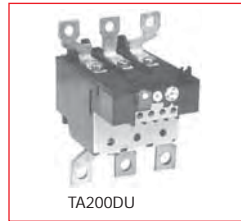
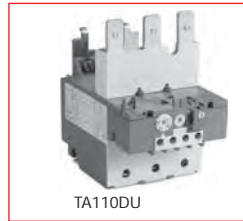

Types

Main characteristics

Construction

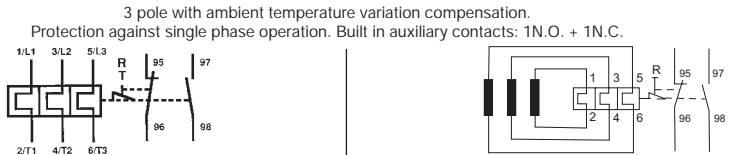

Resetting

Convertible: manual to automatic

Setting ranges

Number	2	6	3
from A	65 – 90	65 – 90	130 – 185
to A	80 – 110	150 – 200	220 – 310

Mounted with contactors

Mounting kit

No kit is required for mounting thermal O/L relays

See page 2.7.

Types of contactors for combined mounting

A/AE/AF95
A/AE/AF110

A/AF145
A/AF185

A/AF210 + DT450/A300
A/AF260 + DT450/A300
A/AF300 + DT450/A300

Mounted separately (i.e. separate from contactor)

Separate mounting kit

DB200

No kit required for separate mounting of thermal O/L relays

Accessories

Tripping coil

Resetting coil

Terminal shroud

Ⓢ

LT200 –

LT450 –

Function markers

BA5-50

Ⓢ Terminals protected against direct contact (without the addition of terminal shrouds)

TA25 - TA450
Class 10
for Contactors A9 – A/AF300



TA25DU



TA42DU



TA75DU



TA80DU



TA110DU

For contactor	Setting range A	Suffix Code	Catalog number	List price
A/AE/AL9 – A/AE/AL40	0.1 – 0.16	A	TA25DU0.16	\$ 63
	0.16 – 0.25	B	TA25DU0.25	
	0.25 – 0.4	C	TA25DU0.4	
	0.4 – 0.63	D	TA25DU0.63	
	0.63 – 1.0	E	TA25DU1.0	
	1.0 – 1.4	F	TA25DU1.4	
	1.3 – 1.8	G	TA25DU1.8	
	1.7 – 2.4	H	TA25DU2.4	
	2.2 – 3.1	J	TA25DU3.1	
	2.8 – 4.0	K	TA25DU4.0	
	3.5 – 5.0	L	TA25DU5.0	
	4.5 – 6.5	M	TA25DU6.5	
	6.0 – 8.5	N	TA25DU8.5	
7.5 – 11	P	TA25DU11		
10 – 14	Q	TA25DU14		
13 – 19	R	TA25DU19		
18 – 25	S	TA25DU25		
24 – 32	T	TA25DU32		
A/AE30 – A/AE40	18 – 25	A	TA42DU25	78
	22 – 32	B	TA42DU32	
	29 – 42	C	TA42DU42	
A/AE/AF50 – A/AE/AF75	18 – 25	A	TA75DU25	102
	22 – 32	B	TA75DU32	
	29 – 42	C	TA75DU42	
	36 – 52	D	TA75DU52	
	45 – 63	E	TA75DU63	
	60 – 80	F	TA75DU80	
A/AE/AF95 – A/AE/AF110	29 – 42	C	TA80DU42	135
	36 – 52	D	TA80DU52	
	45 – 63	E	TA80DU63	
	60 – 80	F	TA80DU80	
	65 – 90	A	TA110DU90	165
	80 – 110	B	TA110DU110	
A/AF145 – A/AF185	65 – 90	A	TA200DU90	165
	80 – 110	B	TA200DU110	
	100 – 135	C	TA200DU135	225
	110 – 150	D	TA200DU150	
	130 – 175	E	TA200DU175	
	150 – 200	F	TA200DU200	
A/AF210 – A/AF300	130 – 185	A	TA450DU185 ①	488
	165 – 235	B	TA450DU235	
	220 – 310	C	TA450DU310	
AF400 – AF750	See electronic overloads, pages 2.21			

① TA450 overloads require mounting kits for installation.

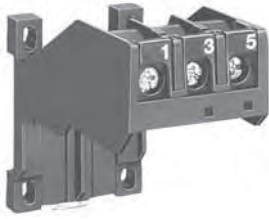

DB25/25A



DB80



DB200



LC26-B1

Separate mounting kits

For O/L relays	Amps	Catalog number	List price
TA25DU	0.1 – 25	DB25/25A	\$ 30
TA25DU	24 – 32	DB25/32A	38
TA42DU, TA75DU, TA80DU	18 – 80	DB80	45
TA110DU, TA200DU	100 – 200	DB200	60

Flat pin terminal blocks

Mounting on:	Catalog number	List price
TA25DU relay DB25/25A or DB25/32A	LC30-T LC26-B1	\$ 6

Terminal block — AWG #8 cable

Mounting on:	Catalog number	List price
TA25DU (25A or less) or DB25/25A	DX25	\$ 15

LC terminal blocks can be used to convert standard connections into Faston connections: 2 x 6.3mm or 4 x 2.8mm per pole. The connections are protected against accidental contact.

The LC30-T has a terminal block for the 3 power terminals and a second for the 4 auxiliary terminals of a TA25DU thermal O/L relay.

The LC26-B1 has two identical terminal blocks each for 3 power terminals. This block allows the power terminals to be mounted with two DB25 kits or a TA25DU thermal O/L relay and DB25 kit assembly.

NOTE: According to DIN 46429 part 1 and NFC 20-120 the max. capacity of a Faston connection is 25 A.

Mounting kit – for TA450 overload relay

For contactor	Catalog number	List price
A145 – A185 A210 – A300	DT450/A185 DT450/A300	\$ 225

Terminal shrouds – for contactors and overload relays

Contactor	Overload relay	Catalog number	List price
A9 – A16 A26 – A40	TA25DU	Included	—
A30 – A40	TA42DU	Included	—
A50 – A75	TA75DU	Included	—
A95 – A110	TA80DU TA110DU	Included	—
A145 – A185	TA200DU	LT185-AY	\$ 10
A145 – A185	Load side of TA200DU	LT200A185	50

Terminal lug kits

Wire range	For overloads	Catalog number	List price
6 – 250MCM	TA110DU, TA200DU	EHTK210	\$ 90
4 – 400MCM	TA450DU185	ATK300HK	78
(2) 4 – 500MCM	TA450DU310	ATK300/2HK	120

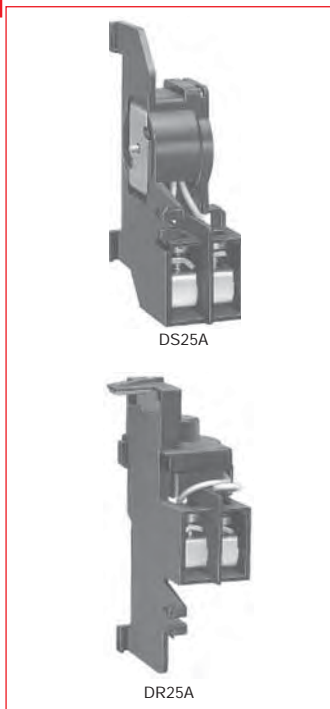

Remote tripping coils

	U voltage at 50/60 Hz	Catalog number ①	List price
DS25-A remote tripping coil	24V	DS25-A-24 DS25-A-48 DS25-A-110 DS25-A-220/380 DS25-A-500	\$ 60
	48V		
	110V		
	220/380V		
	500V		
DS25-A remote resetting coil	24V	DR25-A-24 DR25-A-48 DR25-A-110 DR25-A-220/380 DR25-A-500	\$ 60
	48V		
	110V		
	220/380V		
	500V		

Application

• The DS25-A coil is used for remote electrical tripping of the TA25 DU thermal O/L relay and is connected to the relay's normally closed 95-96 auxiliary contact.

• The DR 25-A coil is used for remote electrical resetting of the TA25DU thermal O/L relay which is adjusted for "Manual resetting;" it is connected to the relay's normally open 97-98 auxiliary contact.

The coils are not designed for continuous duty. Impulse duration: 0.2 to 0.35 s.

Set the button to "Man" (Manual resetting).

Mounting: clipped on to TA25DU thermal O/L relay.

Installation diagrams

For connection of DS25-A to TA25DU relay

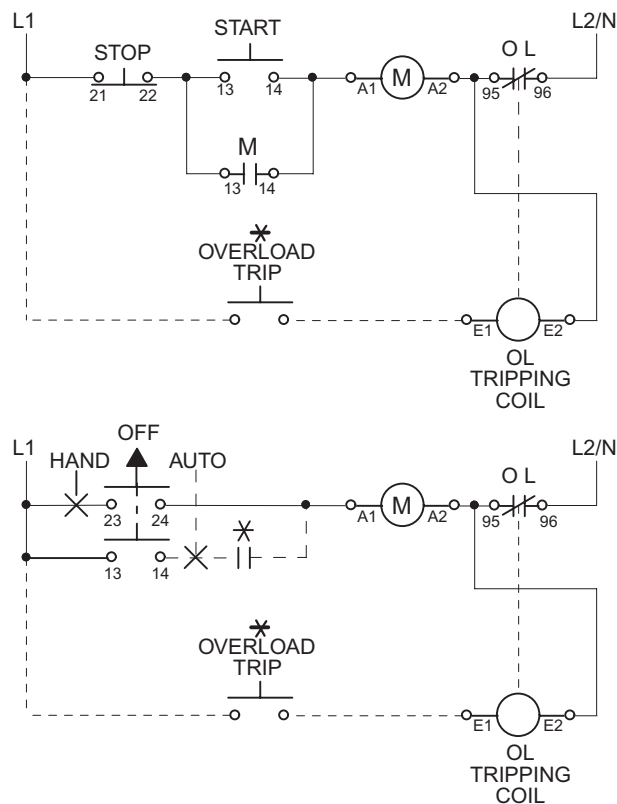

For connection of DR25-A to TA25DU relay

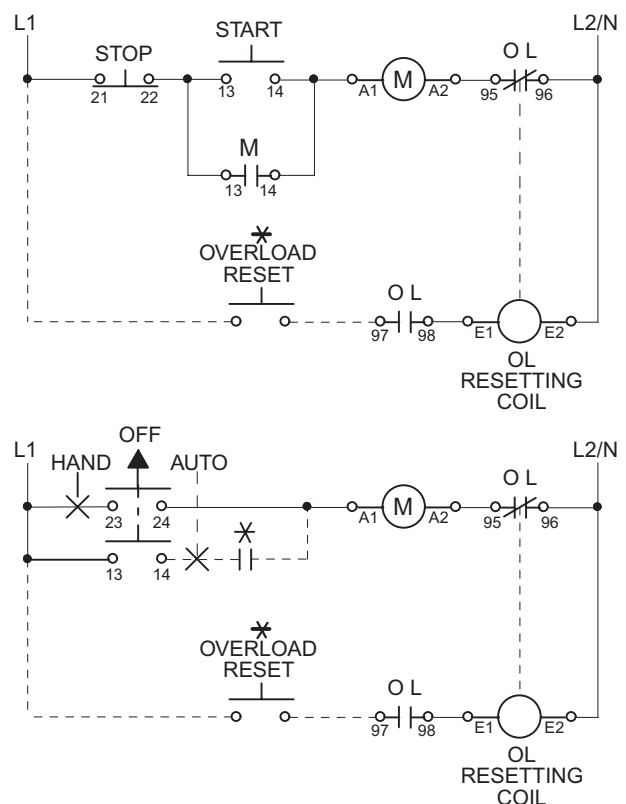

① Cannot be used with TA42, TA75, or TA200 overload relays.

Technical data

TA25DU – TA450DU



Intermittent duty

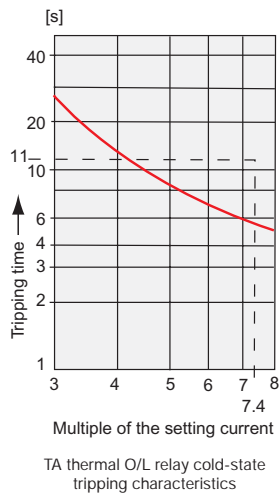
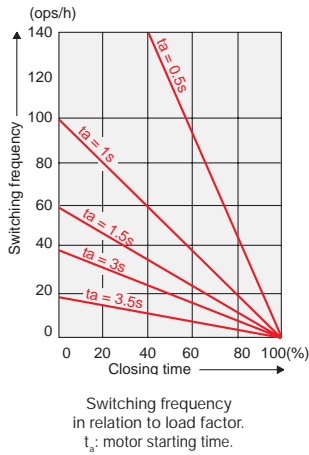

Switching frequency:

To avoid untimely tripping, TA and T thermal O/L relays have been designed to withstand roughly 15 switching operations per hour with an approximately equal distribution between working and rest cycles.

In these conditions, the motor starting time must not exceed 1 second and the starting current must be lower than or equal to 6 times the motor I_n.

For intermittent operations, the diagram opposite specifies relay operating limits.

Example: Motor starting time: 1 sec.

Load factor: 40 %

Switching frequency: 60 ops./h according to diagram

For a higher number of operations and for load variations (e.g. frequent starting and braking), it is advisable to use CUSTORAPID® protection.

For motors subject to particularly severe operating conditions (e.g. locked rotor) it is advisable to use protection combined with a thermal O/L relay and the CUSTORAPID® system.

Protection of motors with long starting time

See electronic overload relay section, pages 2.21 - 2.32.

Mounting position

On a support at an angle of ± 30° in relation to the vertical plane (standard position).

Other mounting positions possible, except mounting on a horizontal plane (in this case the tripping mechanism would be located above the bimetals).

Special version for EEx e motors

Consult factory.

Tripping limits at ambient temperatures varying by + 20°C

Ambient temperature compensation

Thermal O/L relays are compensated against ambient temperature variations by a compensation bimetal which is sensitive to the ambient temperature.

Thermal O/L relays are designed to operate between -5 °C and +40 °C in compliance with standard IEC 947-4-1. For a wider range of -25 °C to +55 °C consult the graph opposite.

Example: tripping at -25 °C. Tripping takes place before 1.5 times the setting current.

Resetting: TA25DU – TA450 DU thermal O/L relays have convertible manual/automatic resetting.

Delivery: in manual resetting mode.

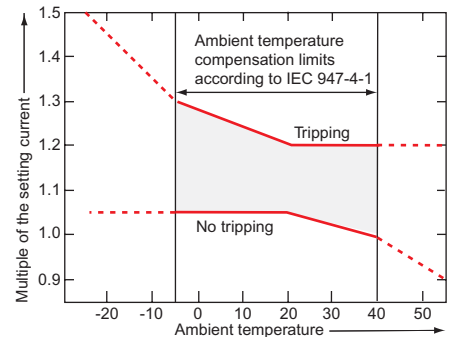

Technical data TA25DU – TA80DU

2

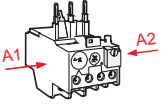
Types	TA25DU	TA42DU	TA75DU	TA80DU
Standards: (international, European)	IEC 947-4-1, EN 60947-4-1			
Rated insulation voltage U_i according to IEC 947-4-1	V	690		
Rated impulse withstand voltage U_{imp} according to IEC 947-4-1	kV	6		
Permissible ambient temperature – for storage – for operation	°C °C	–40 to +70 –25 to +55 with temperature compensation (maximum values: see page 2.9)		
Climatic withstand DIN 50017	Humidity in alternate climate KFW, 30 cycles			
Mounting positions	On a support at an angle of $\pm 30^\circ$ in relation to the vertical plane (standard position). Other positions possible except mounting on a horizontal plane (in this case the tripping mechanism would be located above the bimetals).			
Shock withstand at nominal I_e Critical direction of shocks A1, A2	shock duration ms multiples of g	15 12		
Resistance to vibrations (± 1 mm, 50 Hz)	multiples of g	8		
Mounting – on contactor – separate with DB - kit	Latching below the contactor, screw fixing on main terminals Using screws: 2 x M4 or 35 mm EN 50022			
Terminals and cross-sectional areas for main conductors (motor side)	TA25DU setting ranges: from 0.1-0.16A 24-32 A to 18-25A			
• screw terminal – with cable clamp – via tunnel connector – flat type for lug or bar		M4 – –	– M5 –	M6 – –
• conductor cross-sectional area – rigid solid or rigid stranded – flexible with cable end – recommended bars	mm ² mm ² mm	2 x 1.5 - 6 2 x 1.5 - 4 –	1 x 10 2 x 0.75- 6 –	1 x 2.5 - 35 or 2 x 2.5 x 16 1 x 2.5 - 25 or 2 x 2.5 x 10 –
Terminals and cross-sectional area for auxiliary conductors				
• screw terminal (screw size) – with cable clamp	M 3.5			
• conductor cross-sectional area – rigid solid or rigid stranded – flexible with cable end	2 x mm ² 2 x mm ²	0.75 - 4 0.75 - 2.5		
Degree of protection	All the terminals are protected against direct contact according to VDE 0106/Part. 100. (without additional terminal shrouds)			All the terminals are protected against direct
				direct contact according to VDE0106/part 100 (with additional terminal shrouds for the main terminals)

Pole Technical Characteristics

Types	TA25 DU	TA42 DU	TA75 DU	TA80 DU	TA10 DU	TA200 DU	TA450 DU
Number of poles	3						
Setting ranges	see page 2.6						
Tripping class according to IEC 947-4-1, EN 60947-1	10 A						
Rated operational frequencies	Hz						50/60
Max. switching frequency without untimely tripping	Up to 15 starts/h or 60 starts/h with 40 % on-load factor when neither the starting current of $6 \times I_n$ nor the starting time 1 s are exceeded.						
Resistance per phase in mΩ and heat dissipation in W	see page 2.13						

Technical data TA110DU – TA450DU

Thermal
Overload
relays

2

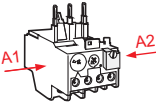
Types	TA110DU	TA200DU	TA450DU		
Standards: (international, European)	IEC 947-4-1, EN 60947-4-1				
Rated insulation voltage U_i according to IEC 947-4-1	V	690	1000		
Rated impulse withstand voltage U_{imp} according to IEC 947-4-1	kV	6	8		
Permissible ambient temperature – for storage – for operation	°C °C	–40 to +70 –25 to +55 with temperature compensation (maximum values: see page 2.9)			
Climatic withstand DIN 50017	Humidity in alternate climate KFW, 30 cycles				
Mounting positions	On a support at an angle of $\pm 30^\circ$ in relation to the vertical plane (standard position). Other positions possible except mounting on a horizontal plane (in this case the tripping mechanism would be located above the bimetals).				
Shock withstand at nominal I_e	shock duration ms	15			
Critical direction of shocks A1, A2	multiples of g	12			
Resistance to vibrations (± 1 mm, 50 Hz)	multiples of g	8			
Mounting – on contactor – separate with DB - kit	4 x M5 screws				
Terminals and cross-sectional areas for main conductors (motor side)		– HC, M8 –	– – M10	– – M10	
• screw terminal – with cable clamp – via tunnel connector – flat type for lug or bar					
• conductor cross-sectional area – rigid solid or rigid stranded		mm ²	16 – 35	25 – 120	2 x 240
– flexible with cable end – recommended bars		mm ² mm	16 – 35 12 x 3	25 – 95 20 x 4	2 x 240 20 x 4...5
Terminals and cross-sectional area for auxiliary conductors		M 3.5			
• screw terminal (screw size) – with cable clamp					
• conductor cross-sectional area – rigid solid or rigid stranded – flexible with cable end	2 x mm ² 2 x mm ²	0.75 - 4 0.75 - 2.5			
Degree of protection	All the terminals are protected against direct contact according to VDE 0106/Part. 100. (with additional terminal shrouds)				

Technical characteristics of auxiliary contacts for thermal O/L relays: TA25DU to TA450DU

Auxiliary contacts		normally closed N.C.	normally open N.O.
Terminal marking		95-96	97-98
Rated operational voltage U_e	VAC	500	500
Conventional thermal current (in free air) I_{th}	A	10	6
Rated operational current I_e , AC-15			
up to 240 V	A	3.0	1.5
up to 440 V	A	1.9	0.95
up to 500 V	A	1.0	0.75
Rated operational current I_e DC-13 up to 250 V	A	0.12	0.04
Protection against short circuits gG (gI) fuses (according to IEC 269)	A	10	6
S 271/S 281 circuit-breaker	A	k3	k1
Maximum potential difference between N.C. and N.O. auxiliary contacts	VAC VDC	500 440	500 440

Technical data

Motor protection; Choice of protective device

2

Motor Protection — general

It is very important to choose an adequate protective device for the safety of the motor during operation and for its durability. The efficiency of protection methods varies according to the application. The overview below will help you to choose. There is no general rule and we are available to advise you for special applications and especially in the case of difficult starting.

Protective devices and efficiency

Protection in relation to current:

Fuses

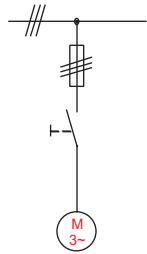

Protective relay with phase fault protection

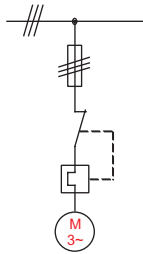

Protection in relation to temperature:

Motor protection via CUSTORAPID® thermistor

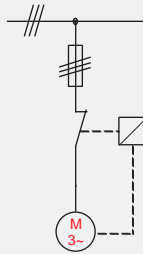

Motor protection via SPEM electronic relay

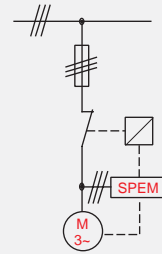

Causes of dangerous overloads for the motor windings

	Fuses	Protective relay with phase fault protection	Motor protection via CUSTORAPID® thermistor	Motor protection via SPEM electronic relay
1 Overload with current 1.2 times the nominal current	☐	●	●	●
2 S1-S8 nominal duties according to IEC 34-I	☐	■	●	●
3 Operation with starting, braking, reversal in operating direction	☐	■	●	●
4 Operation with starting rate at > 15 cycles/hour	☐	■	●	●
5 Locked rotor	■	●	■ for motors with special rotor	●
6 Overloads due to phase failure	☐	●	●	●
7 Network undervoltage or overvoltage	☐	●	●	●
8 Fluctuation of network frequency	☐	●	●	☐
9 Ambient temperature too high	☐	●	●	☐
10 Overheating due to external cause (i.e. overheating of bearings)	☐	☐	●	☐
11 Motor cooling disturbed	☐	☐	●	☐
12				Undercurrent protection on drop in load
13				Protection of asymmetry: wrong phase direction rotation or asymmetrical load
14				Earth fault protection
15				Automatic disconnection for auxiliary load fault

Protection efficiency:

- ☐ unsuitable
- very average efficiency
- perfectly efficient

Note: Fuses

Fuses do not protect motors against overloads. They are only used to protect installations and lines against short circuits.

To ensure efficient protection of a motor against short circuits, it is advisable to use aM type fuses in association with thermal OLR relays.

For the selection of fuses or circuit-breakers, refer to the indications given in this catalogue concerning contactors on the one hand and thermal O/L relays on the other.

In general, fuse protection for direct-on-line starting must be sized as follows:

– aM fuses: choose the fuse rating immediately above the full load value of the motor current.

– gG (gI) fuses: determine the fuse rating immediately above the motor current value and choose the next highest fuse rating.

Technical data

Resistance and Joule losses per phase

Short circuit protection



Resistance and Joule losses per phase, short circuit protection

Setting range current from – to A A	Resistance per phase mΩ	Joule losses per phase at max. setting W
TA25DU		
0.1 – 0.16	85850	2.2
0.16 – 0.25	85150	2.2
0.25 – 0.4	13750	2.2
0.4 – 0.63	5370	2.2
0.63 – 1.0	2190	2.2
1.0 – 1.4	1120	2.2
1.3 – 1.8	670	2.2
1.7 – 2.4	383	2.2
2.2 – 3.1	229	2.2
2.8 – 4.0	137	2.2
3.5 – 5.0	87.5	2.2
4.5 – 6.5	61	2.2
6.0 – 8.5	30.4	2.2
7.5 – 11	18.2	2.2
10 – 14	11.2	2.2
13 – 19	6.3	2.3
18 – 25	4.7	2.9
24 – 32	3.2	3.3
TA42DU		
18 – 25	5.5	3.43
22 – 32	2.89	2.91
29 – 42	1.84	3.24
TA75DU		
18 – 25	5.5	3.43
22 – 32	2.89	2.91
29 – 42	1.84	3.24
36 – 52	1.3	3.51
45 – 63	0.936	3.72
60 – 80	0.615	3.94
TA80DU		
29 – 42	1.84	3.24
36 – 52	1.3	3.51
45 – 63	0.936	3.72
60 – 80	0.615	3.94

Setting range current from – to A A	Resistance per phase mΩ	Joule losses per phase at max. setting W
TA110DU		
80 – 110	0.378	3.78
TA200DU		
100 – 135	0.318	5.79
110 – 150	0.255	5.74
130 – 175	0.214	6.55
150 – 200	0.182	7.28
TA450DU		
130 – 185	—	2.5
165 – 235	—	2.5
220 – 310	—	2.5

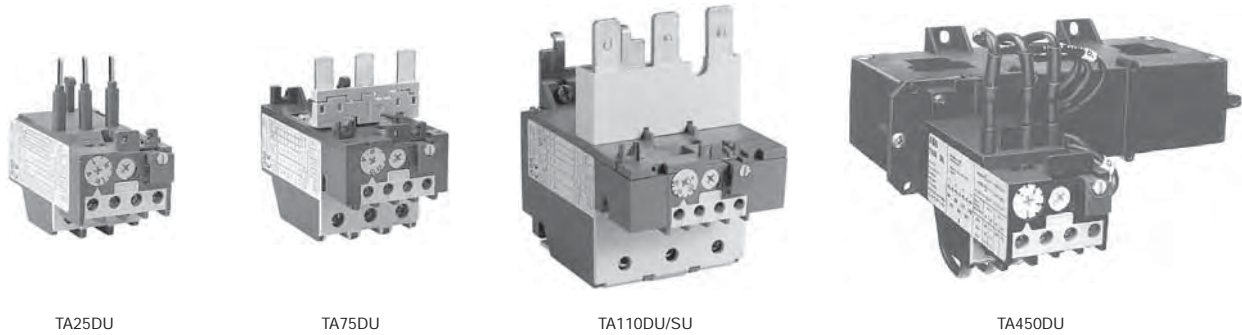

TA-DU thermal O/L relays are 3-pole with manual or automatic resetting mode selection.

The resetting button can also be used for stopping.

Built-in auxiliary contacts are physically separate and, consequently, can be used in different circuits (control circuit/indication circuit).

Each relay is temperature compensated and ensures phase failure protection.

Protective relays up to size TA75DU are protected against direct contact via the front face. Terminal shrouds are available for TA200DU to TA450DU size relays.

The connecting terminals are delivered in open position with (+, -) pozidriv screws and screwdriver guidance. It is advisable to tighten unused terminal screws.

Thermal O/L relay tripping curves

TA25DU
(tripping class 10A)

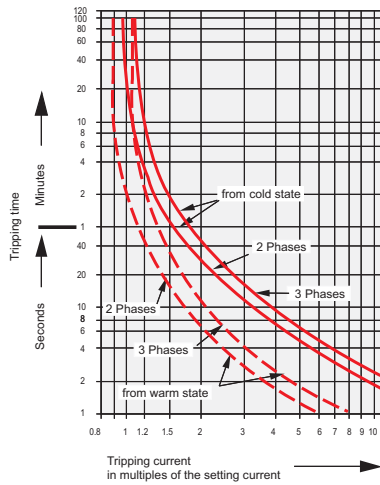

TA42DU, TA75DU and TA80DU
(tripping class 10A)

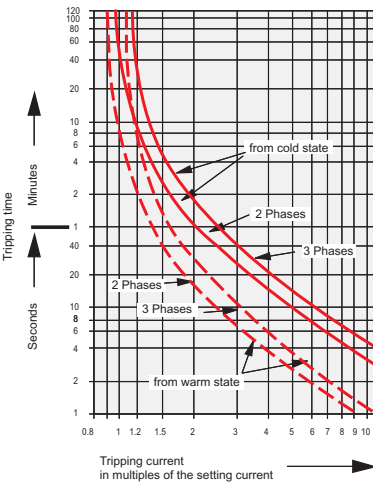

TA110DU
(tripping class 10A)

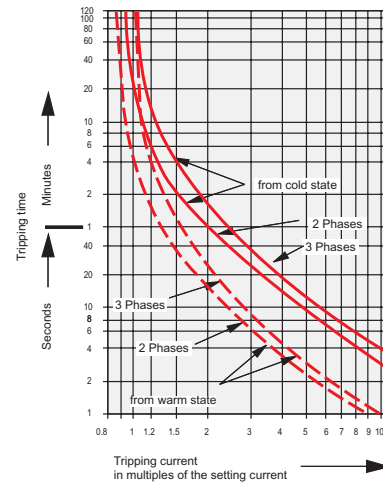

TA200DU
(tripping class 10A)

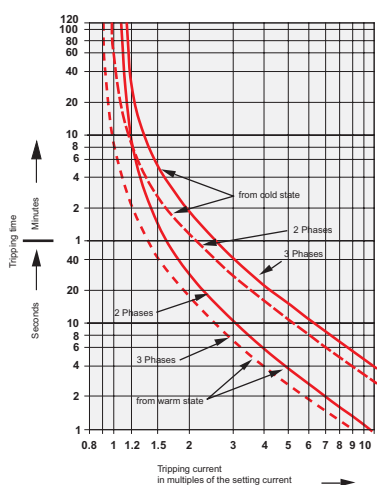

TA450DU
(tripping class 10A)

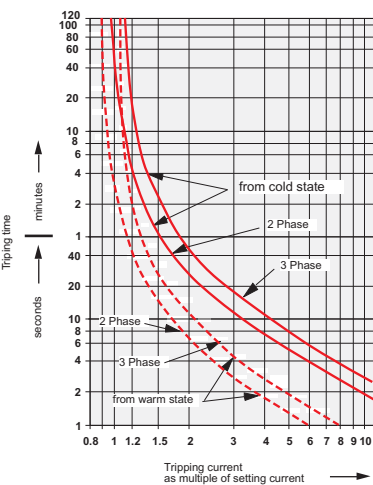

Approximate dimensions T25DU – TA42DU

00.00 Inches
00.00 [Millimeters]

TA25DU

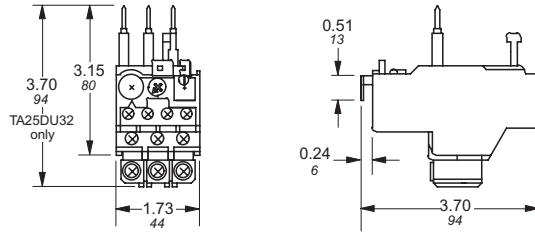

TA25DU & DB25

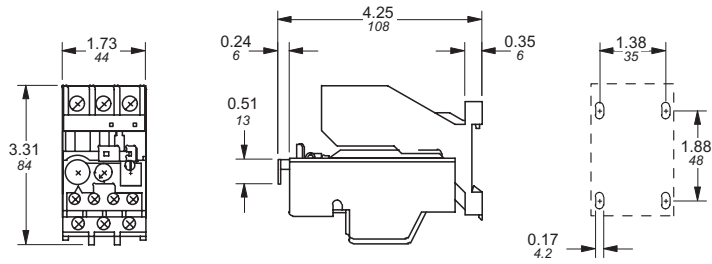

TA25DU & DB25/32

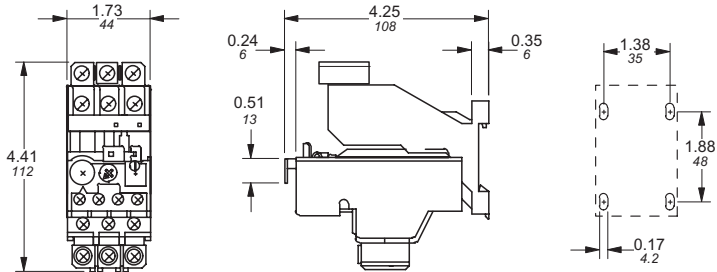

TA42DU

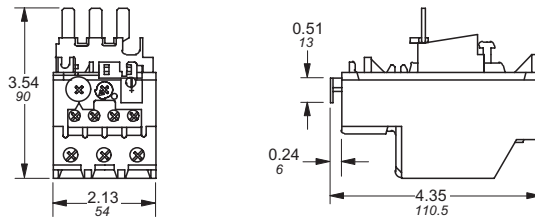

TA42DU / TA75DU & DB80

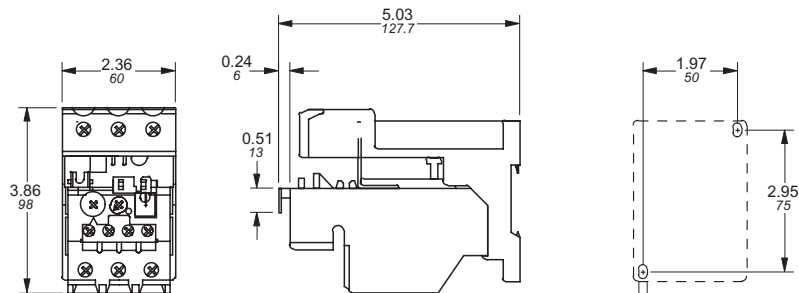

Approximate dimensions TA75DU – TA200DU

← 00.00 → Inches
00.00 [Millimeters]

2

TA75DU

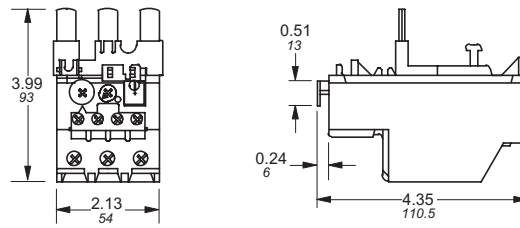

TA80DU

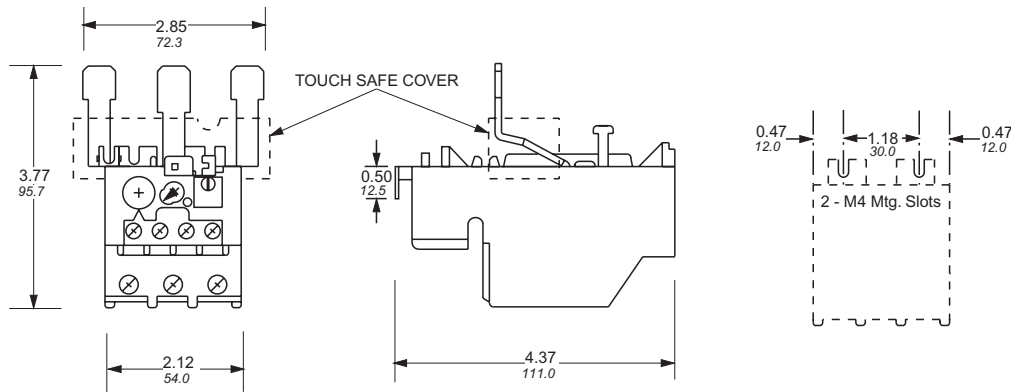

TA110DU

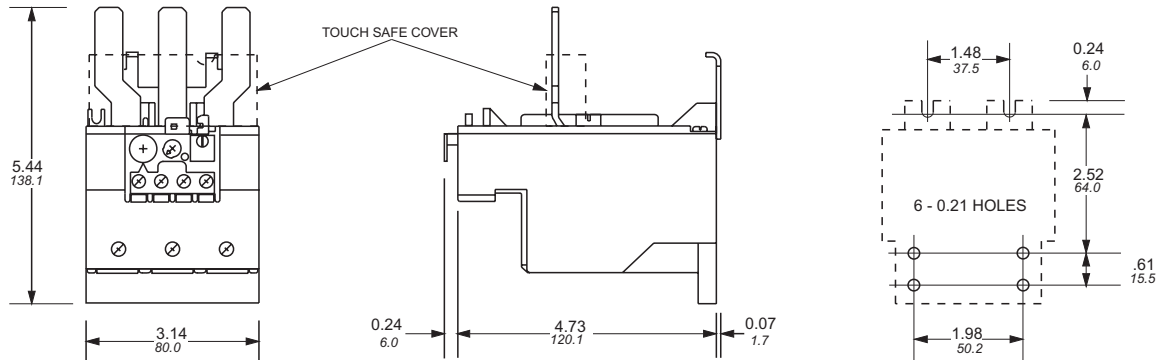

TA200DU

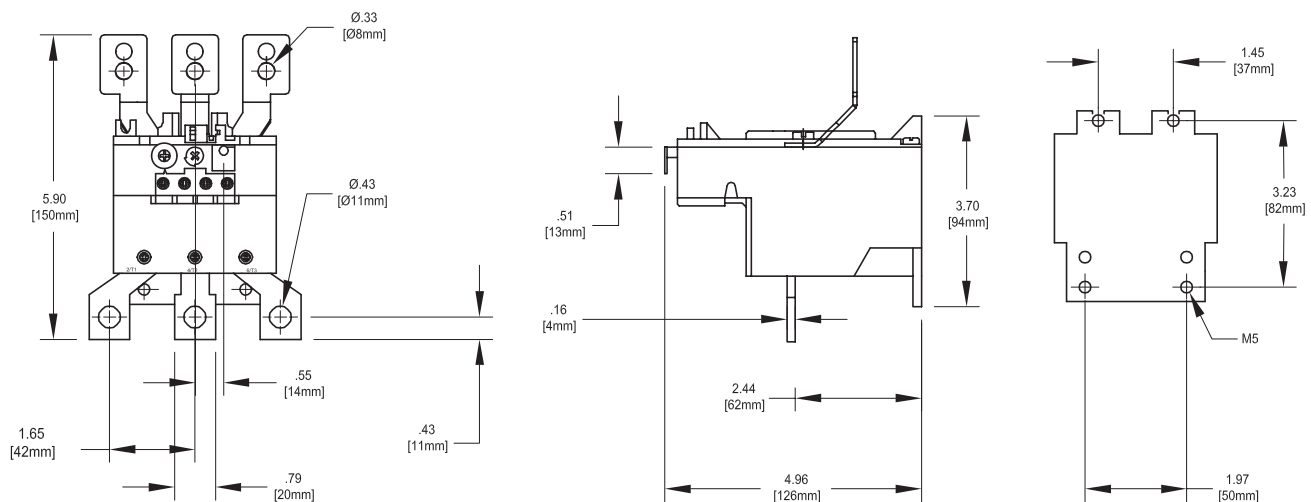

Approximate dimensions TA450DU

Thermal
Overload
relays

00.00 Inches
00.00 [Millimeters]

2

TA450DU

