

Welding isolation Contactors

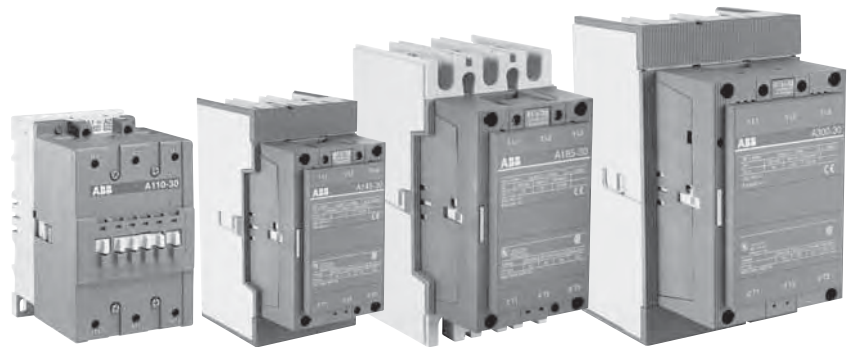

Welding isolation contactors

1



Applications

ABB welding isolation contactors are suited to the rugged demands set forth by the automotive industry and are specifically designed for use in high current welding applications. ABB is the leading contactor supplier for automotive welding applications.

Features

- Includes sizes:
 - W3 thru W6 in 3 pole configurations
 - W4 thru W5 in 2 pole configurations
 - Unique contact design assures reliable and safe operation during high current welding cycles
 - 1 N.O. & 1 N.C. auxiliary contacts are standard and up to 6 additional auxiliary contacts may be added to provide a total of 8 (4 N.O. & 4 N.C.)
 - Easy front removal of arc chute for quick inspection and change of contacts
 - Operates over an extended voltage range of 85% to 110% of rated control voltage
 - UL Listed, File # E79416
 - CSA Certified, File # LR19700
- AW welding isolation contactors can save substantial space compared to other conventional contactors.

140A – 600A 2 & 3 Pole



A110W



A300W



AF460W

3-Pole, A.C.

| Size | Amp rating | Catalog number | List price |
|------|------------|-----------------|------------|
| W3 | 140 | A110W-30-11-84 | \$ 480 |
| — | 200 | A145W-30-11-84 | 825 |
| W4 | 250 | A185W-30-11-84 | 1290 |
| — | 300 | A210W-30-11-84 | 1635 |
| W5 | 350 | A260W-30-11-84 | 1815 |
| — | 400 | A300W-30-11-84 | 1875 |
| W6 | 600 | AF460W-30-11-70 | 4425 |

2-Pole, A.C.

| Size | Amp rating | Catalog number | List price |
|------|------------|----------------|------------|
| W3 | 140 | — | — |
| — | 200 | A145W-20-11-84 | \$ 750 |
| W4 | 250 | A185W-20-11-84 | 1180 |
| — | 300 | A210W-20-11-84 | 1500 |
| W5 | 350 | A260W-20-11-84 | 1675 |
| — | 400 | A300W-20-11-84 | 1750 |
| W6 | 600 | — | — |

Coil voltage selection – wide range AC/DC coils for AF contactors

All AC operated catalog numbers include a 100-250 V AC/DC coil. To select other coil voltages, substitute the code from the Coil Voltage Selection Chart for the two digits after the last dash in the catalog number.

Ex.: A 24V coil is required for a AF460W contactor: AF460W-30-11-68

Coil voltage selection – A contactors

All AC operated catalog numbers include a 120VAC coil. To select other coil voltages, substitute the code from the Coil Voltage Selection Chart for the two digits after the last dash in the catalog number.

Ex.: A 240V coil is required for an A75 contactor: A75-30-11-80

Auxiliary contact blocks

For additional auxiliary contact blocks, see catalog number explanation on page 1.2. Add \$ 20 to list price for each additional auxiliary, and see page 1.18 for available combinations.

Vertical connection bars between 2 pole contactor and MCCB – two bars

| MCCB | For contactor | Catalog number | List price |
|--------|---------------------|-----------------|------------|
| S3, S4 | A145W-20 – A185W-20 | BEA185-20D/S3S4 | \$ 50 |
| S3,S4 | A210W-20 – A300W-20 | BEA210-20D/S4 | 55 |
| S5 | A210W-20 – A300W-20 | BEA300-20D/S5 | 60 |

For other accessories, see page 1.16 to 1.35.

Coil voltage selection chart – A contactors

| Hz | Cntr type | Volts | | | | | | | | | | | | | | | |
|----|-----------|-------|----|----|-----|-----|-----|-----|-----|-----|-----|-----|-----|-----|-----|-----|-----|
| | | 12 | 24 | 48 | 110 | 120 | 125 | 208 | 220 | 240 | 277 | 380 | 415 | 440 | 480 | 500 | 600 |
| 60 | A | | 81 | 83 | 84 | 84 | | 34 | 36 | 80 | 42 | | 86 | 86 | 51 | 53 | 55 |
| 50 | A | | 81 | 83 | 84 | | | | 80 | | | | 85 | 86 | | | 55 |

For other voltages, see page 1.26.

Coil voltage selection – AF50 to AF750

| AC/DC VOLTS, 40 - 60 HZ | | | |
|-------------------------|------------|----------------|-----------------|
| 24 - 60 DC | 20 - 60 DC | 48 - 130 AC/DC | 100 - 250 AC/DC |
| 68 ① | 72 ② | 69 | 70 |

① AF400 – AF750, DC only.

② AF50 – AF300, DC only.

Technical data

| Frame size | A110W | A145W | A185W | A210W | A260W | A300W | AF460W |
|--------------------------------------|-------|-------|-------|-------|-------|-------|--------|
| Amp rating, 50°C | 140 | 200 | 250 | 300 | 350 | 400 | 600 |
| Making capacity, 600 VAC | 1320 | 1740 | 2220 | 2520 | 3120 | 3360 | 4550 |
| Breaking capacity, 480 VAC | 880 | 1160 | 1480 | 1680 | 2080 | 2240 | 4180 |
| Withstand current | | | | | | | |
| RMS | 2500 | 2700 | 2900 | 3200 | 3600 | 4100 | 5800 |
| Peak | 3500 | 3900 | 4100 | 4600 | 5200 | 5900 | 8816 |
| Short time current | | | | | | | |
| 1 second | 1320 | 1800 | 2000 | 2500 | 3100 | 3500 | 4600 |
| 10 seconds | 800 | 1200 | 1500 | 1700 | 2100 | 2400 | 4400 |
| 30 seconds | 500 | 800 | 1000 | 1200 | 1300 | 1500 | 3100 |
| 1 minute | 350 | 600 | 800 | 1000 | 1000 | 1100 | 2500 |
| 15 minute | 175 | 280 | 320 | 400 | 450 | 500 | 840 |
| Coil operating data | | | | | | | |
| A.C. power consumption | | | | | | | |
| Inrush 60 Hz, VA | 450 | 600 | 600 | 1350 | 1350 | 1350 | 800 |
| Holding 60 Hz, VA | 27 | 40 | 40 | 65 | 65 | 65 | 40 |
| Holding 60 Hz, W | 8 | 12 | 12 | 19 | 19 | 19 | 4.5 |
| Maximum short circuit ratings | | | | | | | |
| MCCB | | | | | | | |
| kA @ 480VAC | 85 | 85 | 85 | 85 | 85 | 85 | 84 |
| kA @ 600VAC | 35 | 35 | 35 | 35 | 35 | 35 | 42 |
| Class J fuses | | | | | | | |
| kA @ 600VAC | 200 | 200 | 200 | 200 | 200 | 200 | - |

Approximate dimensions A110W – A300W

00.00 Inches
00.00 [Millimeters]

A110W

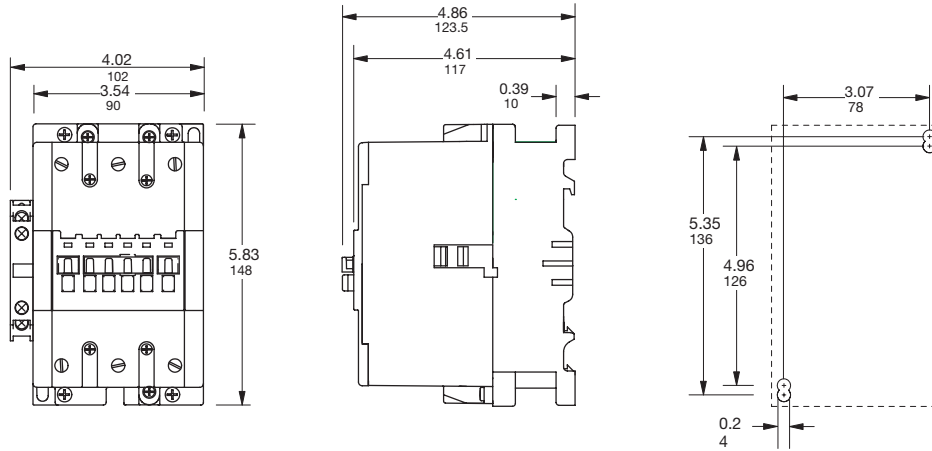

A145W, A185W

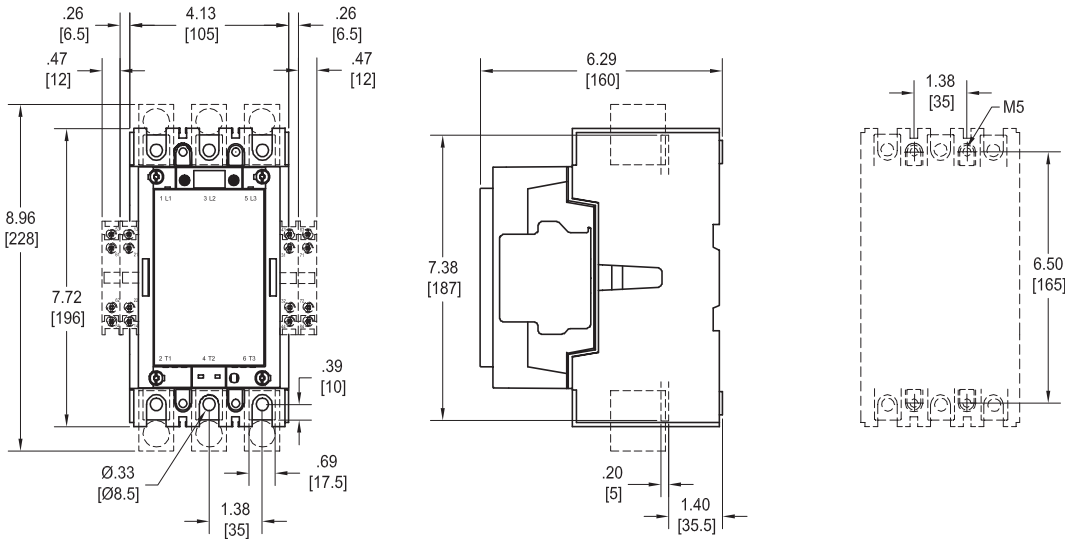

A210W, A260W, A300W

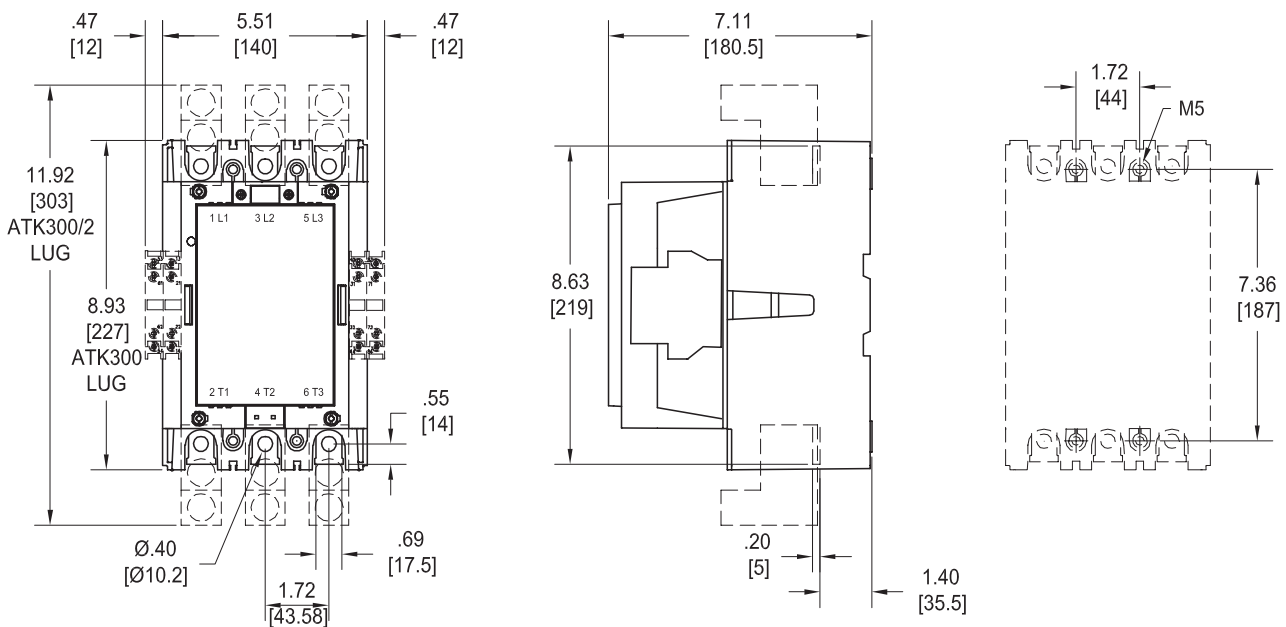

Approximate dimensions AF460W

00.00 Inches
00.00 [Millimeters]

AF460W

