

DR580

Direct Replacement Encoder For Dynapar H23 on Magnetek Vector/Invertor Motors



The Accu-Coder™ Direct Replacement Encoder DR580 is an exact substitute for the Dynapar H23 used on Magnetek Vector/ Inverter Duty motors. Available with CPR's of 1024 or 2048, the DR580 is a heavy duty, rugged industrial encoder capable of withstanding higher temperatures and shock than the Dynapar H23. With either a body mount, or in-line connector option, the DR580 will provide a simple direct fit installation with superior performance for your motor mount application.

DR580	A	1024
MODEL DR580 Size 20 (2.0") Encoder with Flex Mount	CONNECTOR A In-line 10-Pin MS Connector on 15" of Cable B 10-Pin MS Body Mount Connector	CYCLES PER REVOLUTION 1024 CPR 2048 CPR

The Accu-Coder™ DR580 Features:

- Rugged 2" industrial encoder with 2.25" flex mount and 5/8" bore
- Able to withstand temperatures up to 100° C
- Quadrature with index
- Line Driver output
- 5 to 28 VDC
- 10-pin in-line or body mount MS connectors
- Frequency up to 200 kHz
- Sealing to IP64

The Accu-Coder™ Advantage

- Get this encoder **FAST!**
- *Huge savings* in price comparison!
- The accuracy, reliability, and quality that only come from an Accu-Coder™
- Industry Best 3-year warranty!

Model DR580 Specifications

Electrical

- Input Voltage.....4.75 to 28 VDC max for temperatures up to 70° C
 4.75 to 24 VDC for temperatures between 70° C to 100° C
- Input Current.....100 mA max with no output load
- Input Ripple.....100 mV peak-to-peak at 0 to 100 kHz
- Output Format.....Incremental- Two square waves in quadrature with channel B leading A for clockwise shaft rotation, as viewed from the encoder mounting face. See *Waveform Diagrams* below.
- Output Type.....Line Driver- 20 mA max per channel (Meets RS 422 at 5 VDC supply)
- Index.....Occurs once per revolution. See *Waveform Diagram* below.
- Freq Response.....200 kHz
- Noise Immunity.....Tested to BS EN61000-4-2; IEC801-3; BS EN61000-4-4; DDENV 50141; DDENV 50204; BS EN55022 (with European compliance option); BS EN61000-6-2; BS EN50081-2
- Symmetry.....180° (±18°) electrical at 100 kHz output
- Quad Phasing.....90° (±22.5°) electrical at 100 kHz output
- Min Edge Sep.....67.5° electrical at 100 kHz output
- Rise Time.....Less than 1 microsecond
- Accuracy.....Instrument and Quadrature Error: 0.017° mechanical (1.0 arc minutes) from one cycle to any other cycle. (Total Optical Encoder Error = Instrument + Quadrature + Interpolation)

Mechanical

- Max Shaft Speed.....8000 RPM. Higher shaft speeds may be achievable, contact Customer Service.
- Bore Size.....0.625"
- Bore Tolerance.....+0.0006" / -0.0000"
- User Shaft Tolerances
 Radial Runout.....0.007" max
 Axial Endplay.....±0.030" max
- Starting Torque.....1.0 oz-in typical with IP64 seal
- Moment of Inertia.....5.2 x 10⁻⁴ oz-in-sec²
- Max Acceleration.....1 x 10⁵ rad/sec²
- Electrical Conn.....10-pin MS on 15" of cable, or body mount
- Housing.....All metal construction with black protective coating
- Bearings.....Precision ABEC ball bearings
- Mounting.....2.250" Flex mount
- Weight.....11 oz typical

Environmental

- Operating Temp.....0° to 100° C
- Storage Temp.....-25° to +85° C
- Humidity.....98% RH non-condensing
- Vibration.....20 g @ 58 to 500 Hz
- Shock.....75 g @ 11 ms duration
- Sealing.....IP64

DR580 Dimensions

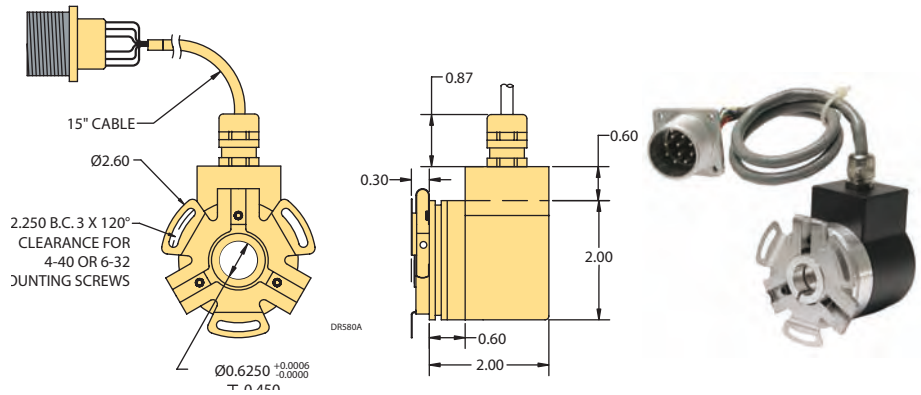

DR580 Dimensions

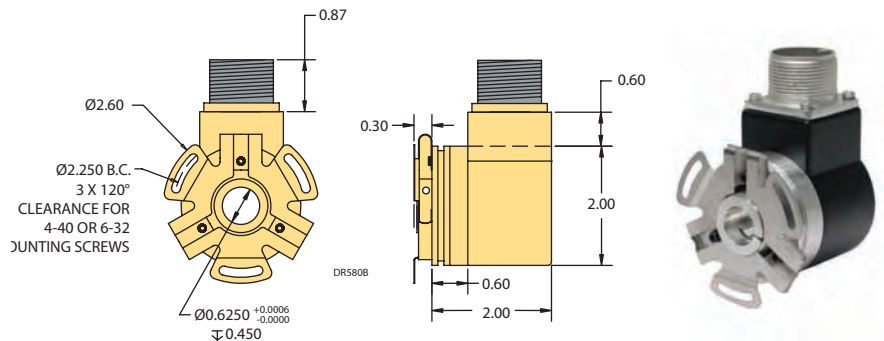

DR580 Waveform Diagram

Line Driver

The Line Driver output waveform is shown in the figure to the right. Output B leads Output A for clockwise rotation, as viewed from the encoder mounting face.

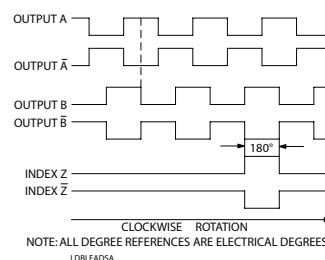

DR580 Wiring Table

Pin	Function	Cable Color
A	A	Violet
B	B	Brown
C	Z	Orange
D	+VDC	Red
E	Shield	Black Tube
F	COM	Black
G	Case	Green
H	A'	Blue
I	B'	White
J	Z'	Yellow

This Direct Replacement Encoder provided by:

