

# 45SD Series Bus Expansion Cards

For use with Q45X Series Photoelectric Sensors on SDS™ Bus Networks



Banner model 45SD plug-in bus cards enable a Banner Q45X Series sensor to establish a logical relationship between the sensor's output and other compatible devices on an SDS™ bus network. 45SD cards are part of a family of bus expansion cards for Q45X sensors which includes models for use on AS-Interface, DeviceNet™, Seriplex®, and other data buses.

Use of a 45SD bus expansion card turns the Q45X into a "smart" sensor which can be connected to an SDS bus network using a simple "dumb drop" junction box or a "T" connector. Plugging a bus expansion card into a Q45X Series sensor automatically converts the basic sensor outputs to a pair of datacom connections with the proper protocol for use on an SDS™ bus network. Q45X sensors *without* bus cards (i. e. "dumb sensors") may also be added to any bus system, via a "smart drop" junction box. Basic Q45X sensors (without bus expansion cards) interface directly to PLC dc inputs. See the functional schematics on the other side of this data sheet. The block diagram at the right illustrates how "smart" and "dumb" Q45X Series sensors can be mixed together on the same bus network.

On a Q45X Series sensor with a 45SD1 expansion card installed, a green LED lights to indicate POWER ON, and a red LED indicates received light signal strength by means of Banner's patented† AID™ system (see below).

NOTE: The yellow sensor LED is disabled when a bus network card is installed.

Emitter model Q45X6EQ has green indicator only.

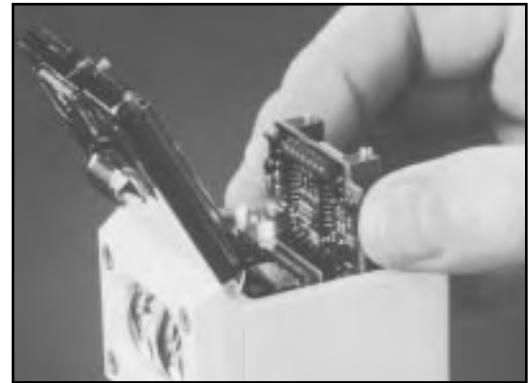

SDS™ is a trademark of Honeywell Micro Switch Division

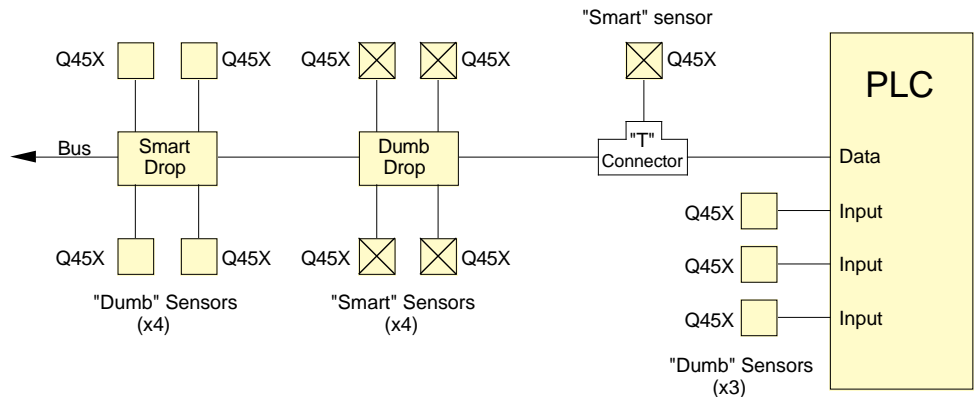

Model	Part No.	Used with Sensor	Communication
45SD1	40060	All Q45XB6 models, except emitter	SDS level 4 binary input 1.1.1.5
45SDE1	40908	Q45X6EQ emitter	Allows emitters to be powered from the bus; not communicate

## Specifications, Q45X Series Sensors using 45SD Expansion

Card (see Q45X data sheet, p/n 37735, for further information).

### Supply voltage and current:

The sensor is powered by the bus network (11 to 25V dc; 60 mA combined current for Q45X sensor and 45SD card).

**Output configuration:** Standard CAN transceiver, non-isolated. Conforms to SDS™ protocol.

**Circuitry protection:** Protected in the event of reverse power supply polarity and loss of ground (neither condition will harm the sensor or interrupt other communications on the network).

**Sensor response time:** 2 milliseconds. The *total* response time is the sum of the sensor response time and the network response time.

### Status indicators (visible through transparent sensor top cover):

A green LED lights to indicate POWER ON; a red Banner AID™ System (†U.S. patent no. 4356393) LED lights when the sensor is seeing its modulated light source, and pulses at a rate proportional to the strength of the received light signal. Emitter model Q45X6EQ has green indicator only.

**Cable:** Sensors require SDS™ 5-pin mini-style quick disconnect cable, available from Turck, Lumberg, or Brad Harrison (see page 2).

**Operating temperature range:** -10 to +70°C (14 to +158°F)

**Relative humidity:** 0 to 95%, non-condensing

# 45SD Bus Expansion Cards

## Installation and Removal, 45SD Plug-in Bus Expansion Card

### Installation

Modules are installed through the top of the sensor.  
The procedure is as follows:

- 1) Remove power from the sensor.
- 2) Loosen the top cover hold-down screw and raise the cover. The cover is hinged at the front.
- 3) Using a small screwdriver inserted into one of the slots at the rear of the inside black cover, lift up and remove the black inside cover (Photo 1).
- 4) Insert the card in the expansion slot so that the connector receptacles on the card align with the connector pins inside the sensor. Slide the card down into the slot until the connectors are fully engaged. (Photo 2).
- 5) Replace the original black inside cover with the one supplied with the 45SD card.
- 6) Ensure that the sensor's LO/DO (light/dark operate selector) switch is in the LO position.
- 7) Place one of the stick-on labels (provided) over the SDS logo on the black cover. Write the sensor's network address on the label.

Photo 1.

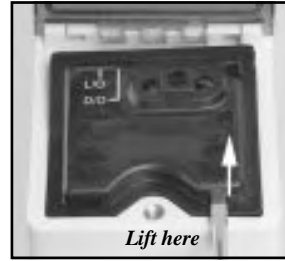

Photo 2.

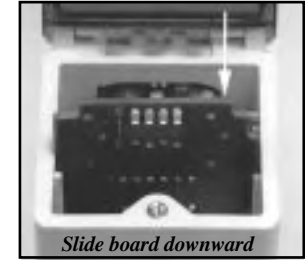
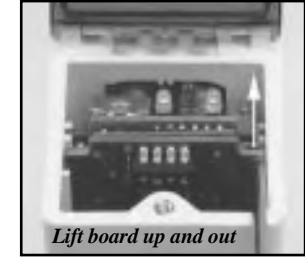

Photo 3.



### Removal

Modules are removed through the top of the sensor. The procedure is as follows:

- 1) Follow steps 1 through 3 of the Installation Procedure, above.
- 2) Insert a small, flat bladed screwdriver or similar tool into the lift slot on the edge of the expansion card (Photo 3). Gently pry up to disconnect the card, and then lift it out.

## Functional Schematic

### Q45X Bus Configuration (bus card installed)

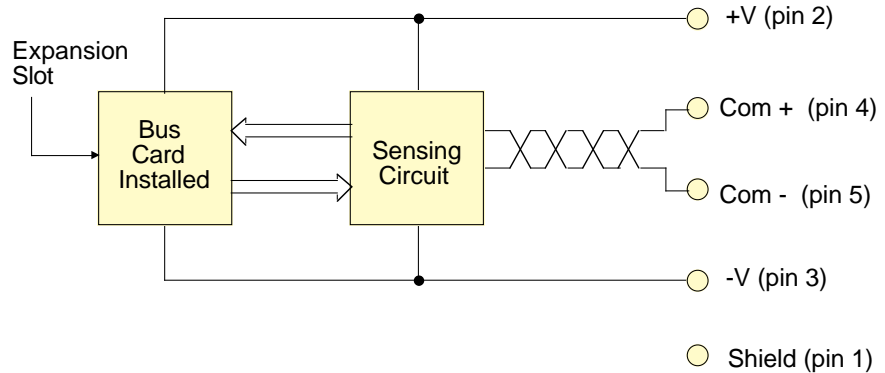

## Quick-disconnect Cable

### Q45X sensor hookup, 45SD expansion card installed (Q45X base, male connector):

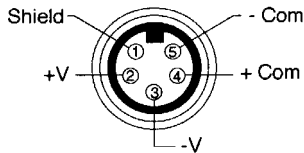

Pin	Wire*	Function
1		Shield
2	Brown	BUS power (+V)
3	Blue	BUS power (-V)
4	Black	Communications +
5	White	Communications -

The Q45X sensor with 45SD expansion card installed requires SDS™ compatible quick disconnect cable, which is available from various manufacturers including Turck, Brad Harrison, and Lumberg.

\*Wire colors in the table above are for SDS™ compatible cable only.

# SDS Model Specification for 45SD1 Bus Card



The 45SD card conforms to the following SDS model:  
Level 4 Binary Input, 1.1.1.5

## ATTRIBUTES

<i>Attribute</i>	<i>Description</i>	<i>R/W</i>	<i>Data Type</i>	<i>Size</i>	<i>Count</i>	<i>Default value</i>
0	Network Data Descriptor	R	Uns.	Byte	6	18,1,0,0,0,0
1	Baud Rate	R	Uns.	Byte	1	0
2	Object Type	R	Uns.	Byte	4	1,1,1,5
3	Partner ID	R	Uns.	Word	1	50
4	Device Address	R	Uns.	Byte	1	125
6	Unsolicited Mode Enable	R/W	Bool.	Und	1	1
7	Software Version	R	Char.	Und	11	38741 - X.X
8	Diagnostic Error Counter.	R	Uns.	Byte	1	
9	Diagnostic Register	R/W	Uns.	Byte	2	
10	Cyclic Timer	R/W	Uns.	Byte	1	0
11	Serial Number	R	Uns.	Long	1	XX...X
12	Date Code	R	Char.	Und	4	MMYY
13	Catalog Listing	R	Char.	Und	24	45SD1, Q45X
14	Partner Name	R	Char.	Und	24	"Banner Engineering"
15	Component Name	R	Char.	Und	24	"Photoelectric Sensor"
18	Input Data	R	Bool.	Und	1	-
51	Direct Input State	R	Uns.	Byte	1	-
56	Tag Name	R/W	Char.	Und	24	Blank
58	Diagnostic Count Limit	R/W	Uns.	Byte	1	1
61	Configuration Register	R/W	Uns.	Byte	1	0

**0 I/O Type:** 18,1,0,0,0,0 These six bytes indicate that this is a single point binary input with the input variable at Attribute #18.

**1 Baud Rate:** Always returns 0. This indicates that this device automatically determines the correct baud rate for communication.

**2 Device Type:** Indicates type of device in terms of the SDS protocol. This is presented as 4 X 8 bit words: 01,01,01, 05 hex.

**3 Vendor Identification Number:** 50 decimal.

**4 Device Address:** This variable indicates the devices network address 0-125. It is the logical SDS address - 1. If the SDS address of this device is 1 this attribute will be 0. Default value is 125 decimal. This attribute is stored in non volatile memory.

**6 Unsolicited Mode Enable:** Setting this bit allows the device to send I/O event driven messages. These event messages include: COS ON, COS OFF, WRITE ON, WRITE OFF. If this bit is cleared then only the error event (event 0) is generated, all other events will be disabled. This attribute is stored in non volatile memory.

**7 Software version Number:** ASCII character string "38741-X.X"

**8 Diagnostic Error Counter:** The Diagnostic Error counter indicates the number of errors flags that are currently set in attribute # 9. The possible values of this counter are 0,1,2,3 or 4.

**9 Bus Diagnostics Register:** This is a 2 byte read only register. When an error occurs, the corresponding bit is set.

Byte 1

bit 0 ROM Checksum Error

bit 1 not used = 0

bit 2 Off-Bus error

bit 3 reserved = 0

bit 4 reserved = 0

bit 5 not used = 0

bit 6 not used = 0

bit 7 EEPROM Failure

Byte 2

bit 0 not used = 0

bit 1 not used = 0

bit 2 not used = 0

bit 3 reserved = 0

bit 4 reserved = 0

bit 5 not used = 0

bit 6 Low Gain Alarm

bit 7 not used = 0

**10 Cyclical Timer:** Setting to a non zero value will enable unsolicited WRITE-ON or WRITE-OFF messages to be transmitted with a real time interval equal to 10.24 ms times the set value. These messages will reflect the current state of the input variable (attribute #18). This attribute is stored in non volatile memory.

**11 Serial Number:** Unique number used to differentiate products prior to address assignment. The firm ware waits for a random period of up to 10 ms before responding to a read of this attribute. This makes it possible to detect two nodes with the same address.

**12 Date Code:** ASCII string that identifies date of manufacture.

**13 Catalog listing:** ASCII string = "Q45X, 45SD1".

**14 Vendor Name:** ASCII String = "Banner Engineering".

**15 Device Name:** ASCII String = "Photoelectric Sensor".

**18 Input Variable:** This reflects the state of the sensors output, 0 = Dark, 1 = Light. The logical state of this attribute can be inverted by setting attribute 61, NO/NC. The state of this attribute may also be forced by using action 51, Force State.

**51 Direct Input State:**

This is a single byte, 8 flags.

**bit 0** Real time sense level, high when excess gain > 1

**bit 1** Real time diagnostics signal, high when excess gain > 2.5 ( Sensor sees Light and Alarm is off)

**bit 2-7** = 0, not used.

Possible values of Attribute 51 are:

51 = 0 Dark

51 = 1 Low Gain

51 = 3 Light

The NO/NC bit (attribute #60) does not affect this register.

**56 Tag Name:** This is a read/write 24 character ASCII string. This attribute is stored in non volatile memory.

**58 Diagnostic Count Limit:** Each time a low gain condition occurs, it is counted. When that count reaches the diagnostic count limit, the diagnostic register is updated and an event 0 is sent. Here are some possible values for the diagnostic count limit:

0 = Low gain alarm disabled;

1 = Low gain bit set each time low gain condition occurs;

20 = Low gain bit is set after 20 low gain conditions.

## 61 Configuration Register:

This is a single byte, 8 flags.

**bit 0 - 2** not used.

**bit 3** Disable re-transmission of COS messages R/W . When this bit is set ALL event driven messages are sent only once per event. Unacknowledged messages are not resent.

**bit 4 - 7** not used.

This attribute is stored in non volatile memory.

## ACTIONS

<i>Action</i>	<i>Description</i>	<i>Requested Data</i>	<i>Requested Data Type</i>	<i>Response Data</i>	<i>Response Data Type</i>
<b>0</b>	No Operation	None		None	
<b>1</b>	Change Address	New Address Device ID* Partner ID* Serial No.*	Unsigned 8 Unsigned 8 Unsigned 16 Unsigned 32	None	
<b>2</b>	Self Test	None		None	
<b>6</b>	Clear All Errors	None		None	
<b>8</b>	Enroll Logical Device	None		Partner ID Serial No.	Unsigned 16 Unsigned 32
<b>51</b>	Force Input	Input State	Unsigned 8	None	
<b>52</b>	Remove Forced Input	None		None	
<b>53</b>	Read Primitive Tag	Attribute ID		Attribute ID Primitive tage	Unsigned 8 Unsigned 32

\* These parameters are optional

**0 NO-OP:** This is used primarily during “Autobaud” and to solicit a response from another node to verify bus integrity. No action is performed by our device.

**1 Change Address:** There are two methods to change the address.

- If the message contains one or two data bytes the address is changed to the address defined by the first byte. The second byte is ignored.
- If the message contains eight data bytes, then bytes 3 and 4 are checked against the Vendor ID. Bytes 5-8 are checked against the Serial Number. If the Vendor ID and Serial Number are correct, then byte 1 is used to determine the new address. If either is not correct the message is ignored.

**2 Initiate Self Test:** This action initiates a self test sequence internal to the node. This action is acknowledged prior to the start of the self test. An Event ID 0 is then transmitted only if internal errors are found.

**6 Reset Errors:** This action clears the error flags in both bytes of attribute #9, Bus Diagnostic Register.

**8 Enroll:** Enroll returns a 6 byte message. The first four data bytes are the Serial Number and the remaining two bytes are the Vendor Identification Number. The firmware waits for a random delay, up to 10 ms, before responding to this action. This delay makes it possible to detect multiple devices with the same logical address.

**51 Force Input/Output Variable State:** This forces the logical state of the Input, Attribute #18. The data contains a Boolean single byte: 00 or 01.

**52 Remove Force Input/Output Variable State:** This function removes the forced state, and restores normal operation.

**53 Read Primitive Tag:** This action is called with one byte of input data - the attribute number. This action responds with the following 3 bytes of data: Attribute # (unsigned 8), Primitive Tag (unsigned 16).

## EVENTS

<i>Event</i>	<i>Description</i>	<i>Output Data Parameters</i>	<i>Output Data Parameter Type</i>
<b>0</b>	Diagnostic Event Counter	Counter Value	Unsigned 8
	Write ON	None	
	Write OFF	None	
	Change of State ON	None	
	Change of State OFF	None	

**0 Diagnostic Event Counter:** This event is sent when ever a flag in attribute 9 is set. This event also sends one data byte. This byte contains the value of attribute #8, the Diagnostic Error Counter. Typically, this event is sent as a result of a low gain condition.

**Write ON/OFF:** These events are sent when the Cyclic Timer has expired. Either a WRITE ON or a WRITE OFF special event is sent reflecting the state of the input. This event can be masked by clearing attribute 6.

**Change Of State ON:** When the output of the sensor transitions to the ON state this message is sent. This event can be masked by clearing attribute 6.

**Change Of State OFF:** When the output of the sensor transitions to the OFF state this message is sent. This event can be masked by clearing attribute 6.

WARRANTY: Banner Engineering Corporation warrants its products to be free from defects for one year. Banner Engineering Corporation will repair or replace, free of charge, any product of its manufacture found to be defective at the time it is returned to the factory during the warranty period. This warranty does not cover damage or liability for the improper application of Banner products. This warranty is in lieu of any other warranty either expressed or implied.