



# DUO-TOUCH® Run Bar with STB Buttons

Self-Checking Ergonomic Actuating Devices



## Features

- Ergonomic design for reduced hand, wrist, and arm stresses associated with repeated switch operation; requires no physical pressure to operate
- Designed to minimize the possibility of defeat and accidental actuation
- Designed to comply with ANSI B11.19 and ISO 13851 (EN 574)
- Robust 13 gauge (0.090") cold-rolled steel construction
- Models available with IP20 or IP65 construction
- Two diverse-redundant microcontroller-based photoelectric STB self-checking touch buttons:
  - Continuous internal self-checking operation
  - Immunity to ambient light, EMI and RFI interference
  - High excess gain to cut through heavy contamination
  - LED power, output, and fault indicators
- Emergency stop button on some models
- Designed to be interfaced with DUO-TOUCH SG two-hand control modules or other control systems that comply, at minimum, with ANSI NFPA 79 or IEC 60204-1 two-hand control requirements (e.g., anti-tie down)
- Accessory EZ-LIGHT™ with blue, red, green, and amber LEDs available
- Accessory brackets and telescoping floor-mounted stands available

## Models

Model	Run Bar Description	Touch Button Description	E-Stop Button	Connections
STBVP6-RB1	DUO-TOUCH Run Bar, IP20 metal construction	Two model STBVP6 optical touch buttons (solid-state complementary PNP outputs, polyetherimide upper housing)	Not included	Terminal strip connection
STBVP6-RB1E02			Model SSA-EBM-02L E-stop button (two NC safety contacts)	
STBVP6-RB1Q8			Not included	8-pin Mini-style QD
STBVP6-RB2	DUO-TOUCH Run Bar, IP65 metal construction		Not included	Terminal strip connection
STBVP6-RB2E02			Model SSA-EBM-02L E-stop button (two NC safety contacts)	
STBVP6-RB2Q8			Not included	8-pin Mini-style QD
DUO-TOUCH® Run Bar Kits	Call for assistance and availability			

\* See page 12 for brackets and stand options.



### WARNING . . . Not a Stand-Alone Safety Device

STB Series Touch Buttons are self-checking ergonomic actuating devices, but are not, by themselves, safety devices. To be used in a safety application, two STBs must be interfaced with a type IIC two-hand-control module or system, such as the Banner AT-FM-10K, in order to meet all relevant safety requirements of the appropriate standards.

# DUO-TOUCH® Run Bar with STB Buttons

---



## Important ... read this page before proceeding!

In the United States, the functions that a Banner DUO-TOUCH Two-Hand Control System is intended to perform are regulated by the Occupational Safety and Health Administration (OSHA). Whether or not any particular DUO-TOUCH SG Two-Hand Control installation meets all applicable OSHA requirements depends upon factors that are beyond the control of Banner Engineering Corp. These factors include the specific ways the system is applied, installed, wired, operated, and maintained.

Banner Engineering Corp. has attempted to provide complete application, installation, operation, and maintenance instructions. In addition, we suggest that any questions regarding the use or installation of this two-hand control safety system be directed to the factory applications department at the telephone numbers or address shown on the back cover of this manual.

The user of this Two-Hand Control safety system must ensure that all machine operators, maintenance personnel, electricians, and supervisors are thoroughly familiar with and understand all instructions regarding the installation, maintenance, and use of this system, and with the machinery upon which it is installed.

The user and any personnel involved with the installation and use of this safety system must be thoroughly familiar with all applicable OSHA regulations and ANSI standards. The regulations and standards, listed below, directly address the use of two-hand control systems. Banner Engineering Corp. makes no claim regarding a specific recommendation of any organization, the accuracy or effectiveness of any information provided, or the appropriateness of the provided information for a specific application.

The user has the responsibility to ensure that all local, state, and national laws, rules, codes, and regulations relating to the use of this Two-Hand Control system are satisfied. Extreme care is urged that all legal requirements are met and that all installation and maintenance instructions contained in this manual are followed.

### U. S. Standards Applicable to Use of Two-Hand Control Systems

ANSI B11 Available from:	Standards for Machine Tools "Safety Requirements for the Construction, Care and Use" Safety Director AMT – The Association for Manufacturing Technology 7901 Westpark Drive McLean, VA 22102 Tel.: 703-893-2900 Fax: 703-893-1151
NFPA79 Available from:	"Electrical Standard for Industrial Machinery" National Fire Protection Association 1 Batterymarch Park, P.O. Box 9101 Quincy, MA 02269-9101 Tel.: 800-344-3555
ANSI/RIA R15.06 Available from:	"Safety Requirements for Industrial Robots and Robot Systems" Robotic Industries Association 900 Victors Way, P.O. Box 3724 Ann Arbor, MI 48106 Tel.: 734-994-6088

### International (European) Standards Applicable to Use of Two-Hand Control Systems

ISO/12100-1 & -2	"Safety of Machinery – Basic Concepts, General Principals for Design, Part 1: Basic Terminology, Methodology" Part 2: Technical Principals and Specifications"
EN60204-1	"Electrical Equipment of Machines: Part 1: General Requirements" Also, request a type "C" standard for your specific machinery.
ISO13849-1	"Safety of Machinery – Safety Related Parts of Control Systems"
ISO13855 (EN999)	"Safety of Machinery – The Positioning of Protective Equipment"
ISO13851 (EN574)	"Safety of Machinery – Two-Hand Control Devices"
Available from:	Global Engineering Documents 15 Inverness Way East Englewood, CO 80112-5704 Tel.: 800-854-7179

# DUO-TOUCH® Run Bar with STB Buttons

---

## Description

The DUO-TOUCH® Run Bar with STB Self-Checking Optical Touch Buttons is designed to satisfy the ergonomic principles found in ANSI B11.TR1 to reduce the hand, wrist, and arm stresses associated with mechanical push buttons. The rugged 13-ga. steel housing is designed to prevent inadvertent switch actuation due to objects (such as loose clothing or debris) which might accidentally block the sensing beam.

The STB Touch Buttons are touch-activated photoelectric devices designed to replace capacitive touch switches and mechanical push buttons. Their outputs activate when a finger is present in the yoke (“touch area”) of the switch, interrupting the button’s infrared sensing beam. These “buttons” require absolutely no physical pressure to operate, and are immune to EMI, RFI, and ambient light interference (see specifications on page 10).

The STB button’s internal design incorporates dual microcontrollers, allowing hookup to a Banner DUO-TOUCH SG Two-Hand Control Safety Module (or other two-hand control systems designed to meet Type IIIC requirements per ISO 13851 (EN 574), and ISO 13849-1 category 4 requirements).

The microcontrollers in the STB buttons perform a continuous self-check: the emitter is continuously pulsed, and receiver response is checked accordingly by the microcontrollers. STB touch buttons are designed to immediately detect any internal component failure, go into lockout mode, and indicate the failure with a flashing red Fault LED.

### STB Series Touch Button LED Indicators

**Power On (green):** Steady ON when power is applied

**Output, Fault (green):** Steady ON when button is activated  
OFF when button is not activated  
Flashing when a fault condition is detected

# DUO-TOUCH® Run Bar with STB Buttons

## Appropriate Applications

The DUO-TOUCH Run Bar is intended for use as the initiation device in a two-hand control system for most powered machinery, when machine cycling is controlled by an individual.

The two-hand control system makes the operator a “hostage” while the hazard is present, thus limiting or preventing exposure of that operator to the hazard (see Warning at right). The two-hand control actuators must be located in a way that hazardous motion is completed or stopped before the operator can release one or both of the buttons and reach the hazard (see Separation Distance on page 6).

Two-hand control systems must meet requirements found in several U.S. and international standards. See the machine-specific standard (e.g., “C-level” in ISO/EN standards), ANSI NFPA 79, IEC 60204-1, ANSI B11.19, and ISO 13851 (EN 574) for complete information. Some of the requirements are:

- Simultaneous use of both hands (“synchronous action”): both buttons must be actuated within 500 ms of one another, even under single-fault conditions. Whenever this time is exceeded, both actuating devices must be released. This requirement reduces the possibility of intentional defeat and unintended initiation.
- Continuous actuation of both buttons during the hazardous situation. Releasing one or both buttons must cause the ceasing of the hazardous situation, and before the machine cycle can continue, both buttons must be released.
- When used in single-cycle or single-stroke mode, the machine control must provide an anti-repeat feature so that the operator must release the two-hand control actuators after each machine cycle, before a new cycle can be initiated.
- The actuating devices must be protected from accidental or unintended operation.
- When used for safeguarding, the interfacing must be at an appropriate level of safety circuit integrity as determined by a risk assessment. In the U.S., the required level of integration is Control Reliability (see ANSI B11.19). In many situations governed by ISO/IEC and EN regulations, the required integration for Type IIIC per ISO 13851 (EN 574) is Category 4 per ISO 13849-1 (EN 954-1).

To assist in complying with the above requirements, Banner Engineering recommends interfacing the STB buttons of the run bar with a DUO-TOUCH SG Two-Hand Control Module, such as the model AT-FM-10K, AT-.M-13A, or AT-.M-11KM, or other Type IIIC-compliant two-hand control system. See Warnings on front page and at right.



## WARNING . . . Point-of-Operation Guarding

When properly installed, a two-hand-control system using STB Touch Buttons as the actuating devices provides protection only for the hands of the machine operator. It may be necessary to install other guarding devices, such as safety light screens and/or hard guards, to protect personnel from hazardous machinery. **Failure to install appropriate point-of-operation guards on hazardous machinery can result in a dangerous condition which could lead to serious injury or death.**



## CAUTION . . . Hand Controls

The environment in which hand controls are installed must not adversely affect the means of actuation. **Severe contamination may cause slow response or false ON conditions of mechanical palm/push buttons or STB buttons. This may result in exposure to a hazard.**

# DUO-TOUCH® Run Bar with STB Buttons

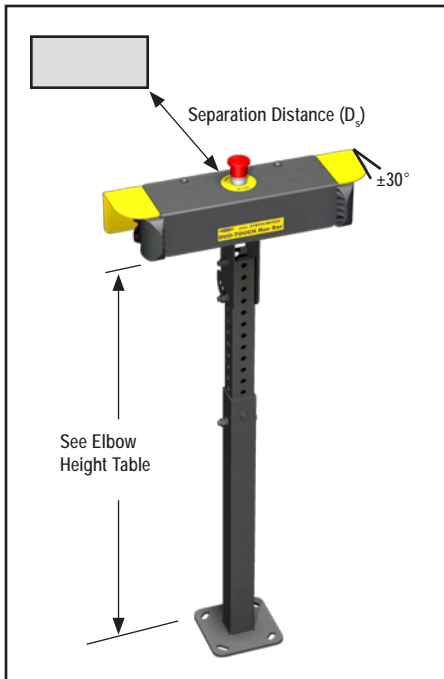

Figure 1. Run Bar location

## Mechanical Installation

Mount the DUO-TOUCH Run Bar in a way that maximizes its ergonomic design and minimizes the possibility of defeat. To minimize the possibility of defeat, ISO 13851 (EN 574) recommends that the hand controls be arranged on a horizontal (or nearly horizontal) surface, 1100 mm (43.3") above the floor. The Run Bar makes this installation easy.

To maximize ergonomics, ANSI B11.TR1 recommends that for light to normal work the position should be 50 to 100 mm (2" to 4") above or below elbow height. Elbow height should be determined and adjusted for each individual operator. Anthropometric tables provide a range for guidance (see ANSI B11.TR1 Annex A):

Elbow Height (to floor, without shoes)	5%	95%
	Male/Female	Male/Female
Inches	39.2" / 36.5"	45.4" / 42.3"
Millimeters	995 / 926 mm	1153 / 1074 mm

Tilting the run bar (using the bracket's multiple-hole adjustment) can allow for varying operator heights, while maintaining a neutral wrist position. This rotation should not exceed  $\pm 30^\circ$ , especially when an emergency stop button is mounted on the top of the run bar. Hand and wrist posture is considered to be neutral when the hand is neither flexed nor extended beyond about  $15^\circ$  of the normally relaxed position.

Per ANSI B11.TR1, the most desirable location for controls used by a standing operator is a position directly in front of the operator, and at a height between chest and waist level. Frequent reaches should nominally be made within 350 to 450 mm (14" to 18") from the center of the shoulder to the run bar. Only occasional reaches should be made within 550 to 650 mm (22" to 26"); avoid reaches farther than 650 mm (26"), see Figure 2.

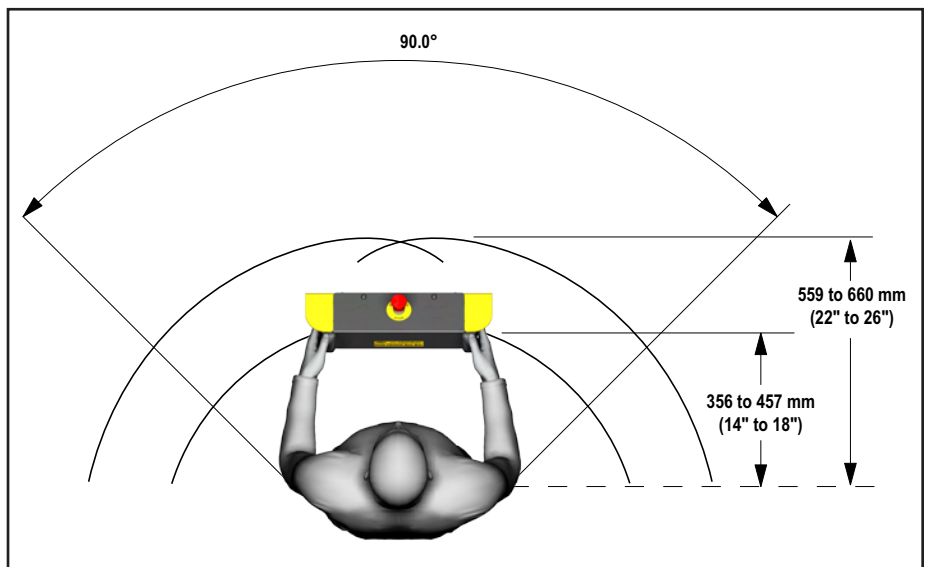

Figure 2. ANSI B11.TR1-recommended maximum-reach distances

# DUO-TOUCH® Run Bar with STB Buttons

## Example Separation Distance ( $D_s$ ) Calculation

The following example illustrates the use of the formula to calculate separation distance for a part-revolution clutch machine. This example uses 0.50 seconds as a typical value for  $T_s$  and 0.02 seconds for  $T_h$ :

$$\begin{aligned}K &= 63" \text{ per second,} \\T_s &= 0.50 \text{ seconds (measured by a} \\&\quad \text{stop-time measuring device)} \\T_r &= 0.035 \text{ seconds} \\T_h &= 0.02 \text{ seconds} \\D_s &= K \times (T_s + T_r + T_h) \\&= 63" (0.50 + 0.035 + 0.02) \\&= 35"\end{aligned}$$

In this example, both hand controls must be located no closer than 36" from the nearest hazard point.



### WARNING . . . Location of Touch Button Controls

Hand controls must be mounted a safe distance from moving machine parts, as determined by the appropriate standard. It must not be possible for non-qualified persons to relocate them. **Failure to establish and maintain the required safety distance could result in serious injury or death.**

## Separation Distance

Both hand controls must be located far enough away from the nearest hazard point that the operator cannot reach the hazard with a hand or other body part before the hazardous motion ceases. This is the "separation distance," and may be calculated as follows.

### For Part-Revolution Clutch Machinery

Where the machine and its controls allow the machine to stop motion during the hazardous portion of the machine cycle, use the following formula.

$$D_s = K \times (T_s + T_r + T_h)$$

### For Full-Revolution Clutch Machinery

Where the machine and its controls are designed to complete a full machine cycle, once activated, use the following formula:

$$D_s = K \times (T_m + T_r + T_h)$$

For both formulas:

$D_s$  = the separation distance in inches,

$K$  = 63" per second (the hand speed constant currently accepted by OSHA; see NOTE 1, below)

$T_s$  = the stop time (in seconds) of the machine, measured from the application of the "stop" signal to the final ceasing of all motion, including stop times of all relevant control elements, and measured at maximum machine velocity (see NOTE 2)

$T_r$  = the response time of the Safety Module as measured from the time a stop is signalled by either hand control. (Banner AT.. Series IIIc two-hand control Safety Modules approx. 0.035 seconds)

$T_h$  = the response time of the slowest hand control (from the time when a hand disengages that control until the switch opens; see NOTE 3)

$T_m$  = the maximum time (in seconds) the machine takes to cease all motion after it has been tripped. For full-revolution clutch presses with only one engaging point,  $T_m$  is equal to the time necessary for one and one-half revolutions of the crankshaft. For full-revolution clutch presses with more than one engaging point,  $T_m$  is calculated as follows:

$$T_m = (1/2 + 1/N) \times T_{cy}$$

where:

$N$  = number of clutch engaging points per revolution

$T_{cy}$  = time (in seconds) necessary to complete one revolution of the crankshaft

## NOTES:

1. The OSHA-recommended hand speed constant  $K$  has been determined by various studies, and although these studies indicate speeds of 63"/sec to over 100"/sec, they are not conclusive determinations. The employer should consider all factors, including the physical ability of the operator, when determining the value of  $K$  to be used.
2.  $T_s$  is usually measured by a stop-time measuring device. If the specified machine stop time is used, add at least 20% as a safety factor to account for brake system deterioration. If the stop-time of the two redundant machine control elements is unequal, the slower of the two times must be used for calculating the separation distance.
3.  $T_h$  is usually insignificant for purely mechanical switches. However,  $T_h$  should be considered for separation distance calculation when using electronic or electromechanical (i.e. powered) hand controls. In this example, STB response time = 0.02 seconds.

# DUO-TOUCH® Run Bar with STB Buttons



## CAUTION . . . Disconnect Power Before Wiring

Always disconnect all power from the DUO-TOUCH SG Safety Module and the machine being controlled before making any wire connections.

Electrical installation of hand controls, the DUO-TOUCH SG Safety Module, and the interconnection to the machine control must be made by qualified personnel and must comply with NEC (National Electrical Code), ANSI/NFPA 79 or IEC 60204-1, and all applicable local standards.

## Electrical Installation

Electrical installation of hand controls, the DUO-TOUCH SG Safety Module, and the interconnection to the machine control must be made by qualified personnel and must comply with NEC (National Electrical Code), ANSI/NFPA 79 or IEC 60204-1, and all applicable local standards.

Because the DUO-TOUCH Run Bar can interface with many types of two-hand control systems and machine controls, it is not possible to give exact wiring instructions here. The following guidelines are general in nature.

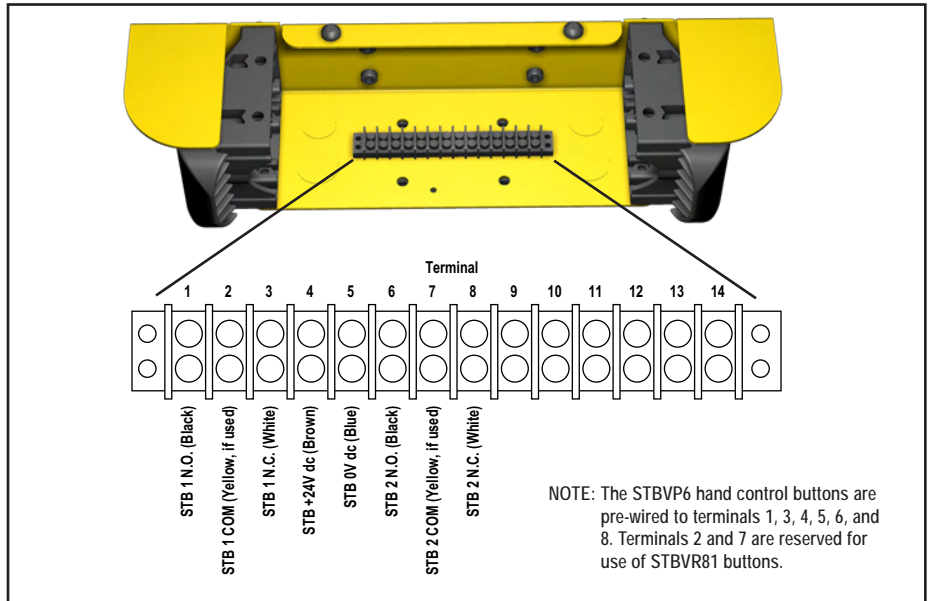

Figure 3. Terminal strip connections

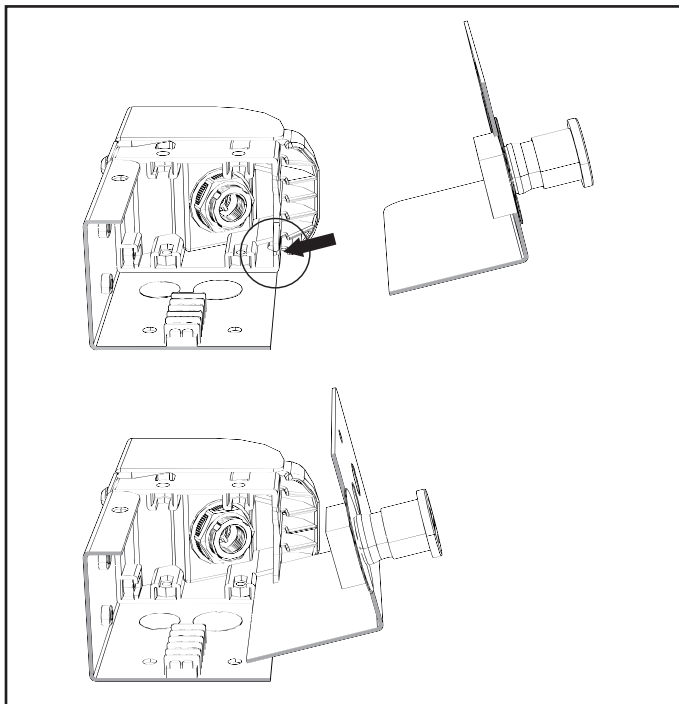
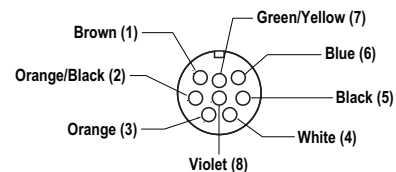

Figure 4. Use slots in run bar housing to hold cover for terminal connection

## 8-Pin Mini-Style Output QD Connector Male Face View



Mating Cable: QDS-8..C			SAE H1738-2 Alternate Color*
Pin	Color	Function	
1	Brown	+24V dc	Orange
2	Orange/Black	N.O. STB2	Blue
3	Orange	N.C. STB2	White/Black
4	White	N.C. STB1	Black
5	Black	N.O. STB1	White
6	Blue	0V dc	Red
7	Green/Yellow	Gnd/PE	Green
8	Violet	Not Connected (future use)	Red/Black

\* Listed as a customer courtesy. Verify suitability of these cables for each application.

Figure 5. 8-pin Mini-style QD connections

# DUO-TOUCH® Run Bar with STB Buttons

## Connection of STB Touch Buttons

To maintain a Type IIIC / Category 4 hookup, both the normally open and the normally closed outputs of each STB button must be connected to a two-hand control system or module (e.g., Banner model AT-FM-10K, AT-..M-13A, AT-..M-11KM or the Banner Safety Controller SC22-3) that meets the requirements listed on page 4 and monitors the STB outputs such that if they are not in a complementary state (one open/non-conducting and one closed/conducting) the system will lock out and prevent further operation until the fault is repaired.

The +24V dc supply power for the STB buttons must be the same supply that powers the two-hand control system or module. If a DUO-TOUCH SG safety module is used, use terminals Z1 and Z2 for supply voltage for the STB buttons.

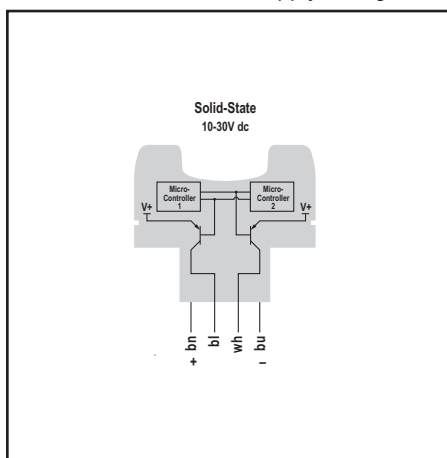

Figure 6. STB Touch Button block diagram

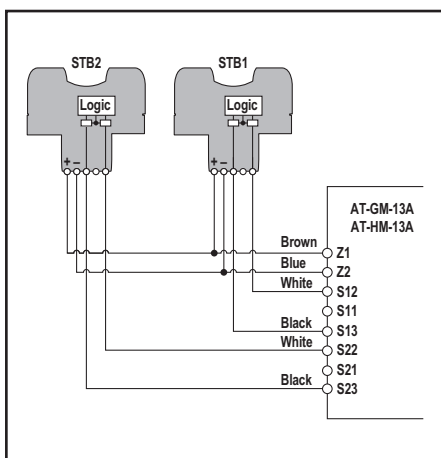

Figure 7. Hookup to two STB Touch Buttons with PNP (sourcing) outputs

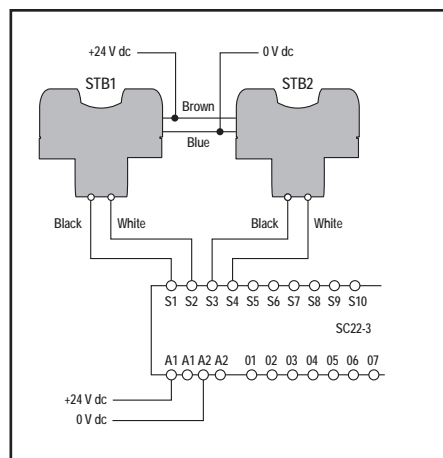

Figure 8. Hookup of two STB Touch Buttons to the Banner Safety Controller

## Connection of Emergency Stop Button

For models with an E-stop button, connection of the E-stop button is made at the screw terminals on the contact element mounted on the mounting adapter.

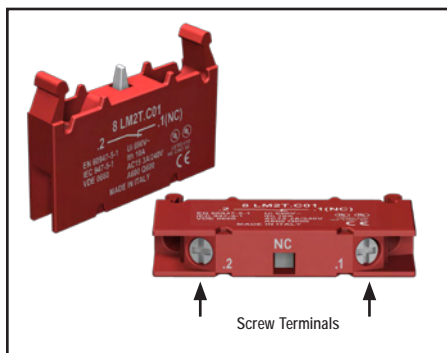

Figure 9. E-stop wiring terminals

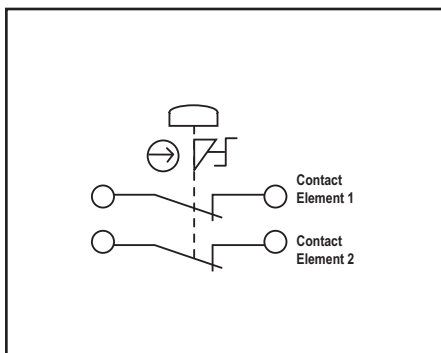

Figure 10. E-stop wiring diagram



**WARNING . . .**  
**Multiple E-Stop**  
**Switches**

Whenever two or more E-stop switches are connected to the same E-stop safety module, the contacts of both switches must be connected together in series. This series combination is then wired to the respective safety module input. Never connect the contacts of multiple E-stop switches in parallel to the E-stop safety module inputs; this defeats the switch contact monitoring ability of the safety module, and creates an unsafe condition which could result in serious injury or death.

# DUO-TOUCH® Run Bar with STB Buttons



## **WARNING. . . Do Not Use System Until Checkouts Are Verified**

If all of the described checks cannot be verified, **the two-hand control system must not be used until the problem has been corrected.** Injury or death to personnel may result from attempts to use the machine under such conditions.

## Checkout Procedures

Checkout procedures are dependent on what two-hand control system or module is interfaced with the DUO-TOUCH Run Bar. At minimum, the procedure should include the requirements on page 4 and the following:

1. Verify that all point-of-operation guards are in place and operating properly.
2. Verify that the two actuating devices must be simultaneously engaged to actuate the machine (within ½ second).
3. **For single-cycle machines:** Verify that maintained engagement of the two actuating devices results in only one machine cycle.
4. **For part-revolution clutch machines:** Verify that release of either actuating device results in the immediate arrest of the machine motion.
5. Verify that the distance from each actuating device to the closest hazard point is not closer than the calculated safety distance (see page 6).

Checkout procedures should be accomplished at installation (i.e., commissioning) and at periodic intervals, such as:

- **Daily Checkout**, to be performed at every power-up, shift change, and machine setup change, and to be performed by a designated person, appointed and identified in writing by the employer.
- **Semi-Annual Checkout**, to be performed at six-month intervals. This semi-annual checkout must be performed by a qualified person.\* A copy of test results should be kept on or near the machine.

\* **Qualified person:** A person who, by possession of a recognized degree or certificate of professional training, or who, by extensive knowledge, training, and experience, has successfully demonstrated the ability to solve problems relating to the installation, maintenance and use of the Two-Hand Control System.

## Repairs



**NOTE:** Do not attempt any repairs to the STB Series touch buttons. They contain no field-replaceable components. Return them to the factory for warranty repair or replacement.

If it ever becomes necessary to return an STB Series touch button to the factory, please do the following:

1. Contact the Banner Factory Application Engineering Group at the address or at the numbers listed at the bottom of the back page. They will attempt to troubleshoot the system from your description of the problem. If they conclude that a component is defective, they will issue an RMA (Return Merchandise Authorization) number for your paperwork, and give you the proper shipping address.
2. Pack the components carefully. Damage which occurs in return shipping is not covered by warranty.

# DUO-TOUCH® Run Bar with STB Buttons

## Specifications

Supply Voltage and Current	10 to 30V dc Power consumption: approx. 1.8W @ 24V dc (with no output load), for each STB
Supply Protection Circuitry	Protected against transient voltages and reverse polarity
Output Configuration	Complementary PNP (sourcing) open-collector transistors
Output Rating	Maximum load: 150 mA On-state saturation voltage: $\leq 15V$ @ full load Off-state leakage current: $< 1 \mu A$
Output Protection Circuitry	Protected against false pulse on power-up; overload and short-circuit protection.
Output Response Time	20 milliseconds ON/OFF
STB Indicators	2 green LED indicators: Power: ON – power applied Output/fault: ON – button is activated OFF – button is deactivated Flashing – internal fault or blocked button on power-up detected
Construction	STB Buttons: Totally encapsulated, non-metallic enclosure; black polyetherimide yoke housing (see Application Note below); fiber-reinforced polyester base; electronics fully epoxy-encapsulated. E-Stop Button: Polyamide red button with metal base. Run Bar Housing: 13 ga (0.090") cold rolled steel with powder coat paint; polypropylene copolymer STB mount.
Environmental Rating	STBVP6-RB1 Run Bar Models meet IP20 STBVP6-RB2 Run Bar Models meet IP65
Connections	Models STBVP6-RB1/-RB2 and -RB1E02/-RB2E02: Terminal strip connections inside run bar housing (STBs are pre-wired). E-stop button and EZ-LIGHT indicator (if used) are wired separately. Models STBVP6-RB1Q8/-RB2Q8: 8-pin Mini-style quick-disconnect fitting
Ambient Light Immunity	Up to 100,000 lux
EMI/RFI Immunity	Immune to EMI and RFI noise sources, per IEC 947-5-2.
Operating Conditions	Temperature: 0° to +50° C (+32° to +122° F) Maximum relative humidity: 90% @ +50° C (non-condensing)
Application Notes	The STB's polyetherimide upper housing will become brittle with prolonged exposure to outdoor sunlight. Window glass effectively filters longer wavelength ultraviolet light and provides excellent protection from sunlight. Avoid contact with strong alkalis, hydrocarbons and fuels. Clean periodically using mild soap solution and a soft cloth. (Polycarbonate STB models are also available for use with the Run Bar; contact Factory for assistance.)
Certifications	STB Buttons:   us      STBVP6-RB2...Run Bars: 

# DUO-TOUCH® Run Bar with STB Buttons

## Dimensions

### STBVP6-RB1 Models

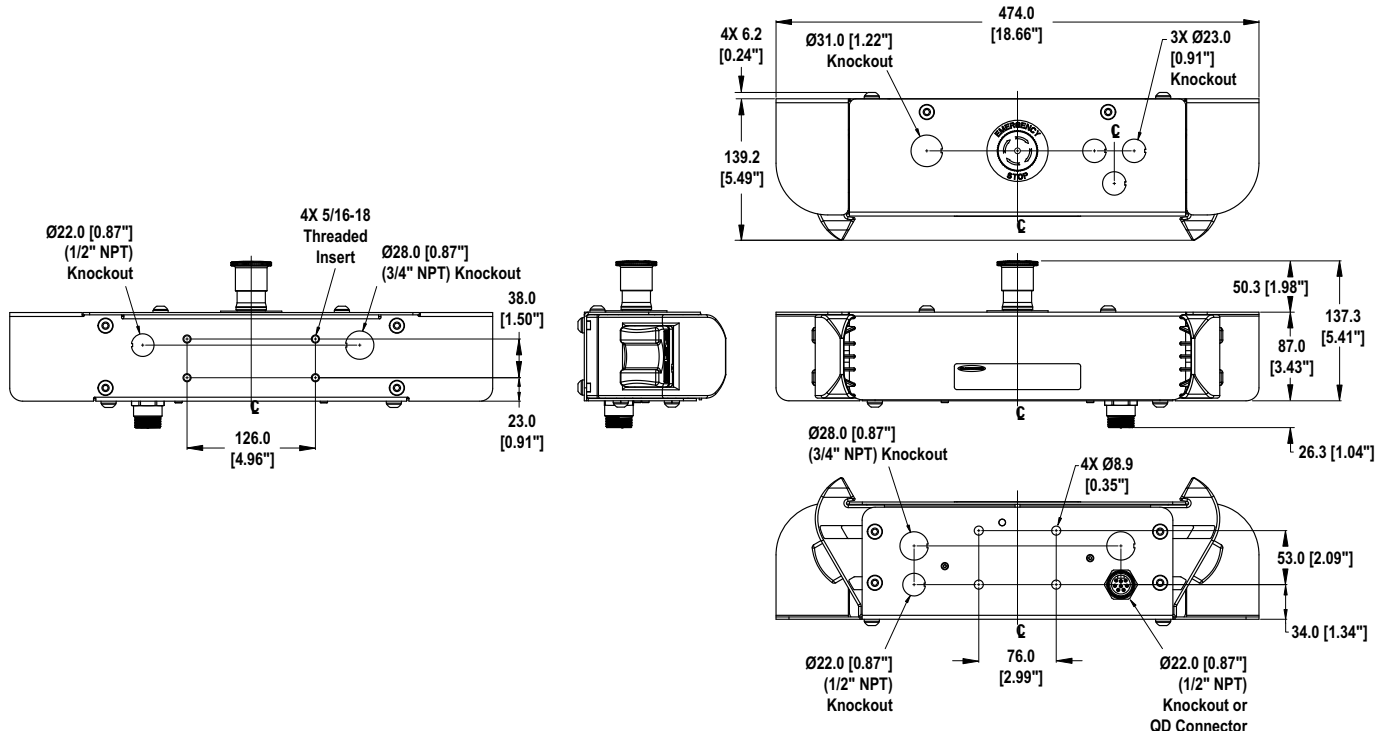



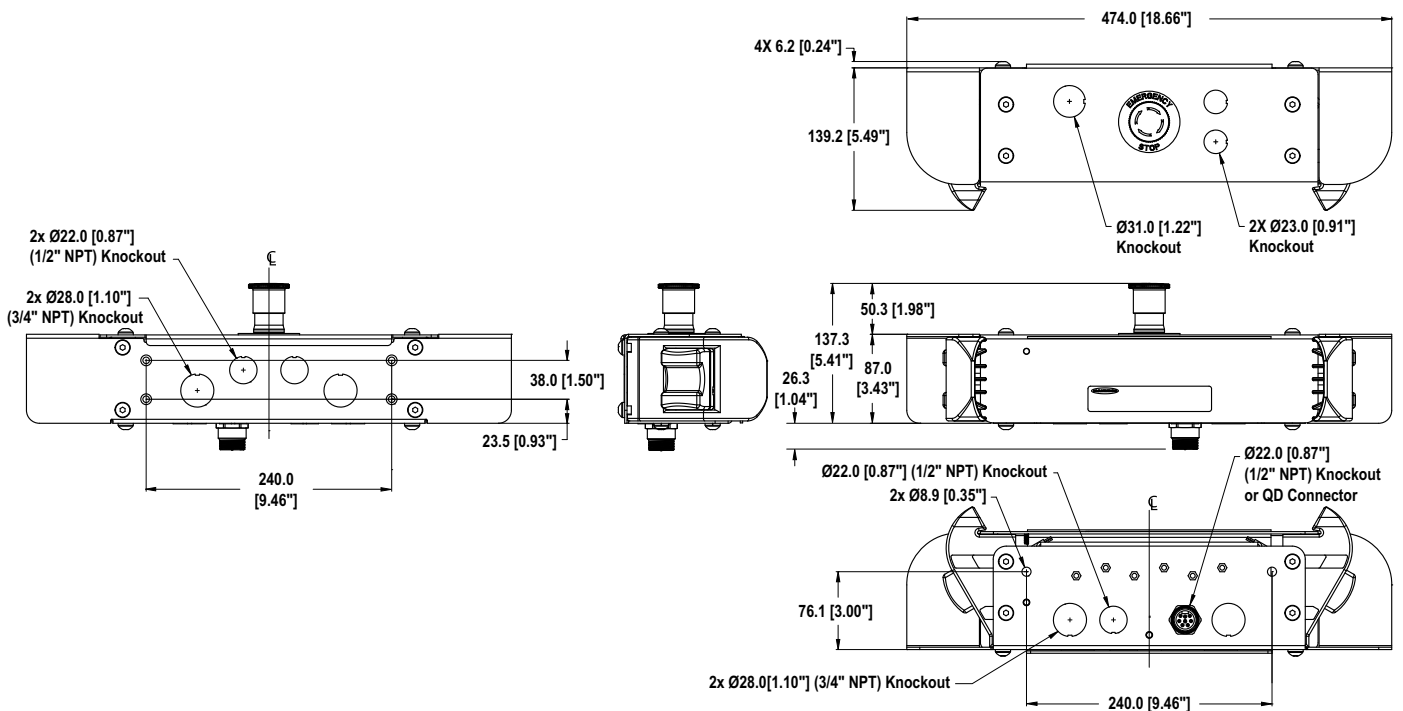



### STBVP6-RB2 Models



# DUO-TOUCH® Run Bar with STB Buttons

## Accessories

### Mounting Brackets

Used on STBVP6-RB1 Run Bars		
Model	Description	Product
STBA-RB1-MB1	<ul style="list-style-type: none"> <li>• Pair of wall-mount brackets; run bar “hangs” on vertical surface</li> <li>• Slotted holes for vertical adjustment</li> <li>• Made of 12 ga cold-rolled steel with black powdercoat paint</li> </ul>	
STBA-RB1-MB2	<ul style="list-style-type: none"> <li>• Universal-mount bracket; allows run bar to mount to vertical stand or surface</li> <li>• Slotted holes for adjustment</li> <li>• Made of 12 ga cold-rolled steel with black powdercoat paint</li> </ul>	
STBA-RB1-MB3	<ul style="list-style-type: none"> <li>• Swivel-mount bracket; mounts to telescoping stands below</li> <li>• Holes for radial adjustment, 0°–30° in 10° increments</li> <li>• Made of 12 ga cold-rolled steel with black powdercoat paint</li> <li>• Replacement part; included with telescoping stands STBA-RB1-S1 and STBA-RB1-S2</li> </ul>	
Used on STBVP6-RB2 Run Bars		
Model	Description	Product
STBA-RB2-MB1	<ul style="list-style-type: none"> <li>• Pair of wall-mount brackets; run bar “hangs” on vertical surface</li> <li>• Slotted holes for vertical adjustment</li> <li>• Made of 12 ga cold-rolled steel with black powdercoat paint</li> </ul>	
STBA-RB2-MB2	<ul style="list-style-type: none"> <li>• Universal-mount bracket; allows run bar to mount to vertical stand or surface</li> <li>• Slotted holes for adjustment</li> <li>• Made of 12 ga cold-rolled steel with black powdercoat paint</li> </ul>	
STBA-RB2-MB3	<ul style="list-style-type: none"> <li>• Swivel-mount bracket; mounts to telescoping stands below</li> <li>• Holes for radial adjustment, 0°–30° in 10° increments</li> <li>• Made of 12 ga cold-rolled steel with black powdercoat paint</li> <li>• Replacement part; included with telescoping stands STBA-RB2-S1 and STBA-RB2-S2</li> </ul>	

### Telescoping Stands

Model	Description	Product
STBA-RB1-S1	<ul style="list-style-type: none"> <li>• Floor-mounted, telescoping stand; locates touch buttons 800 to 1232 mm (31.5" to 48.5") above the floor surface</li> <li>• 150 mm (5.9") square stationary floor base with 4 mounting holes in corners</li> <li>• Telescoping square tubes made of 12 ga cold-rolled steel; base 1/4" cold-rolled steel; black powdercoat paint</li> </ul>	
STBA-RB2-S1	<ul style="list-style-type: none"> <li>• STBVP6-RB1-S1 Includes swivel-mount bracket STBA-RB1-MB3 to mount STBVP6-RB1... Run Bars</li> <li>• STBVP6-RB2-S1 Includes swivel-mount bracket STBA-RB2-MB3 to mount STBVP6-RB2... Run Bars</li> <li>• See datasheet 135635 for more information on STBA-RB1-S1</li> <li>• See datasheet 145295 for more information on STBA-RB2-S1</li> </ul>	

# DUO-TOUCH® Run Bar with STB Buttons

## Accessories, continued

### Telescoping Stands, continued

STBA-RB1-S2	<ul style="list-style-type: none"> <li>• Free-standing, telescoping stand; locates touch buttons 800 to 1232 mm (31.5" to 48.5") above the floor surface</li> <li>• 610 x 610 mm (24" x 24") movable H-shaped floor base with mounting holes 560 mm (22") apart</li> <li>• Telescoping square tubes made of 12 ga cold-rolled steel; U-channel feet are 2"W x 1"H x 1/8" thick cold-rolled steel; black powdercoat paint</li> </ul>	
STBA-RB2-S2	<ul style="list-style-type: none"> <li>• STBVP6-RB1-S2 includes swivel-mount bracket STBA-RB1-M3 to mount STBVP6-RB1... Run Bars</li> <li>• STBVP6-RB2-S2 includes swivel-mount bracket STBA-RB2-M3 to mount STBVP6-RB2... Run Bars</li> <li>• See datasheet 135635 for more information on STBA-RB1-S2</li> <li>• See datasheet 145295 for more information on STBA-RB2-S2</li> </ul>	

### EZ-LIGHT for Two-Hand Control

Model	Description	Product
K50LGRYB11P	<ul style="list-style-type: none"> <li>• EZ-LIGHT for Two-Hand Control</li> <li>• Four-color indication: red, blue, green, and yellow</li> <li>• See data sheet 134100 for more information</li> </ul>	
T30GRYB11P		

### EZ-LIGHT Wiring Table

LED Function	Brown Wire	Gray Wire	Black Wire	White Wire	Typical Function
Red ON	+V dc	—	—	—	Stop and/or Not Ready
Blue ON	+V dc	+V dc	—	—	Stopped, but Ready/Enabled
Green ON	+V dc	+V dc	+V dc	—	Go
Yellow ON	+V dc	+V dc	+V dc	+V dc	Mute Condition
Red Flashing	Any other hookup combination				Abnormal State

#### NOTES:

- Blue wire connected to 0V dc
- Supply Voltage and Current = 10 to 30V dc, 60 mA max.

N.C. = Normally Closed, N.O. = Normally Open

### DUO-TOUCH® SG Two-Hand Control Modules, STB Compatible

Model	Supply Voltage	Inputs	Safety Outputs	Output Rating	Auxiliary Outputs	Muting	Terminals
AT-FM-10K	24V ac/dc	2 STB	2 N.O.	6 amps	—	—	Removable
AT-GM-13A	115V ac/24V dc		4 N.O.		—		
AT-HM-13A	230V ac/24V dc	2 STB and Muting	2 N.O.		1 NPN, 1 PNP, and 1 N.C.	—	
AT-GM-11KM	115V ac/24V dc					Yes	
AT-HM-11KM	230V ac/24V dc						

# DUO-TOUCH® Run Bar with STB Buttons

## Quick-Disconnect (QD) Cables

SC22-3 Safety Controller, STB Compatible

Model	Removable Terminal Type	Safety Outputs	Supply Voltage	Output Rating	Aux. Outputs	Inputs	Communication Protocol	Muting	
SC22-3-SU1	Screw	3 PNP (dual)	24V dc	4.5 amps	10 PNP	22 (up to 10 STBs)	—	Yes	
SC22-3-CU1	Clamp								
SC22-3-S	Screw								
SC22-3-C	Clamp								
SC22-3E-SU1	Screw			3.5 amps			EtherNet/IP & Modbus TCP		
SC22-3E-CU1	Clamp								
SC22-3E-S	Screw								EtherNet/IP & Modbus TCP
SC22-3E-C	Clamp								

Power and Input/Output Cordsets\*

Model Number	Length	Termination	Wire	Banner Cable Pinout/Color Code	SAE H1738-2** Pinout/Color Code	Cordset Connector		
Input/Output Cordsets			20 gauge	Pin	Color	Pin	Color	(female face view)
QDS-815C QDS-825C QDS-850C	5 m (15') 8 m (25') 15 m (50')	8-pin Mini-style Female connector on one end; cut-to-length.		1	Bn	1	Or	
			2	Or/Bk	2	Bu		
			3	Or	3	Wh/Bk		
			4	Wh	4	Bk		
			5	Bk	5	Wh		
			6	Bu	6	Rd		
			7	Gn/Ye	7	Gn		
			8	Vi	8	Rd/Bk		

\*Unterminated bulk cable available (UTB-3...C, UTB-5...C, UTB-8...C) in 25', 50', 100', and 250' lengths. See below.

\*\*The SAE H1738-2 pin assignment and color codes are listed as a customer courtesy. The user must verify suitability of these cables for each application.



Unterminated Bulk Cable

Model Number	Length	Wire	Description
UTB-825C UTB-850C UTB-8100C UTB-8250C	8 m (25') 15 m (50') 30 m (100') 75 m (250')	20 gauge	8-conductor, unterminated bulk cable







# DUO-TOUCH® Run Bar with STB Buttons

## Replacement Parts

### STB Self-Checking Touch Buttons

Models	Description	Product
STBVP6-78974	<ul style="list-style-type: none"> <li>• Solid-state complementary PNP outputs</li> <li>• Polyetherimide upper housing</li> <li>• 300 mm (12"), 4-wire PVC-jacketed cable</li> </ul>  	

### E-Stop Push-Button Components

Models	Description	Product
SSA-EBM-02L	Metal E-stop button with 2 N.C. contacts	
8-LM2T-B6644	22.5 mm metal button (mounting adapter sold separately). Twist to release, mechanical latching ISO 13850 (EN 418) compliant. Diameter 40 mm (without mounting adapter).	
8-LM2T-AU120	Metal mounting adapter for metal button	
8-LM2T-C01	Normally closed (NC) positively driven contact element. Direct (positive) opening operation per IEC/EN 60947-5-1.	
8-LM2T-C10	Normally open (NO) auxiliary contact element	
8-LM2T-AU115	60 mm diameter, non-adhesive plastic legend with "Emergency Stop" inscription	

### Telescoping Stand Component

Models	Description	Product
STBA-RB1-SGP	Quick-release gravity pin to allow rotation of Run Bar on telescoping stand. (Can also be used for quick height adjustment of stand.)	