

Original Instructions



Features

- Diverse-redundant microcontrollers
- Monitors two Banner STB Self-Checking Optical Touch Buttons, or two mechanical push buttons
- Two redundant, forced-guided (mechanically linked) output contacts rated at 6 A
- Feedback input monitors external machine control elements
- 5 indicator LEDs for Power, Fault, Input 1, Input 2 and Output
- 24V ac/dc operation
- DIN-rail-mountable 22.5 mm-wide housing with removable terminal blocks
- 500 ms (max.) simultaneity requirement for touch-/push button operation

Overview

A DUO-TOUCH SG Two-Hand Control Safety Module (the "Safety Module") may be used with:

- Two Banner STB Self-Checking Optical Touch Buttons, each with one normally open and one normally closed relay output contact, or
- Two Banner STB Self-Checking Optical Touch Buttons, each with two current-sourcing PNP outputs, or
- Two electro-mechanical push buttons, each with one normally open and one normally closed contact (Form C contact)

If the machine operator removes one or both hands from the actuating device(s), the Duo-Touch SG relays de-energize, causing the output contacts to open. The relays will not re-energize until both actuating devices are deactivated and then simultaneously reactivated.

The Duo-Touch SG Two-Hand Control Kit system complies with:

- Two-hand control and Control Reliability requirements per OSHA 29CFR1910.217, ANSI NFPA 79, ANSI B11.19, and ANSI/RIA R15.06,
- Type IIIC requirements of ISO 13851 (EN 574) Safety of Machinery – Two-Hand Control Devices, and
- Safety-related applications up to Category 4 PL e, per EN ISO 13849-1 and SIL3 per IEC 61508 and IEC 62061.

The Safety Module's output signal consists of two sets of redundant, forced-guided (mechanically linked) contacts (see Figure 4). Circuitry within the Safety Module monitors these internal contacts and prevents an output signal from occurring if a fault is detected. A feedback loop is offered for monitoring the status of the machine control elements.



WARNING ...

Point-of-Operation Guarding

When properly installed, the DUO-TOUCH SG Two-Hand Control Safety Module provides protection only for the hands of the machine operator. It may be necessary to install additional safeguarding, such as safety light screens, additional two-hand controls, and/or hard guards, to protect all individuals from hazardous machinery.

Failure to properly guard hazardous machinery can result in a dangerous condition which could lead to serious injury or death.

Important ... read this page before proceeding!

The user is responsible for satisfying all local, state, and national laws, rules, codes, and regulations relating to the use of this product and its application. Banner Engineering Corp. has made every effort to provide complete application, installation, operation, and maintenance instructions.

Please direct any questions regarding the use or installation of this product to the factory applications department at the telephone numbers or address shown on back cover.

The user is responsible for making sure that all machine operators, maintenance personnel, electricians, and supervisors are thoroughly familiar with and understand all instructions regarding the installation, maintenance, and use of this product, and with the machinery it controls. The user and any personnel involved with the installation and use of this product must be thoroughly familiar with all applicable standards, some of which are listed below. Banner Engineering Corp. makes no claim regarding a specific recommendation of any organization, the accuracy or effectiveness of any information provided, or the appropriateness of the provided information for a specific application.

Applicable U. S. Standards

ANSI B11 Standards for Machine Tools "Safety Requirements for the Construction, Care and Use"
Contact: Safety Director
AMT – The Association for Manufacturing Technology
7901 Westpark Drive
McLean, VA 22102
Tel.: 703-893-2900

ANSI NFPA79 "Electrical Standard for Industrial Machinery"
Contact: National Fire Protection Association
1 Batterymarch Park, P.O. Box 9101
Quincy, MA 02269-9101
Tel.: 800-344-3555

ANSI/RIA R15.06 "Safety Requirements for Industrial Robots and Robot Systems"
Contact: Robotic Industries Association
900 Victors Way, P.O. Box 3724
Ann Arbor, MI 48106
Tel.: 734-994-6088

Applicable European Standards

ISO 12100-1 & -2 (EN292-1 & -2) Safety of Machinery – Basic Concepts, General Principles for Design, Part 1: Basic Terminology, Methodology", "Part 2: Technical Principles and Specifications"
IEC/EN60204-1 "Electrical Equipment of Machines: Part 1: General Requirements"
IEC 61508 "Functional Safety of Electrical/Electronic/Programmable Electronic Safety-Related Systems"
IEC 62061 "Safety of Machinery – Functional Safety of Safety Related Electrical, Electronic, and Programmable Electronic Safety-Related Systems"
EN ISO13849-1 "Safety of Machinery – Safety Related Parts of Control Systems"
ISO13855 (EN999) "Safety of Machinery – The Positioning of Protective Equipment"
ISO13851 (EN574) "Safety of Machinery – Two-Hand Control Devices"
Also, request a type "C" standard for your specific machinery.
Contact: Global Engineering Documents
15 Inverness Way East
Englewood, CO 80112-5704
Tel.: 800-854-7179

Certificate of Adequacy

This Safety Module data sheet (p/n 64137, revision E) satisfies the requirements of Machinery Directive 2006/42/EC, Section 1.7.4 — instructions.

DUO-TOUCH® SG – Model AT-FM-10K Two-Hand Control Module

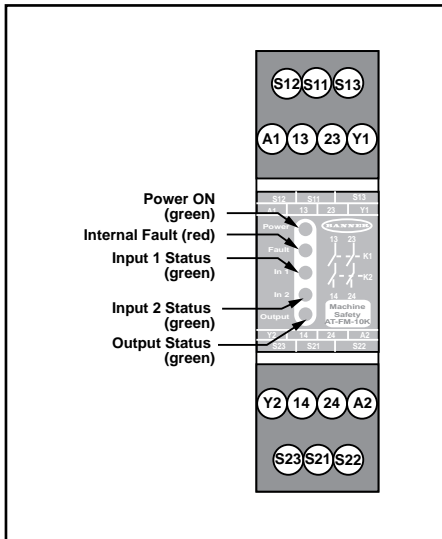

Figure 1. Status indicators and terminal locations

⚠ CAUTION ... Not an Anti-Repeat Control Device

Anti-repeat control is not a function of the AT-FM-10K Two-Hand Control Safety Module. The user of this device must provide a suitable means of accomplishing anti-repeat control for any single-stroke or single-cycle machine.

DUO-TOUCH SG Safety Module LED Indicators (see Figure 1)

Power On: ON when power is applied

Fault: ON if simultaneity is not met or external wiring fault
Flashing when internal fault condition is detected

Input 1 (2) Status: ON if touch button is activated
OFF when button is not activated
Flashing if external wiring fault is detected

Output Status: ON if both relays (K1 and K2) are energized
Flashing if feedback error has occurred

The DUO-TOUCH SG Two-Hand Control Safety Module may be used as an initiation device for most powered machinery when machine cycling is controlled by a machine operator.

Using a two-hand control system makes the operator a “hostage” while the hazard is present, thus limiting or preventing exposure to the hazard. The two-hand control actuators must be located in a way that hazardous motion is completed or stopped before the operator can release one or both of the buttons and reach the hazard (see Separation Distance, page 5).

The Safety Module’s safety inputs are used to monitor the actuation of the hand controls to comply with the functionality of Type III requirements of IEC60204-1 and ISO 13851 (Type IIIa/Cat 4) and the requirements of ANSI NFPA79 and ANSI B11.19 for two-hand control, which include (also see Figure 2):

- Concurrent (simultaneous) actuation by both hands within a 500 ms time frame
- Where this time limit is exceeded, a requirement that both hand controls must be released before operation is initiated
- Continuous actuation during hazardous condition
- Cessation of hazardous condition if either hand control was released
- Release and re-actuation of both hand controls to re-initiate the hazardous motion or condition (i.e., “anti-tie down”)
- The appropriate performance level of the safety-related function (e.g., Control Reliability, Category/Performance Level, or SIL) as determined by a risk assessment or the applicable regulation and standards (see page 2).

In addition, the Safety Module logic will not permit the safety outputs to turn ON when power is initially supplied and if the hand controls (actuators) are in their Run state (e.g. both actuators tie-down). The hand controls must change to their Stop state and return to the Run state before the safety outputs can turn ON.

The actuating devices must be protected from accidental or unintended operation. This can be accomplished by their mounting position and/or through the use of protective shields such as rings, guards or shields; see Figure 3.

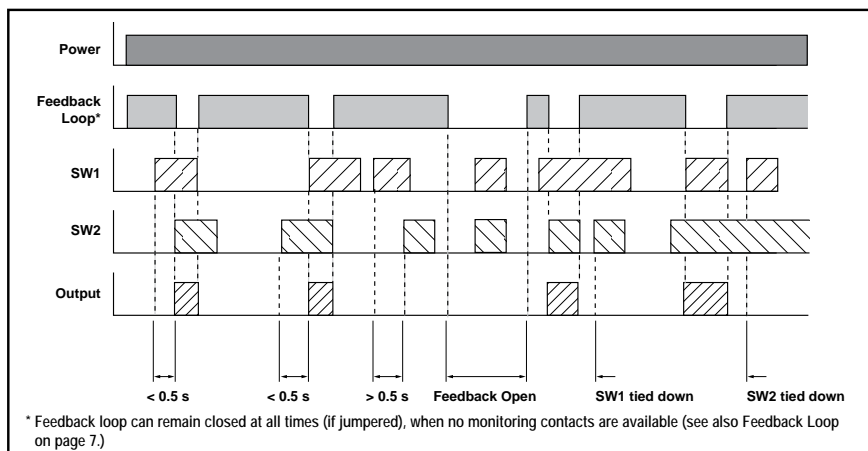

Figure 2. Timing diagram

When used on Part-Revolution Clutched Machinery that can be stopped at any point during the cycle, the Safety Module can be used for the following function types: “inch” (jog), “single-stroke,” or “continuous” (run). When used on Full-Revolution Clutched Machinery (that can not be stopped until the end of the cycle), the Safety Module is used to *initiate* the cycle and is known as a “two-hand trip device.” In either situation, the hand controls must be safely located and protected from false operation (see Mechanical Installation on page 4 and Separation Distance on page 5) and the Safety Module must be appropriately interfaced to the machine (see Electrical Installation on page 6).

DUO-TOUCH[®] SG – Model AT-FM-10K Two-Hand Control Module

When used in single-cycle or single-stroke mode, the machine control must provide an anti-repeat feature so that the operator must release the two-hand control actuators after each machine cycle, before a new cycle can be initiated (see Caution).

NOTE: Two-hand control and two-hand trip safeguarding protect *only the operator's hands*. Additional safeguarding (e.g., additional two-hand controls) may be required. Refer to the relevant standards for additional requirements.

Mechanical Installation

The Safety Module must be installed inside an enclosure rated NEMA 3 (IEC IP54), or better. It is not designed for exposed wiring. Dimensions of the Safety Module are shown in Figure 6. The Module mounts directly onto a standard 35 mm DIN rail.

Heat Dissipation Considerations

For reliable operation, the user must ensure that the operating specifications are not exceeded. The enclosure must provide adequate heat dissipation, so that the air closely surrounding the Module does not exceed the maximum operating temperature stated in the Specifications (page 11). Methods to reduce heat build-up include venting, forced airflow (e.g., exhaust fans), adequate enclosure exterior surface area, and spacing between modules and other sources of heat.

Installation of Hand Controls

Each actuating device requires a normally open and a normally closed (e.g., Form C or SPDT) hard contact, each capable of reliably conducting 25 mA at 24V dc (nominal). For complementary PNP operation, model STBVP.. touch buttons must be used to ensure proper functionality.

Standards require that the actuating devices be mounted to protect them from accidental or unintentional operation. Use shields, covers, rings, collars, dividers, or similar protection to prevent accidental switch actuation and to discourage use of forearms or elbows. European standard ISO13851 includes a detailed discussion of approaches to protection of hand controls.

The installation of the hand controls must also consider:

- Failure modes that would result in a short circuit, a broken spring(s), mechanical seizure, etc. that would result in not detecting the release of a hand control.
- Severe contamination or other environmental influences that may cause slow response when released or false ON condition of the hand control(s), e.g., sticking of a mechanical linkage.

The hand controls must be arranged far enough apart so that the operator cannot operate both hand controls by the use of one arm. Typically, this distance is not less than 550 mm/21.7" in a straight line, but using guards or alternate mounting arrangement can allow shorter distances, per ISO13851 (EN574). This standard also recommends that the hand controls be arranged on a horizontal (or nearly horizontal) surface that is 1,100 mm/43.3" above the floor for ergonomic purposes.

When installing the hand controls, consider ergonomic principles, in order to avoid unnecessary user fatigue. See ISO13851 (EN574) Two-Hand Control, ANSI B11.TR1–Ergonomic Guidelines, and EN894–Safety of Machinery–Ergonomic Requirements–Control Actuators for further information.

Figure 3 shows two examples for mounting Banner's STB Touch Buttons. When mounted on top of the control bar, the protective field covers should be in place, as shown. For added protection, mount the devices sideways under and behind a protective hood, rather than on top of the bar, leaving the field covers off. This side mount reduces the possibility of the operator easily positioning and leaving an object in the path of the beam, intentionally bypassing the safeguard.

⚠ CAUTION . . . Install Hand Controls to Prevent Accidental Actuation

Total protection for the two-hand control system from "defeat" is not possible. However, the user is required by OSHA regulations to arrange and protect hand controls to minimize possibility of defeat or accidental actuation.

⚠ CAUTION . . . Hand Controls

The environment in which hand controls are installed must not adversely affect the means of actuation. Severe contamination or other environmental influences may cause slow response or false ON conditions of mechanical or ergonomic buttons. This may result in exposure to a hazard.

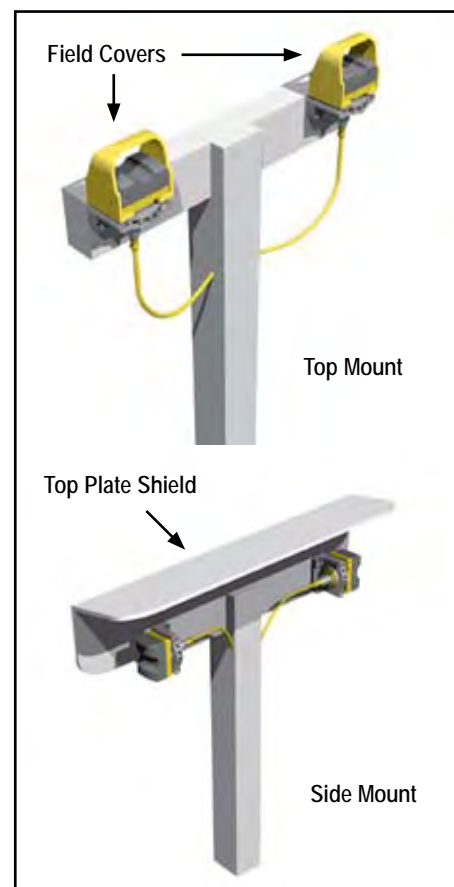

Figure 3. Install activation devices so that they are protected to prevent defeat or inadvertent actuation (Banner STB Touch Buttons shown)

DUO-TOUCH® SG – Model AT-FM-10K Two-Hand Control Module

Example Separation Distance (D_S) Calculation

The following example illustrates the use of the formula to calculate separation distance for a part-revolution clutch machine. This example uses 0.50 seconds as a typical value for T_S and 0.035 seconds for T_H :

$$\begin{aligned} K &= 63" \text{ per second,} \\ T_S &= 0.50 \text{ seconds (measured by a} \\ &\quad \text{stop-time measuring device)} \\ T_R &= 0.035 \text{ seconds} \\ T_H &= 0.035 \text{ seconds} \\ D_S &= K \times (T_S + T_R + T_H) \\ &= 63" (0.50 + 0.035 + 0.035) \\ &= 36" \end{aligned}$$

In this example, both hand controls must be located no closer than 36" from the nearest hazard point.



WARNING ... Location of Touch Button Controls

Hand controls must be mounted a safe distance from moving machine parts, as determined by the appropriate standard. It must not be possible for the operator or other non-qualified persons to relocate them. Failure to establish and maintain the required safety distance could result in serious injury or death.

NOTES:

1. The OSHA-recommended hand speed constant K has been determined by various studies, and although these studies indicate speeds of 63"/sec to over 100"/sec, they are not conclusive determinations. The employer should consider all factors, including the physical ability of the operator, when determining the value of K to be used.
2. T_S is usually measured by a stop-time measuring device. If the specified machine stop time is used, add at least 20% as a safety factor to account for brake system deterioration. If the stop-time of the two redundant machine control elements is unequal, the slower of the two times must be used for calculating the separation distance.
3. T_H is usually insignificant for purely mechanical switches. However, T_H should be considered for separation distance calculation when using electronic or electromechanical (i.e. powered) hand controls. In this example, STB response time = 0.035 seconds.

Requirements for Multiple-Operator Control

Standards have specified several conditions for situations where multiple operators work together to control one machine:

- Each operator must actuate his/her own pair of actuating devices, with all pairs of actuators active at one time, in order to initiate a machine cycle; the machine may not be allowed to operate until this condition is true.
- The actuators all must be released between cycles.
- The actuation and de-actuation of all workstations requiring two-hand control must be supervisable and must provide indication.
- The clutch/brake control system must be designed so that the clutch cannot be actuated if all the operating workstations are bypassed.

It is the responsibility of the user to determine if this two-hand control system can be interfaced to the machine in a manner to satisfy all existing requirements for multiple-operator control.

Separation Distance

Both hand controls must be located far enough away from the nearest hazard point that the operator cannot reach the hazard with a hand or other body part before the hazardous motion ceases. This is the "separation distance," and may be calculated as follows:

For Part-Revolution Clutch Machinery

Where the machine and its controls allow the machine to stop motion during the hazardous portion of the machine cycle, use the following formula:

$$D_S = K \times (T_S + T_R + T_H)$$

For Full-Revolution Clutch Machinery

Where the machine and its controls are designed to complete a full machine cycle, once activated, use the following formula:

$$D_S = K \times (T_m + T_R + T_H)$$

For both formulas:

- D_S = the separation distance in inches,
- K = 63" per second (the hand speed constant currently accepted by OSHA; see NOTE 1)
- T_S = the stop time (in seconds) of the machine, measured from the application of the "stop" signal to the final ceasing of all motion, including stop times of all relevant control elements, and measured at maximum machine velocity (see NOTE 2)
- T_R = 0.035 seconds (the response time of the Safety Module as measured from the time either hand disengages a hand control)
- T_H = the response time of the slowest hand control (from the time when a hand disengages that control until the switch opens; see NOTE 3)
- T_m = the maximum time (in seconds) the machine takes to cease all motion after it has been tripped. For full-revolution clutch presses with only one engaging point, T_m is equal to the time necessary for one and one-half revolutions of the crankshaft. For full-revolution clutch presses with more than one engaging point, T_m is calculated as follows:

$$T_m = (1/2 + 1/N) \times T_{CY}$$

where:

N = number of clutch engaging points per revolution

T_{CY} = time (in seconds) necessary to complete one revolution of the crankshaft

DUO-TOUCH® SG – Model AT-FM-10K Two-Hand Control Module

Electrical Installation

It is not possible to give exact wiring instructions for a Safety Module which interfaces to a multitude of machine control configurations. The following guidelines are general in nature.

The Safety Module has no delay function. Its output relay contacts open within 35 milliseconds after a safety input opens. This classifies the Safety Module as functional stop “Category 0”, as defined by NFPA 79 and IEC/EN 60204-1.

Connection of Power to the DUO-TOUCH SG Safety Module

The Safety Module requires a 24V ac/dc supply voltage (see Specifications on page 11). Use extreme caution whenever installing ac power. Use a minimum of 16 to 18 AWG wire for power and output connections. Use a minimum of 20 AWG wire for all other terminal connections. A hand-operated supply disconnect and over-current protection (e.g., a circuit breaker) must be provided per ANSI NFPA79 and IEC/EN60204-1.

Connection of Input Switches (Hand Control Actuators)

The actuation devices are connected to the DUO-TOUCH SG Module as shown in Figures 4a, 4b, and 4c. SW1 and SW2 must both have normally open and normally closed output contacts, or two current-sourcing complementary outputs each, all capable of reliably switching 25 mA at 24V dc (nominal). If hand controls have metal housings, the housings must be connected to protective earth ground.

If STB Touch Buttons with PNP outputs are used, the entire STB/AT-FM-10K system must be supplied with 24V dc. Electronic actuation devices, including STB Touch Buttons, must share the same voltage supply with the Safety Module (see Electronic Hand Control WARNING on page 7).

Connection to the Guarded Machine

Figure 4 shows a generic connection of the Safety Module’s redundant output contacts to machine primary control elements MPCE1 and MPCE2. An MPCE is defined as an electrically-powered element, external to the Safety Module, which directly controls the machine’s normal operating cycle so that it is the last (in time) to operate when the cycle is either initiated or arrested. Some older machines offer only one MPCE; for such machines, it may be necessary to add a second MPCE to establish the appropriate level of safety integrity (e.g., control reliability).

The connection of the safety outputs must be in such a manner that the stop command issued by the Safety Module can not be overridden by a device or circuit that is not at the same level of safety integrity. This means that the safety outputs are interfaced on the output of the machine logic (e.g., PLC or PC). Then, normally, a feedback signal identifies to the machine logic the status of the Safety Module and, if possible, the status of the MPCEs.

In summary, Control Reliability (OSHA 29CFR1910.217, ANSI B11, and ANSI/RIA R15.06) and Category 3 and 4 (ISO13849-1) requirements demand that a single failure does not lead to the loss of the safety function, or does not prevent a normal or immediate stop from occurring. The failure or the fault must be detected at or before the next demand of safety (e.g., at the beginning or end of a cycle, or when a safeguard is actuated). The safety-related function of the machine control then must issue an immediate stop command or prevent the next machine cycle or hazardous situation until the failure or fault is corrected.

External Device Monitoring

To satisfy the requirements of Control Reliability (OSHA and ANSI) and Category 3 and 4 of ISO 13849-1 (EN 954-1), the machine primary control elements (MPCEs) must each offer a normally closed, forced-guided (mechanically linked) monitor contact. Connect one normally closed monitor contact from each master stop control element in series to Y1 and Y2 (see hookup drawings).

CAUTION . . . Shock Hazard

Always disconnect power from the Safety Module and all power from the machine being controlled before making any connections or replacing any component.

Electrical installation and wiring must be made by qualified personnel and must comply with the NEC (National Electrical Code), ANSI NFPA79 or IEC 60204-1, and all applicable local standards and codes.

WARNING . . . Safety Circuit Integrity (Categories)

The level of safety circuit integrity can be greatly impacted by the design and installation of the Safety Module. A risk assessment must be performed to determine the appropriate safety circuit integrity level or safety category as described by ISO 13849-1 to ensure that the expected risk reduction is achieved and that all relevant regulations and standards are complied with.

WARNING . . . Interfacing MSCs

NEVER wire any intermediate device(s) (e.g., PLC, PES, PC), between the Safety Module outputs and the master stop control element (MSC) it switches, in such a manner that in the event of a failure there is the loss of the safety stop command, OR in such a manner that the safety function can be suspended, overridden, or defeated, unless accomplished with the same or greater degree of safety. Whenever forced-guided (mechanically linked) relays are added as intermediate switching devices, a normally closed forced-guided monitor contact from each relay must be added to the series feedback loop between Safety Module terminals Y1 and Y2.

DUO-TOUCH® SG – Model AT-FM-10K Two-Hand Control Module

⚠ WARNING . . . Interfacing Safety Outputs

Never wire or interface an intermediate device (e.g., PLC, PES, PC) that can fail in such a manner that there is a loss of the safety stop command to the MPCEs. To do so could result in serious bodily injury or death. See page 6, "Connection to the Machine to be Controlled."

⚠ WARNING . . . Use of Electronic Hand Controls

Electronic (powered) hand controls include optical touch buttons, capacitive touch buttons and similar devices. When electronic hand controls are used as input switches for a DUO-TOUCH SG Safety Module, the hand controls and the Safety Module must be powered from the same voltage source. Failure to do so creates a potentially dangerous condition, which could result in serious injury or death.

If power is applied to the Safety Module before power is applied to the electronic hand controls, an output from the DUO-TOUCH SG Safety Module could result and may trigger machine motion. Also, electronic hand controls cannot guarantee the state of their outputs at the time power is applied to them.

⚠ WARNING . . . Wiring of Arc Suppressors

If arc suppressors are used, they **MUST** be installed as shown across the actuator coil of the master stop control elements (MPCE1 and MPCE2). NEVER install suppressors directly across the output contacts of the Safety Module. It is possible for suppressors to fail as a short circuit. If installed directly across the output contacts of the Safety Module, a short-circuited suppressor will create an unsafe condition which could result in serious injury or death.

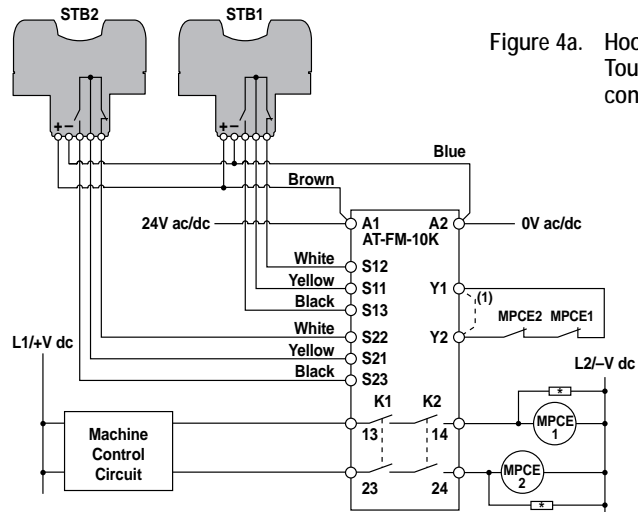

Figure 4a. Hookups to two STB Touch Buttons with contact outputs

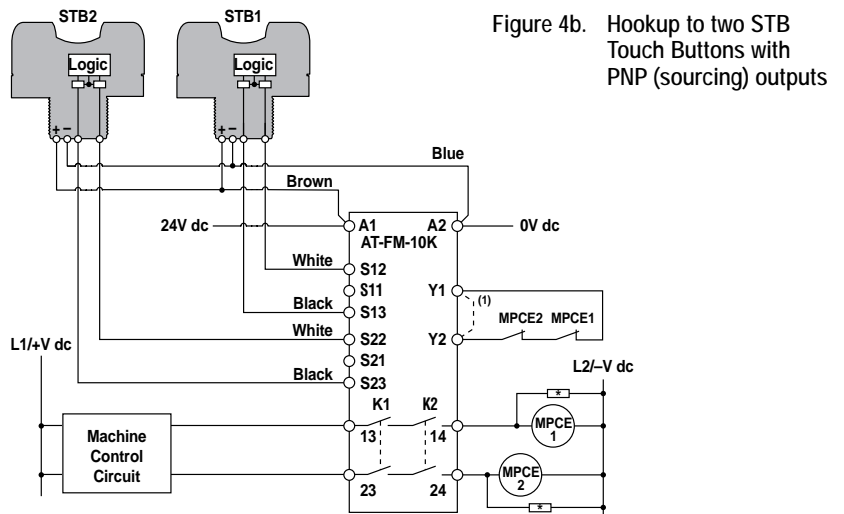

Figure 4b. Hookup to two STB Touch Buttons with PNP (sourcing) outputs

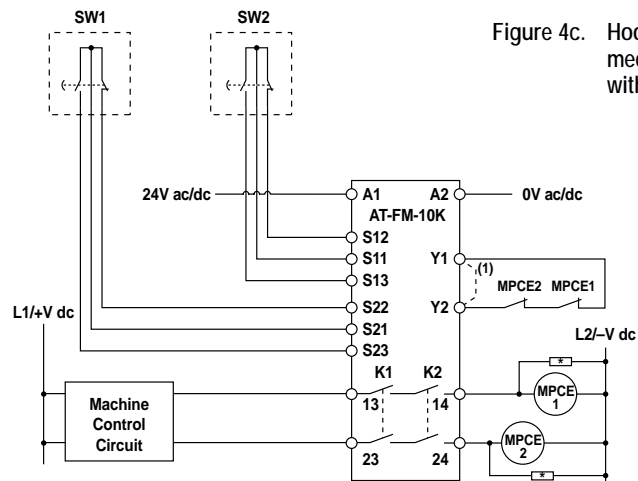

Figure 4c. Hookup to two mechanical push buttons with contact outputs

* Arc Suppressor – See Warning
(1) See Warning about Interfacing Safety Outputs

Figure 4. Hookups

DUO-TOUCH® SG – Model AT-FM-10K Two-Hand Control Module

In operation, if one of the switching contacts of either MPCE fails in the energized condition, the associated monitor contact will remain open. Therefore, it will not be possible to reset the Safety Module. If no MPCE-monitor contacts are monitored, a jumper must be installed between terminals Y1 and Y2 (dotted line), as shown in the hookup drawings. It is the user's responsibility to ensure that any single failure will not result in a hazardous condition and will prevent a successive machine cycle.

Overvoltage Category II and III Installations (EN 50178 and IEC 60664-1)

The Safety Module is rated for Overvoltage Category III when voltages of 1V to 150V ac/dc are applied to the output relay contacts. It is rated for Overvoltage Category II when voltages of 151V to 250V ac/dc are applied to the output relay contacts and no additional precautions are taken to attenuate possible overvoltage situations in the supply voltage. The Module can be used in an Overvoltage Category III environment (with voltages of 151V to 250V ac/dc) if care is taken either to reduce the level of electrical disturbances seen by the Module to Overvoltage Category II levels by installing surge suppressor devices (e.g., arc suppressors), or to install extra external insulation in order to isolate both the Safety Module and the user from the higher voltage levels of a Category III environment.

For Overvoltage Category III installations with applied voltages from 151V to 250V ac/dc applied to the output contact(s): the Safety Module may be used under the conditions of a higher overvoltage category where appropriate overvoltage reduction is provided. Appropriate methods include:

- An overvoltage protective device
- A transformer with isolated windings
- A distribution system with multiple branch circuits (capable of diverting energy of surges)
- A capacitance capable of absorbing energy of surges
- A resistance or similar damping device capable of dissipating the energy of surges

When switching inductive ac loads, it is good practice to protect the Safety Module outputs by installing appropriately-sized arc suppressors. However, if arc suppressors are used, they must be installed across the load being switched (e. g., across the coils of external safety relays), and never across the Safety Module's output contacts (see WARNING on page 7).

Initial Checkout Procedure

To perform the initial checkout, it is necessary to view the red Fault LED and the four green status indicators: Power, Input 1, Input 2 and Output. Proceed with caution around open wiring.

1. Verify that the two actuating devices are properly connected to the Module.
2. Apply power to the Safety Module and to the actuating devices, if applicable.
3. Verify that only the Power indicator is ON. If any of the other Safety Module indicators are ON, disconnect the power to the Safety Module and check all wiring. Do not continue this checkout procedure until the cause of the problem is corrected.
4. Activate both hand controls simultaneously (within 0.5 seconds), and hold them engaged. Input 1 and Input 2 indicators should come ON. Release both hand controls simultaneously. Output indicator should go OFF.
5. Again, activate the two hand controls simultaneously, and hold them engaged. Input 1, Input 2, and Output indicators should come ON. Release one hand control, while holding the other engaged. One of the indicators should remain ON. The Output indicator should go OFF. Re-activate the hand control which was just released. The Output indicator should remain OFF. Release both hand controls. Input 1 and Input 2 indicators should then be OFF.

CAUTION . . . Disconnect Power Before Checkout

Before performing the initial checkout procedure, make certain all power is disconnected from the machine to be controlled. Temporarily disconnect the wires connected to the outputs of the DUO-TOUCH SG Safety Module at terminals 13/14 and 23/24.

WARNING . . . Do Not Use System Until Checkouts Are Verified

If all of the described checks cannot be verified, the two-hand control system must not be used until the problem has been corrected. Injury or death to personnel may result from attempts to use the machine under such conditions.

DUO-TOUCH® SG – Model AT-FM-10K Two-Hand Control Module

6. Activate only one hand control and hold it engaged. Input 1 (Input 2) indicator should come ON. After more than 1/2 second, activate the second hand control. Input 1 and 2 indicators should remain ON, while Output indicator remains OFF.
7. Remove power from the Safety Module and disconnect the monitor contact feedback loop at terminals Y1 and/or Y2. Re-apply power to the Safety Module. Activate both hand controls simultaneously. Output indicator LED should remain OFF.

If the DUO-TOUCH SG Safety Module passes all of these tests, reconnect the output wires at terminals 13/14 and 23/24. Do not attempt to use the DUO-TOUCH SG Two-Hand Control Safety Module until all of the tests are passed.



WARNING ... Do Not Use System Until Checkouts Are Verified

If all of the described checks cannot be verified, the two-hand control system must not be used until the problem has been corrected. Injury or death to personnel may result from attempts to use the machine under such conditions.

Periodic Checkout and Maintenance

Daily Checkout:

To be Performed at every Power-up, Shift Change, and Machine Setup Change

Daily checkout and checkouts after tooling and machine setup changes must be performed by a Designated Person, appointed and identified in writing by the employer.

1. Verify that all point-of-operation guards are in place and operating properly.
2. Verify that the two actuating devices must be simultaneously engaged to actuate the machine.
3. For single-cycle machines: Verify that maintained engagement of the two actuating devices results in only one machine cycle.
4. For part-revolution clutch machinery: Verify that release of either actuating device results in the immediate arrest of the machine motion.
5. Verify that the distance from each actuating device to the closest hazard point is not less than the calculated safety distance (see page 5).

Semi-Annual Checkout:

To be Performed at Six-Month Intervals

This semi-annual checkout must be performed by a Qualified Person.* A copy of test results should be kept on or near the machine.

1. Perform the daily checkout procedure.
2. Perform the initial checkout procedure.
3. Calculate the separation distance (see page 5), and verify that the actuating devices are far enough away from the nearest hazard point. Relocate the actuating devices, if necessary.
4. Verify that the actuating devices are positioned to require the use of both hands for operation, and are protected from false or inadvertent operation.
5. Inspect the machine controls and the connections to the Safety Module to ensure that wiring is correct, as described on page 7, and that no modifications have been made which could adversely affect the System.

* **Qualified Person:** A person who, by possession of a recognized degree or certificate of professional training, or who, by extensive knowledge, training, and experience, has successfully demonstrated the ability to solve problems relating to the installation, maintenance and use of the DUO-TOUCH SG Two-Hand Control Safety System.

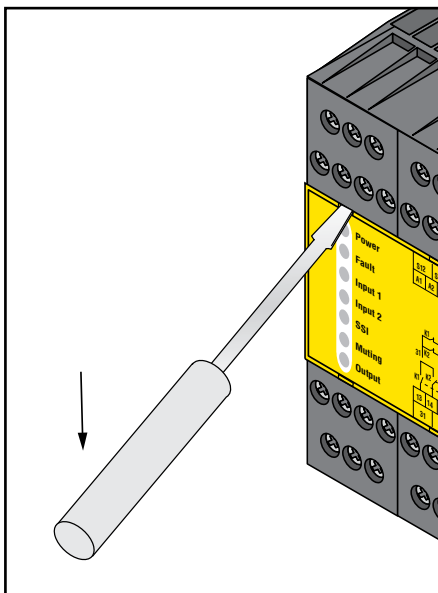

Figure 5. To remove a terminal block, insert a small screwdriver into the slot as shown, and pry to loosen.

DUO-TOUCH® SG – Model AT-FM-10K Two-Hand Control Module

Repairs

NOTE: Do not attempt any repairs to the DUO-TOUCH SG Two-Hand Control Module. It contains no field-replaceable components. Return it to the factory for warranty repair or replacement.

If it ever becomes necessary to return a DUO-TOUCH SG Safety Module to the factory, please do the following:

1. Contact the Banner Factory Application Engineering Group at the address or at the numbers listed at the bottom of the back page. They will attempt to troubleshoot the system from your description of the problem. If they conclude that a component is defective, they will issue an RMA (Return Merchandise Authorization) number for your paperwork, and give you the proper shipping address.
2. Pack the component carefully. Damage which occurs in return shipping is not covered by warranty.

CAUTION ... Abuse of Module After Failure

If an internal fault has occurred and the Module will not reset, do not tap, strike, or otherwise attempt to correct the fault by a physical impact to the housing. An internal relay may have failed in such a manner that its replacement is required.

If the Module is not immediately replaced or repaired, multiple simultaneous failures may accumulate such that the safety function can not be guaranteed.

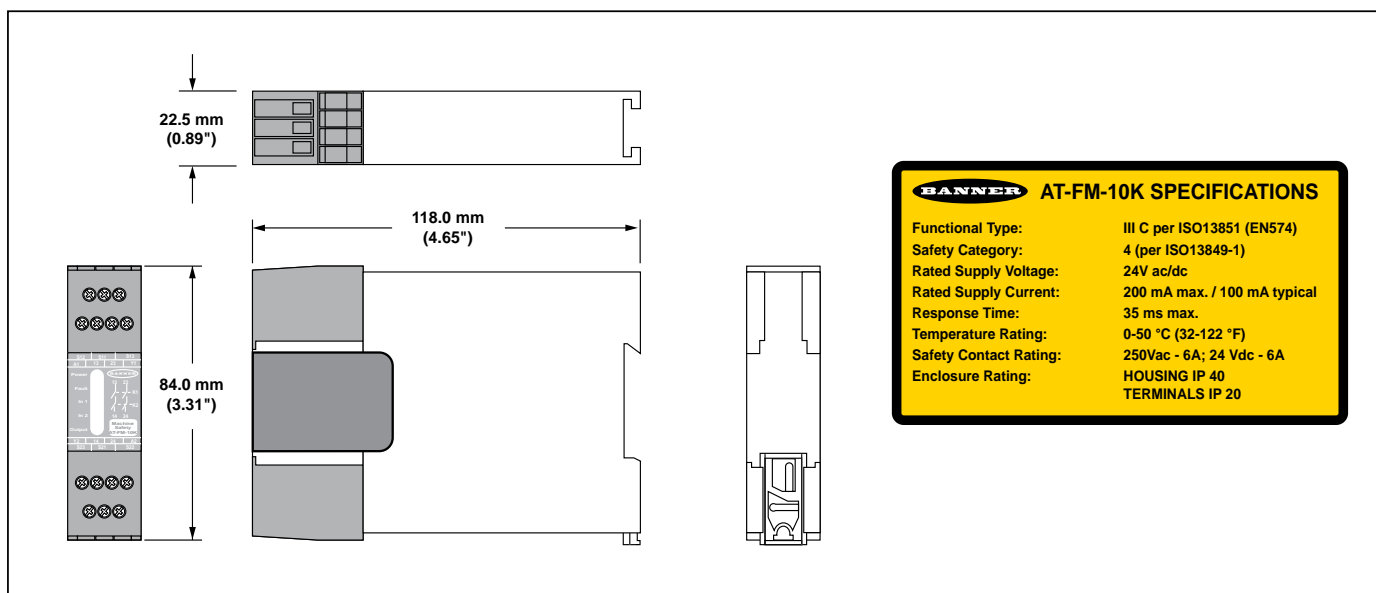

Figure 6. Dimensions and label

Accessories

Consult your Banner catalog or visit Banner Engineering website for details about the following accessories:



STB Self-Checking Buttons

- Solid-state outputs, 10-30V dc
- E/m relay outputs, 20-30V ac/dc
- See data sheet 64136 for more information.

DUO-TOUCH Run Bars with STB Self-Checking Touch Buttons

- Kits available including Safety Module, telescoping stands, other accessories.
- See data sheet 131634 for more information.



EZ-LIGHT® for Two-Hand Control

- Four-color indication: red, blue, green, and yellow
- Two housing styles
- See data sheet 134100 for more information.

DUO-TOUCH[®] SG – Model AT-FM-10K Two-Hand Control Module

Specifications

Supply Voltage and Current	24V dc $\pm 15\%$ @ 150 mA (use a SELV-rated supply according to EN IEC 60950, NEC Class 2) 24V ac $\pm 15\%$ @ 150 mA, 50-60 Hz $\pm 5\%$ (use an NEC Class 2-rated transformer) To comply with UL and CSA standards, the installation's isolated secondary power supply circuit must incorporate a method to limit the overvoltage to 0.8 kV.														
Supply Protection Circuitry	Protected against transient voltages and reverse polarity														
Overvoltage Category	Output relay contact voltage of 1V to 150V ac/dc: Category III Output relay contact voltage of 151V to 250V ac/dc: Category II (Category III, if appropriate overvoltage reduction is provided, as described on page 8.)														
Pollution Degree	2														
Output Configuration	Each normally open output channel is a series connection of contacts from two forced-guided (mechanically linked) relays, K1-K2. Contacts: AgNi, 5 μ m gold-plated <u>Low Current Rating:</u> The 5 μ m gold-plated contacts allow the switching of low current/low voltage. In these low-power applications, multiple contacts can also be switched in series (e.g., "dry switching"). To preserve the gold plating on the contacts, do not exceed the following max. values at any time: <table style="margin-left: 40px; border: none;"> <tr> <td>Min. voltage: 1V ac/dc</td> <td>Max. voltage: 60V</td> </tr> <tr> <td>Min. current: 5 mA ac/dc</td> <td>Max. current: 300 mA</td> </tr> <tr> <td>Min. power: 5 mW (5 mVA)</td> <td>Max. power: 7 W (7 VA)</td> </tr> </table> <u>High Current Rating:</u> If higher loads must be switched through one or more of the contacts, the minimum and maximum values of the contact(s) changes to: <table style="margin-left: 40px; border: none;"> <tr> <td>Minimum:</td> <td>Maximum:</td> </tr> <tr> <td>Voltage: 15V ac/dc</td> <td>250V ac / 24V dc, 6 A resistive</td> </tr> <tr> <td>Min. current: 30 mA ac/dc</td> <td>B300, R300 per UL508</td> </tr> <tr> <td>Min. power: 0.45 W (0.45 VA)</td> <td>IEC 60947-5-1; AC15: 230V ac, 3 A; DC-13: 24V dc, 2 A</td> </tr> </table> Mechanical life: 20,000,000 operations Electrical life (switching cycles of the output contacts, resistive load): 150,000 cycles @ 900 VA; 1,000,000 cycles @ 250 VA; 2,000,000 cycles @ 150 VA; 5,000,000 cycles @ 100 VA NOTE: Transient suppression is recommended when switching inductive loads. Install suppressors across load. Never install suppressors across output contacts (see Warning, page 7).	Min. voltage: 1V ac/dc	Max. voltage: 60V	Min. current: 5 mA ac/dc	Max. current: 300 mA	Min. power: 5 mW (5 mVA)	Max. power: 7 W (7 VA)	Minimum:	Maximum:	Voltage: 15V ac/dc	250V ac / 24V dc, 6 A resistive	Min. current: 30 mA ac/dc	B300, R300 per UL508	Min. power: 0.45 W (0.45 VA)	IEC 60947-5-1; AC15: 230V ac, 3 A; DC-13: 24V dc, 2 A
Min. voltage: 1V ac/dc	Max. voltage: 60V														
Min. current: 5 mA ac/dc	Max. current: 300 mA														
Min. power: 5 mW (5 mVA)	Max. power: 7 W (7 VA)														
Minimum:	Maximum:														
Voltage: 15V ac/dc	250V ac / 24V dc, 6 A resistive														
Min. current: 30 mA ac/dc	B300, R300 per UL508														
Min. power: 0.45 W (0.45 VA)	IEC 60947-5-1; AC15: 230V ac, 3 A; DC-13: 24V dc, 2 A														
Output Response Time	35 milliseconds maximum														
Input Requirements	Outputs from actuating devices must each be capable of switching 25 mA @ 24V dc (nominal).														
Simultaneity Monitoring Period	≤ 500 milliseconds														
Status Indicators	4 green LED indicators: Power ON, Input 1 energized, Input 2 energized, Output 1 red LED indicator: Fault														
Construction	Polycarbonate housing. Rated IEC IP20														
Mounting	Mounts to standard 35 mm DIN rail track. Safety Module must be installed inside an enclosure rated NEMA 3 (IEC IP54), or better.														
Vibration Resistance	10 to 55 Hz @ 0.35 mm displacement per IEC 60068-2-6														
Operating Conditions	Temperature: 0° to +50°C (+32° to 122°F) For heat dissipation considerations, see page 4. Maximum Relative Humidity: 90% @ +50°C (non-condensing)														
Dimensions	See Figure 6.														
Design Standards	CE: Cat. 4 PL e, per EN ISO 13849-1; SIL 3 per IEC 61508 and IEC 62061; Type IIIC per ISO 13851 (EN574) (when used with STBs or hard contacts)														
Certifications	