

Emergency Stop Safety Modules

Model ES-UA-5A for 12-24V dc/115V ac operation; Model ES-VA-5A for 12-24V dc/230V ac operation

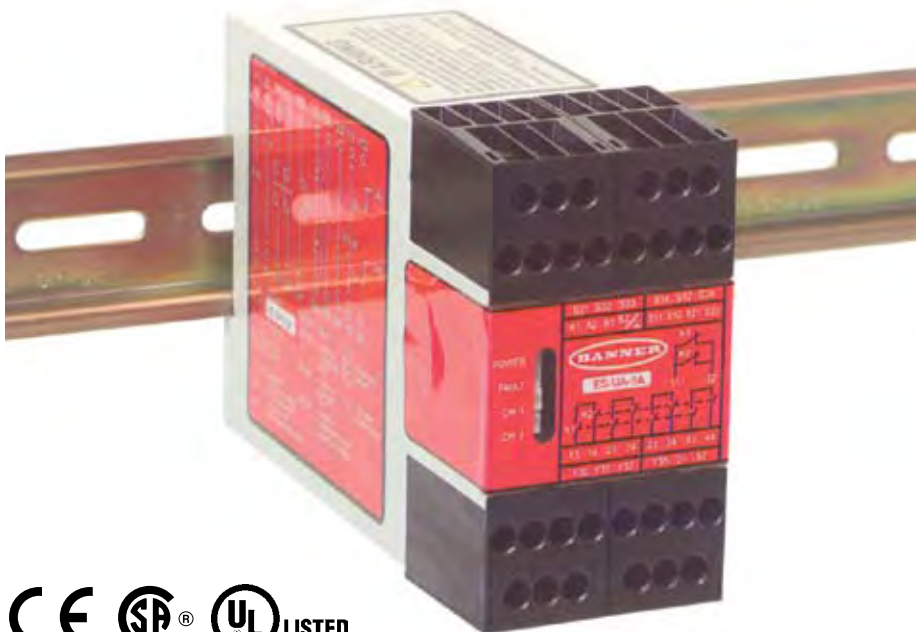

Features

- Monitors one dual-channel normally closed Emergency Stop switch circuit for a contact failure or wiring fault
- Four output switching channels for connection to control-reliable power interrupt circuits
- Auto reset or monitored manual reset
- Design complies with standards UL 991, EN 418, and EN 954-1 (Category 4)
- For use in functional stop category 0 applications per NFPA 79 and IEC/EN 60204-1
- 6 amp safety output contacts
- Plug-in terminal blocks
- 12-24V dc/115V ac or 12-24V dc/230V ac operation
- External Device Monitoring (one-channel EDM)



WARNING . . .

This Emergency Stop Safety Module is not a point-of-operation guarding device, as defined by OSHA regulations. It is necessary to install point-of-operation guarding devices, such as safety light curtains and/or hard guards, to protect personnel from hazardous machinery. Failure to install point-of-operation guards on hazardous machinery can result in a dangerous condition which could lead to serious injury or death.

E-Stop Safety Module – Models ES-UA-5A and ES-VA-5A



Important ... read this page before proceeding!

Banner Engineering Corp. has made every effort to provide complete application, installation, operation, and maintenance instructions. In addition, any questions regarding the use or installation of this Banner Emergency Stop Safety Module should be directed to the factory applications department at the telephone numbers or address shown on back cover.

The user shall ensure that all machine operators, maintenance personnel, electricians, and supervisors are thoroughly familiar with and understand all instructions regarding the installation, maintenance, and use of this Emergency Stop Safety Module, and with the machinery it controls.

The user and any personnel involved with the installation and use of this model Emergency Stop Safety Module must be thoroughly familiar with all applicable ANSI/NFPA standards. The standards, listed below, directly address the use of emergency stop systems. Banner Engineering Corp. makes no claim regarding a specific recommendation of any organization, the accuracy or effectiveness of any information provided, or the appropriateness of the provided information for a specific application.

The user has the responsibility to ensure that all local, state, and national laws, rules, codes, and regulations relating to the use of this Emergency Stop Safety Module in any particular application are satisfied. Extreme care is urged that all legal requirements have been met and that all installation and maintenance instructions contained in this manual are followed.

U. S. Standards Applicable to Use of Emergency Stop Safety Modules

ANSI B11	Standards for Machine Tools "Safety Requirements for the Construction, Care and Use" Available from: Safety Director AMT – The Association for Manufacturing Technology 7901 Westpark Drive McLean, VA 22102 Tel.: 703-893-2900
NFPA 79	"Electrical Standard for Industrial Machinery (1997)" Available from: National Fire Protection Association 1 Batterymarch Park, P.O. Box 9101 Quincy, MA 02269-9101 Tel.: 800-344-3555
ANSI/RIA R15.06	"Safety Requirements for Industrial Robots and Robot Systems" Available from: Robotic Industries Association 900 Victors Way, P.O. Box 3724 Ann Arbor, MI 48106 Tel.: 734-994-6088

European Standards Applicable to Use of Emergency Stop Safety Modules

ISO/TR 12100-1 & -2 (EN 292-1 & -2)	"Safety of Machinery – Basic Concepts, General Principles for Design Part 1: Basic Terminology, Methodology, and Part 2: Technical Principles and Specifications"
EN 954-1	"Safety of Machines: Safety Related Parts of Control Systems: Part 1 General Principles for Design"
IEC/EN 60204-1	"Electrical Equipment of Machines: Part 1: General Requirements" Also, request a type "C" standard for your specific machinery.
EN 418	"Safety of Machinery – Emergency Stop Equipment Functional Aspects, Principles for Design" Available from: Global Engineering Documents 15 Inverness Way East Englewood, CO 80112-5704 Tel.: 800-854-7179

E-Stop Safety Module – Models ES-UA-5A and ES-VA-5A

Overview

The purpose of an Emergency Stop Safety Module (E-Stop Safety Module) is to increase the control reliability of an emergency stop circuit. As indicated in Figures 2 and 3, the models ES-UA-5A and ES-VA-5A E-Stop Safety Modules are designed to monitor a 1-channel or 2-channel E-stop switch. A 2-channel E-stop switch has two electrically isolated contacts.

EN 954-1 Safety Categories

Both contacts of a 2-channel E-stop switch are monitored by the Safety Module. If either input is short-circuited, the Safety Module cannot be reset, and the controlled machinery cannot be restarted, following actuation of the E-stop switch. Two-channel E-stop switches used with this Safety Module are suitable for Safety Category 4 applications, per European Standard ISO 13849-1 (EN 954-1), of which Category 4 is the highest safety category.

Use of a 1-channel E-stop switch provides no input redundancy, and no ability for the Safety Module to monitor for input short circuits. One-channel E-stop switches used with this Safety Module are generally suitable only for Safety Category 2 applications, per ISO 13849-1 (EN 954-1).

IEC/EN 60204-1 and NFPA 79 Functional Stop Categories

In a functional Category 0 emergency stop circuit, the opening of either of the two E-stop switch contacts (or the one contact, if configured to 1-channel) immediately removes electrical power from the machine control elements, which react to stop hazardous machine motion and/or other machine hazards. This redundancy of stopping control offered by a two-pole E-stop switch is the first step towards control reliability in an emergency stop circuit.

The output of the E-Stop Safety Module consists of four redundant output switching channels, each of which is the series connection of two forced-guided relay contacts that are internally monitored (K1 and K2 in Figures 4 and 5). If the Module detects a failure, such as a welded output relay contact, all outputs are disabled and cannot be reset. The four switching output circuits of the E-Stop Safety Module are rated for up to 250V ac at up to 6 amps.

The E-Stop Safety Module also provides a necessary reset function. U.S. and international standards require that a reset/restart routine be performed after returning the E-stop switch to its closed-contact position. This prevents the controlled machinery from restarting by simply closing the E-stop switch. The Module may also be configured for automatic reset (see Figures 4 and 5). **The automatic reset mode is useful for some automated processes. However, when automatic reset is used, an alternate means must be established to require a reset/restart routine after the E-stop switch is returned to its closed contact position (see WARNING on page 8).**

This E-Stop Safety Module complies with the following design standards:

- UL 991 Tests for Safety Related Control Employing Solid-State Devices
- EN 418 Emergency Stop Equipment—Functional Aspects, Principles for Design
- EN 954-1 Safety of Machines: Safety Related Parts of Control Systems Part 1: General Design Directives (Safety Category 4)

The Safety Module has indicators for input power, fault, and output relay contact status (K1 and K2); see Figure 1. There are no adjustments and no user-serviceable parts. See page 10 for information regarding repair service.

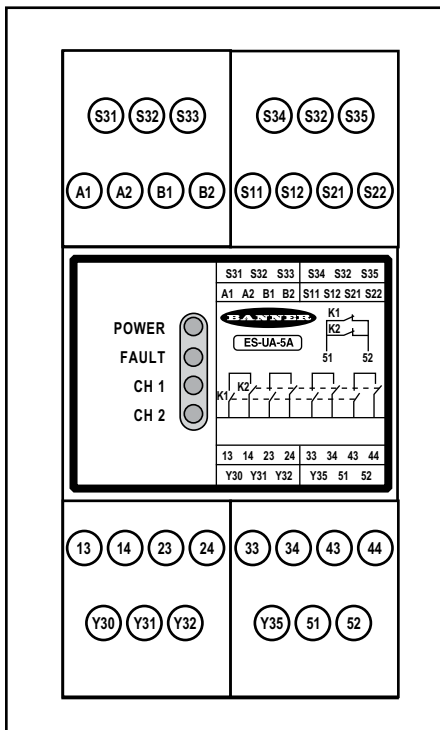

Figure 1. ES-UA-5A and ES-VA-5A Status Indicators and Terminal Locations

E-Stop Safety Module – Models ES-UA-5A and ES-VA-5A

E-Stop Switch Requirements

As shown in Figures 4, 5, and 6, the E-stop switch must provide contacts which are closed when the switch is in the “armed” position. Once activated, the E-stop switch must open its contacts and be returned to the closed-contact position *only* by a deliberate action (such as twisting, pulling, or unlocking). The switch should be a “positive-opening type,” as described by IEC 60947-5-1. A mechanical force applied to such a button (or switch) is transmitted directly to the contacts, forcing them open. This ensures that the switch contacts will open whenever the switch is activated.

NFPA 79 specifies the following additional Emergency Stop Actuator requirements:

- Emergency Stop push buttons shall be located at each operator control station and at other operating stations where emergency shutdown shall be required.
- Stop and Emergency Stop push buttons shall be continuously operable from all control and operating stations where located.
- Actuators of Emergency Stop devices shall be colored RED. The background immediately around the device actuator shall be colored YELLOW. The actuator of a push-button-operated device shall be of the palm or mushroom-head type.
- The Emergency Stop actuator shall be a self-latching type.

NOTE: Some applications may have additional requirements. The user must refer to all relevant regulations.

When a 1-channel E-stop is used, the user must guard against failure modes that can result in an unsafe condition, for example the failure of the contact to a short circuit condition. A switch with positive opening operation should be used to reduce the possibility of a failure of the switch to open. A short circuit failure results in loss of switching function. This can occur from a short across the switch contacts, a short across the wires connected to the switch somewhere between the switch and the E-Stop Safety Module, or a short to a secondary source of power. To reduce these possibilities, physically separate the wires from each other and from other sources of power (e.g., in separate wireways or conduit).

According to the definition of European standard EN 954-1, a 1-channel E-stop should generally be used in applications where Safety Category 2 or less (1 or B) has been determined via a risk-assessment procedure.

Two-channel E-stops, with positive open switches, are designed to issue a stop command even in the event of a single failure of this type and provide a high level of safety.

If the Module is configured for 2-channel E-stop, the immediate normally open output contacts (13-14, 23-24, 33-34, and 43-44), will open as soon as at least one of the two E-stop contacts opens. Although simultaneity is not required, the E-stop contacts must both be open at the same time and then both be closed, to reset the output contacts. If not, the unit will go into a lockout condition that results in the outputs opening and requiring a reset after the fault has been corrected.



WARNING . . .

1-Channel Input

If a 1-channel E-stop button is used, a single fault (such as a short across the single contact or to a secondary source of power) can lead to the complete loss of safety.

A 1-channel E-stop should be used only in applications where such a fault can be excluded, or the resulting loss of safety cannot result in serious injury or death (Safety Category 2, 1 or B; see page 3).

If a 1-channel E-stop is used, separate the wires from each other and from other sources of power, by routing them through separate wireways or conduit in order to increase the reliability.



WARNING . . . Multiple

E-Stop Switches

Whenever two or more E-stop switches are connected to the same E-Stop Safety Module, the contacts of both switches must be connected together in series. This series combination is then wired to the respective Safety Module input. **Never connect the contacts of multiple E-stop switches in parallel to the E-Stop Safety Module inputs; this defeats the switch contact monitoring ability of the Safety Module, and creates an unsafe condition which could result in serious injury or death.**

E-Stop Safety Module – Models ES-UA-5A and ES-VA-5A

Mechanical Installation

The E-Stop Safety Module must be installed inside an enclosure. It is not designed for exposed wiring. It is the user's responsibility to house the Safety Module in an enclosure with NEMA 3 (IEC IP54) rating, or better.

Dimensions of the Safety Module are shown in the diagram on page 10. The Safety Module mounts directly to standard 35 mm DIN rail.

Heat Dissipation Considerations

For reliable operation, the user must ensure that the operating specifications are not exceeded. The enclosure must provide adequate heat dissipation, so that the air closely surrounding the Module does not exceed the maximum operating temperature stated in the Specifications (page 11). Methods to reduce heat build-up include venting, forced airflow (e.g., exhaust fans), adequate enclosure exterior surface area, and spacing between modules and other sources of heat.

Electrical Installation

It is not possible to give exact wiring instructions for a device such as an E-Stop Safety Module which interfaces to a multitude of machine control configurations. The following guidelines are general in nature.

The ES-UA-5A and ES-VA-5A Modules have no delay function. Their output relay contacts open within 25 milliseconds after an E-stop switch contact opens. This classifies these E-Stop Safety Modules as functional "Category 0" E-stop controls, as defined by NFPA 79 and IEC/EN 60204-1.

Connection of E-Stop Switch

Connect the poles of the E-stop switches as shown in Figures 4 and 6. The switches are shown in the "armed" position with both contacts closed. Multiple E-stop switches connected to one E-Stop Safety Module must be series connected (see Figure 2 and the warning on page 4).

Connection of Safety Switches

Models ES-UA-5A and ES-VA-5A may be used as safety gate monitoring modules. To achieve Category 4 operation per EN 954-1, two positive-opening safety switches operate concurrently when the gate or guard is opened (see Figure 3).

The Safety Modules verify concurrent opening of two contacts – one from each safety switch. Reset of the Safety Modules is not possible if one switch fails to open, or if a short circuit between the safety switches occurs.

Please contact the Banner Factory Applications Group at the numbers listed on the last page to discuss your intended use.



CAUTION . . . Shock Hazard

Always disconnect power from the E-Stop Safety Module and all power from the machine being controlled before making any wire connections.

Electrical installation and wiring must be made by qualified personnel and must comply with the NEC (National Electrical Code), EN 60204-1 and -2, and all applicable local standards and codes.

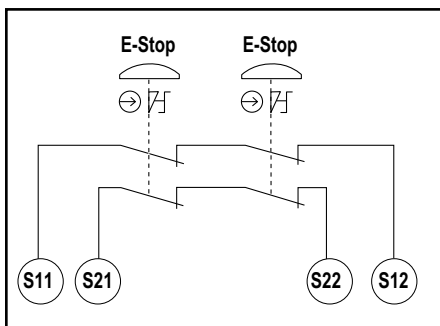

Figure 2. Series connection of multiple E-stop switches

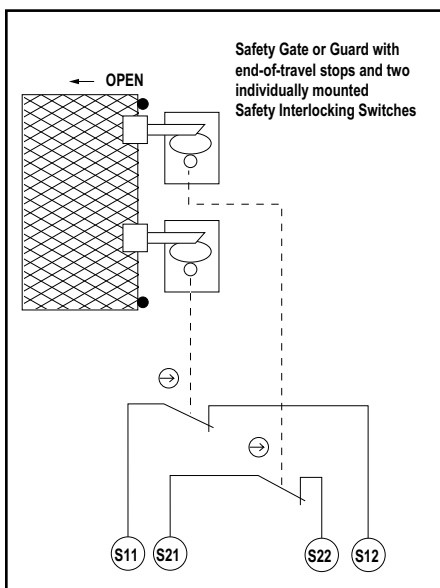

Figure 3. Hookup using contacts from two safety switches

E-Stop Safety Module – Models ES-UA-5A and ES-VA-5A

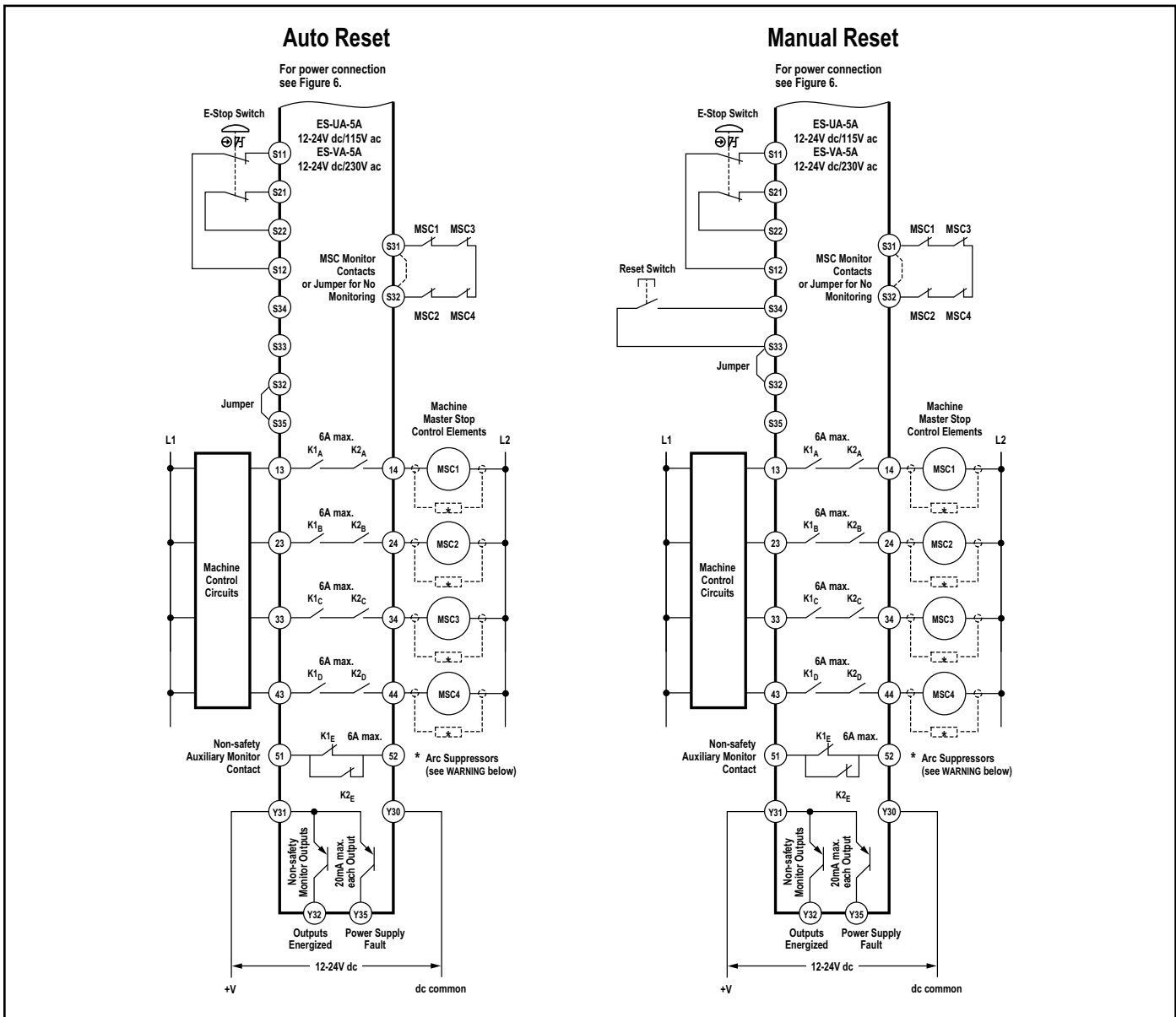

Figure 4. Hookup: 2-Channel E-Stop Applications



WARNING . . . Wiring of Arc Suppressors

If arc suppressors are used, they **MUST** be installed as shown across the actuator coil of the Master Stop Control Elements (MSC1 to MSC4). **NEVER** install suppressors directly across the output contacts of the E-Stop Safety Module. It is possible for suppressors to fail as a short circuit. If installed directly across the output contacts of the Safety Module, a short-circuited suppressor will create an unsafe condition which could result in serious injury or death.



WARNING . . . Interfacing MSCs

NEVER wire an intermediate device(s) (e.g., PLC, PES, PC), between E-Stop Safety Module outputs and the Master Stop Control Element it switches in such a manner that in the event of a failure there is the loss of the safety stop command, OR in such a manner that the safety function can be suspended, overridden, or defeated, unless accomplished with the same or greater degree of safety.

Whenever forced-guided, mechanically linked relays are added as intermediate switching devices, a normally closed forced-guided monitor contact from each relay must be added to the series feedback loop between Safety Module terminals S31 and S32.

E-Stop Safety Module - Models ES-UA-5A and ES-VA-5A

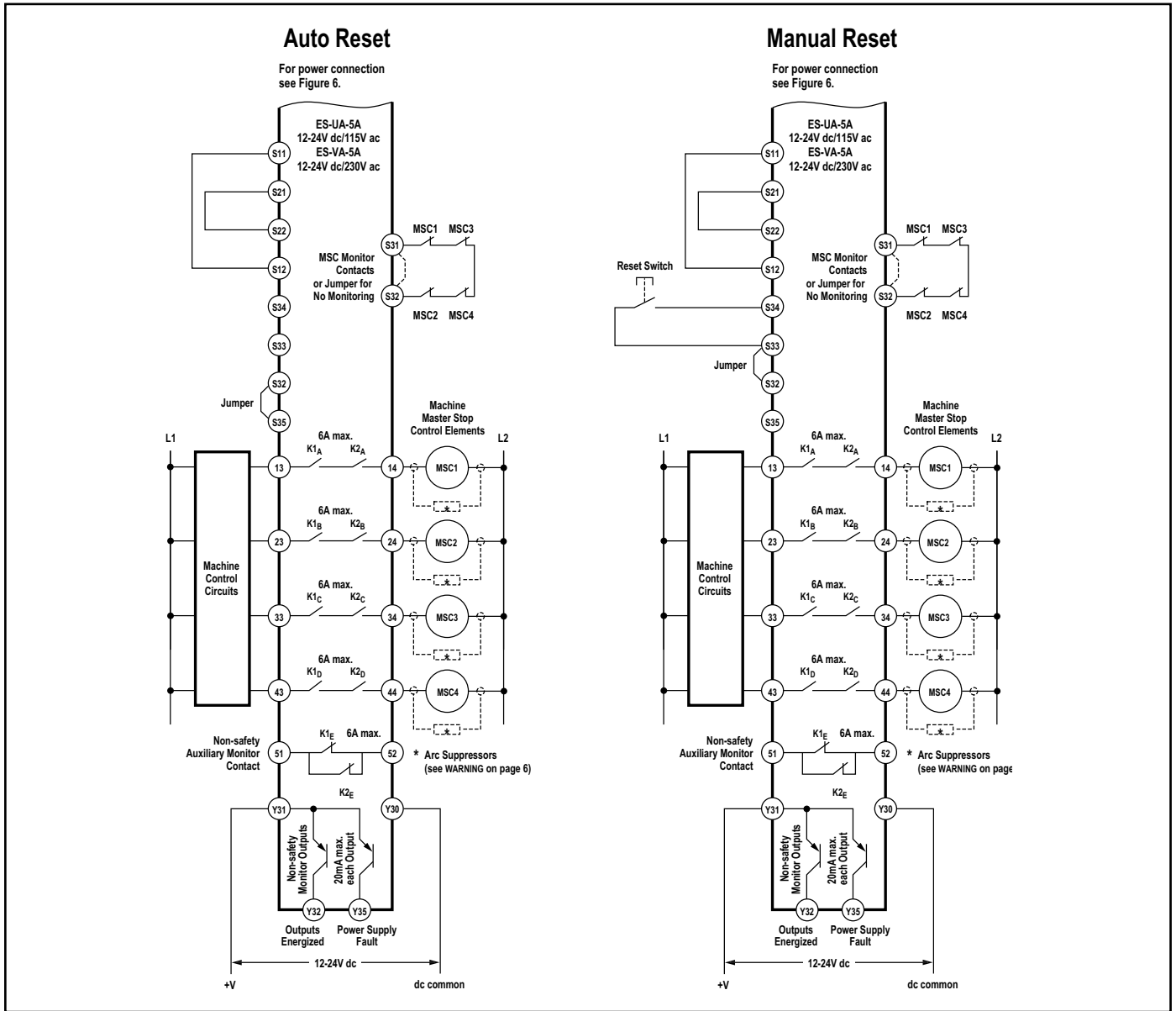

Figure 5. Hookup: 1-Channel E-Stop Applications

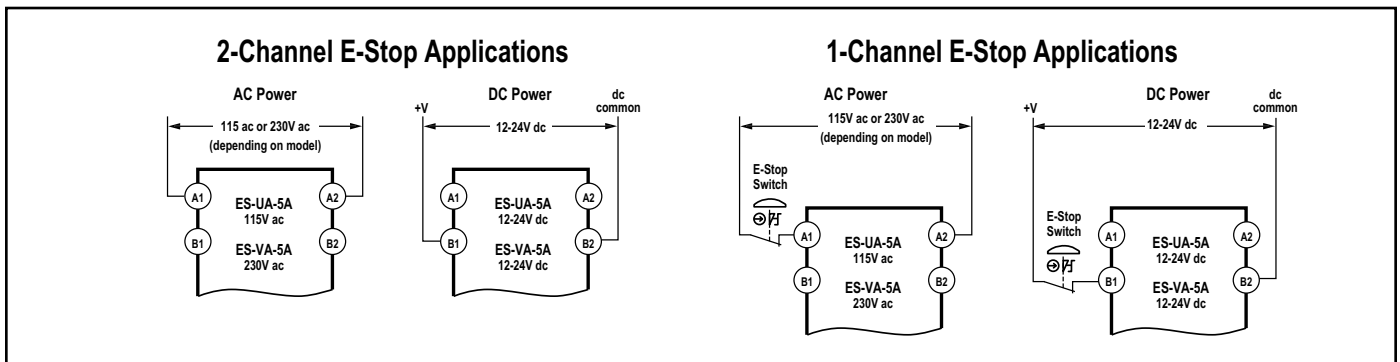

Figure 6. Power connections

E-Stop Safety Module – Models ES-UA-5A and ES-VA-5A

External Device Monitoring

To satisfy the requirements of Safety Category 4 of EN 954-1, the Master Stop Control Elements must each offer a normally closed, forced-guided monitor contact. One normally closed monitor contact from each Master Stop Control Element is wired in series to the S31-S32 feedback input (see Figures 4 and 5). In operation, if one of the switching contacts of either master stop control element fails in the shorted condition, the associated monitor contact will remain open. Therefore, it will not be possible to reset the E-Stop Safety Module. If no MSC-monitor contacts are monitored, a jumper must be installed between terminals S31 and S32 (see Figures 4 and 5). **It is the responsibility of the user to ensure that any single failure will not result in a hazardous condition and will prevent a successive machine cycle.**

Connection to the Machine to be Controlled

The hookup diagrams (Figures 4 and 5) show a generic connection of the E-Stop Safety Module's four redundant output circuits to Master Stop Control Elements MSC1 through MSC4. A Master Stop Control Element is defined as an electrically powered device, external to the E-Stop Safety Module, which stops the machinery being controlled by immediately removing electrical power to the machine and (when necessary) by applying braking to dangerous motion. This stopping action is accomplished by removing power to the actuator of either Master Stop Control Element.

Connection of Reset Switch

The Reset Circuit switch can be any mechanical switch such as a normally open momentary switch, or a two-position key switch. The Reset switch must be capable of reliably switching 12 to 18V dc at 40 to 100 milliamps. As shown in Figures 4 and 5, the Reset switch connects between terminals S33 and S34 of the Safety Module.

The Reset switch must be located outside of – and not be accessible from – the area of dangerous motion, and must be positioned so that any area of dangerous motion may be observed by the switch operator during the Reset procedure.

To perform a manual reset, close the normally open switch for at least 1/4 second, but no longer than 2 seconds, and then re-open the switch.

Automatic Reset Mode

Model ES-UA-5A or ES-VA-5A may be used also with automatic reset. If no MSC-monitor contacts are monitored, a jumper must be installed between terminals S31 and S32 (see Figures 4 and 5). The E-Stop Safety Module will reset (and the outputs energize) as soon as the E-stop switch returns to its closed-contact position.

The automatic reset mode is useful for some automated processes. **However, if automatic reset is used, it is necessary to provide an alternate means of preventing resumption of hazardous machine motion, until an alternate reset procedure is performed.** The alternate procedure must include a Reset/Restart switch, located outside the area of dangerous motion, which is positioned so that any area of dangerous motion may be observed by the switch operator during the reset procedure.

Auxiliary Monitor Contact/Solid-State Monitor Outputs Connection

The action of the auxiliary monitor contact, terminals 51/52, inversely “follows” the action of the safety outputs. The 51/52 auxiliary monitor contact is to be used only for control functions that are NOT safety-related.

There are two solid-state monitor outputs, each capable of switching up to 100 mA at 12-24V dc. One output at terminal Y32 follows the action of the output circuits (K1 and K2); the other output at terminal Y35 opens (low signal) when there is an internal power supply fault. A typical use is to communicate the status of the Safety Module output to a programmable logic controller (PLC). See Figure 4 for hookup information.



WARNING . . .
Reset Switch Location
Any Reset switch(es) used must be accessible only from outside, and in full view of, the hazardous area. Reset switches must also be out of reach from within the safeguarded space, and must be protected against unauthorized or inadvertent operation (e.g., through the use of rings or guards). If any areas are not visible from the Reset switch(es), additional means of safeguarding must be provided.



WARNING . . . Reset Routine Required
U.S. and international standards require that a reset routine be performed after returning the E-stop switch to its closed-contact position (when arming the E-stop switch). When automatic reset is used, an alternate means must be established to require a reset routine, after the E-stop switch is armed. **Allowing the machine to restart as soon as the E-stop switch is armed creates an unsafe condition which could result in serious injury or death.**

E-Stop Safety Module – Models ES-UA-5A and ES-VA-5A



CAUTION . . . Disconnect Power Prior to Checkout

Before performing the initial checkout procedure, make certain all power is disconnected from the machine to be controlled. Dangerous voltages may be present along the E-Stop Safety Module wiring barriers whenever power to the machine control elements is ON. Exercise extreme caution whenever machine control power is or may be present. Always disconnect power to the machine control elements before opening the enclosure housing of the E-Stop Safety Module.



WARNING . . . Multiple E-Stop Switches

When two or more E-stop switches are used, each switch must be individually actuated (engaged), then rearmed and the E-stop Safety Module reset (if using manual reset mode). This allows the monitoring circuits to check each switch and its wiring to detect faults. Failure to test each switch individually in this manner could result in undetected faults and create an unsafe condition which could result in serious injury or death.

Initial Checkout Procedure

Checkout procedure:

1. Remove power from the machine control elements.
2. Activate the E-stop switch (open its contacts).
3. Apply power to the E-Stop Safety Module at terminals A1 and A2 or B1 and B2 (see Figure 6). Verify that only the **Input Power** indicator (Figure 1) is ON. If either of the other two indicators is ON at this point, disconnect the input power and check all wiring. Return to step 2 after the cause of the problem has been corrected.
4. Arm the E-stop switch (close its contacts).
5. **Automatic reset:** K1 and K2 indicators should come ON, and the safety output contacts should close.
Manual reset: Close the Reset switch. The K1 and K2 indicators should continue flashing. Open the Reset switch. The K1 and K2 indicators should both come ON solid at this time. If either indicator comes ON solid before the Reset switch is opened, disconnect the input power and check all wiring. Return to step 2 after correcting the problem.
6. Activate the E-stop switch (open its contacts). The K1 and K2 indicators should turn OFF simultaneously. If either indicator remains ON, disconnect the input power and check all wiring. Return to step 2 after the cause of the problem has been corrected.
7. Close the enclosure. Apply power to the Machine Control Elements and perform the Periodic Checkout Procedure.

NOTE: If more than one E-stop switch is series-connected to one E-Stop Safety Module, the above checkout procedure must be run individually for EACH switch.

E-Stop Safety Module – Models ES-UA-5A and ES-VA-5A

Periodic Checkout Procedure

The functioning of the E-stop system must be verified on a regular periodic basis to ensure proper operation (see also the machine manufacturer's recommendations).

Procedure:

1. With the machine running, engage the E-stop switch (open its contact). Verify that the machine stops.
2. Return the E-stop switch to its closed-contact position. Verify that the machine does not restart.
3. Close and then open the Reset switch (if using manual reset mode). Verify that the machine can be restarted by normal initiation.

NOTE: If two or more E-stop switches are series-connected to one E-Stop Safety Module, this test must be run individually for EACH switch.

Repairs

NOTE: Do not attempt any repairs to the Emergency Stop Safety Module. It contains no field-replaceable components. Return the Safety Module to the factory for warranty repair or replacement.

If it ever becomes necessary to return an E-Stop Safety Module to the factory, please do the following:

1. Contact the Banner Factory Application Engineering Group at the address or at the numbers listed at the bottom of the back page. They will attempt to troubleshoot the system from your description of the problem. If they conclude that a component is defective, they will issue an RMA (Return Merchandise Authorization) number for your paperwork, and give you the proper shipping address.
2. Pack the E-Stop Safety Module carefully. Damage which occurs in return shipping is not covered by warranty.

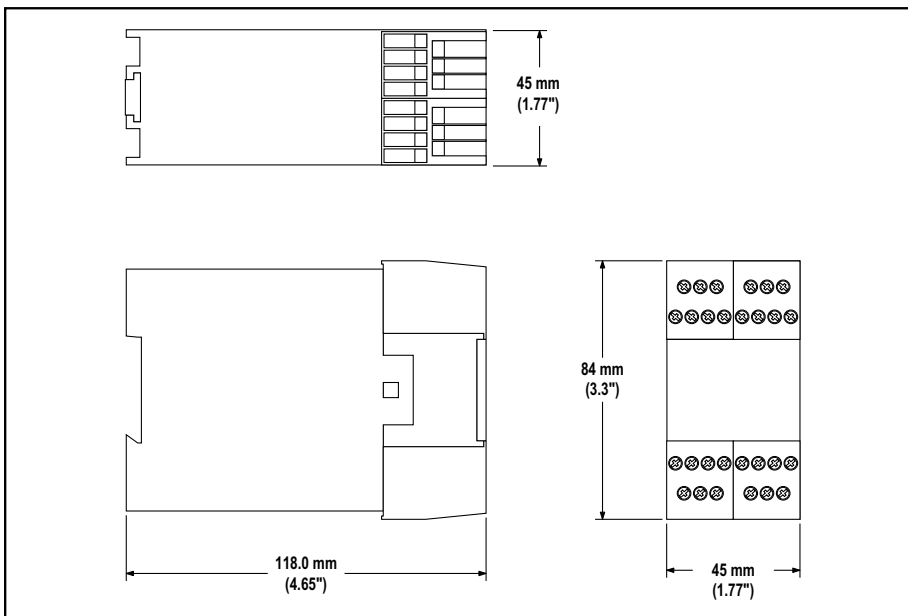

Figure 7. Model ES-UA-5A/ES-VA-5A E-Stop Safety Module enclosure dimensions



WARNING . . . Multiple E-Stop Switches

When two or more E-stop switches are used, each switch must be individually actuated (engaged), then re-armed and the E-Stop Safety Module reset (if using manual reset mode). This allows the monitoring circuits to check each switch and its wiring to detect faults. Failure to test each switch individually in this manner could result in undetected faults and create an unsafe condition which could result in serious injury or death.



CAUTION . . . Abuse of Module After Failure

If an internal fault has occurred and the ES-...A-5A will not reset, do not tap, strike, or otherwise attempt to correct the fault by a physical impact to the housing. An internal relay may have failed in such a manner that its replacement is required.

If the Module is not immediately replaced or repaired, multiple simultaneous failures may accumulate such that the safety function can not be guaranteed.

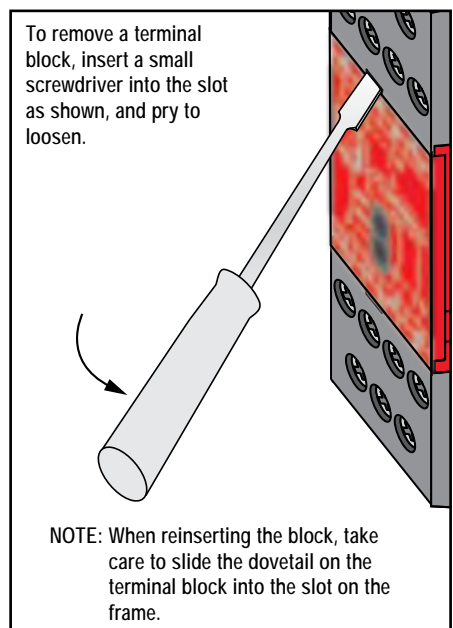





Figure 8. Removal of terminal blocks

E-Stop Safety Module – Models ES-UA-5A and ES-VA-5A

Specifications

Supply Voltage and Current	A1-A2: 115V ac (Model ES-UA-5A) or 230V ac (model ES-VA-5A), $\pm 15\%$; 50/60Hz B1-B2: 12-24V dc, $\pm 15\%$, 10% max. ripple Power consumption: approx. 4W/7VA												
Supply Protection Circuitry	Protected against transient voltages and reverse polarity												
Output Configuration	Outputs (K1 & K2): four redundant (total of eight) safety relay (forced-guided) contacts – AgNi, 5 μ m gold-plated, plus 1 N/C Auxiliary Monitor output – AgNi, 5 μ m gold-plated Low Current Rating: Caution: The 5 μ m gold-plated contacts allow the switching of low current/low voltage. In these low-power applications, multiple contacts can also be switched in series (e.g., “dry switching”). To preserve the gold plating on the contacts, the following max. values should not be exceeded at any time: <table style="width: 100%; border: none;"> <tr> <td style="width: 50%;">Min. voltage: 1V ac/dc</td> <td style="width: 50%;">Max. voltage: 60V</td> </tr> <tr> <td>Min. current: 5 mA ac/dc</td> <td>Max. current: 300 mA</td> </tr> <tr> <td>Min. power: 5 mW (5 mVA)</td> <td>Max. power: 7 W (7 VA)</td> </tr> </table> High Current Rating: If higher loads must be switched through one or more of the contacts, the minimum and maximum values of the contact(s) changes to: <table style="width: 100%; border: none;"> <tr> <td style="width: 50%;">Min. voltage: 15V ac/dc</td> <td style="width: 50%;">Max. voltage: 250V ac/dc</td> </tr> <tr> <td>Min. current: 250 mA ac/dc</td> <td>Max. current: 6 A</td> </tr> <tr> <td>Min. power: 5 W (5 VA)</td> <td>Max. power: 200 W (1500 VA)</td> </tr> </table> Mechanical life: 50,000,000 operations Electrical life: 150,000 operations (typical, @ 1,500 VA switched power, resistive load) 150,000 operations (typical, @ 200 W switched power, resistive load) NOTE: Transient suppression is recommended when switching inductive loads. Install suppressors across load. Never install suppressors across output contacts (see Warning, page 6). Solid-State Monitor Outputs: Two non-safety solid-state dc outputs Output at Y32 monitors state of outputs – conducts (output high) when both K1 and K2 are energized Output at Y35 conducts (output high) when internal power supply is OK Output circuits require application of +12-24V dc $\pm 15\%$ at terminal Y31; dc common at Y30 Maximum switching current: 100 mA at 12-24V dc Both outputs are protected against short circuits	Min. voltage: 1V ac/dc	Max. voltage: 60V	Min. current: 5 mA ac/dc	Max. current: 300 mA	Min. power: 5 mW (5 mVA)	Max. power: 7 W (7 VA)	Min. voltage: 15V ac/dc	Max. voltage: 250V ac/dc	Min. current: 250 mA ac/dc	Max. current: 6 A	Min. power: 5 W (5 VA)	Max. power: 200 W (1500 VA)
Min. voltage: 1V ac/dc	Max. voltage: 60V												
Min. current: 5 mA ac/dc	Max. current: 300 mA												
Min. power: 5 mW (5 mVA)	Max. power: 7 W (7 VA)												
Min. voltage: 15V ac/dc	Max. voltage: 250V ac/dc												
Min. current: 250 mA ac/dc	Max. current: 6 A												
Min. power: 5 W (5 VA)	Max. power: 200 W (1500 VA)												
Output Response Time	25 milliseconds typical												
Input Requirements	E-stop switch must have normally closed contacts each capable of switching 20 to 50mA @ 12 to 30V dc; and must be open 10 ms for a valid stop command. Maximum input resistance 250 Ω per channel. Reset switch must have one normally open contact capable of switching 20 to 50mA @ 12 to 30V dc.												
On-Time Delay	100 ms; time from the E-stop contacts to close (Auto Reset) or the reset button to open (Manual Reset) and the safety outputs to close.												
Status Indicators	3 green LED indicators: Power ON, K1 energized, K2 energized 1 red LED indicator responds to fault of internal power supply, ground fault, or cross-short of input channels (see “Troubleshooting” on back cover for LED condition descriptions).												
Housing	Polycarbonate. Rated NEMA 1 (IEC IP20)												
Mounting	Mounts to standard 35 mm DIN rail track. Safety Module must be installed inside an enclosure rated NEMA 3 (IEC IP54), or better.												
Vibration Resistance	10 to 55Hz @ 0.35 mm displacement per IEC 68-2-6												
Operating Conditions	Operating Temperature: 0° to +50° C (+32° to 122° F) Maximum Relative Humidity: 90% @ +50° C (non-condensing) Heat Dissipation Considerations: See page 5												
Dimensions	See Figure 7, page 10												
Certifications	   <small>EMERGENCY STOP DEVICE 2016</small>												

E-Stop Safety Module – Models ES-UA-5A and ES-VA-5A

Troubleshooting

Condition	Indicator Status	Possible Reasons/Solutions
Will not reset	Power LED ON Fault LED OFF Ch. 1 LED Flashing Ch. 2 LED Flashing	MSC Monitoring circuit open: • Check wiring at S31/S32. This must be a closed circuit before module can be reset. Reset mode-select open: • Check jumper at S32/S35 (auto reset) or S32/S33 (manual reset). • Check reset key connection.
	Power LED ON Fault LED OFF Ch. 1 LED OFF Ch. 2 LED OFF	Connector(s) loose: • Ensure connector and wire termination is properly seated. E-stop button open: • Re-arm E-stop button. • Check for short between channels.
	Power LED ON Fault LED OFF Ch. 1 LED OFF Ch. 2 LED ON	S11/S12 open; S21/S22 closed: • Check wiring. • Check switch. • Ensure connector and wire termination is properly seated. • Ensure both input channels are open a minimum of 0.5 seconds.
	Power LED ON Fault LED OFF Ch. 1 LED ON Ch. 2 LED OFF	S11/S12 closed; S21/S22 open: • Check wiring. • Check switch. • Ensure connector and wire termination is properly seated. • Ensure both input channels are open a minimum of 0.5 seconds.
	Power LED ON Fault LED ON or Flashing Ch. 1 LED OFF Ch. 2 LED OFF	Internal fault: • Return to factory for repair or replacement.
	All LEDs OFF	Possible fault in machine control or wiring to the module: • Check input power/ground. • Ensure connector and wire termination is properly seated.
	All LEDs Dim	Possible fault in machine control or input power: • Check input power and supply requirements of module.
Intermittently drops out, able to reset after cycling E-stop button	Momentary short between channels (e.g., S11 and S21): • Check for intermittent short between channels.	
MSCs do not energize	Possible fault in machine control, or an open circuit between machine control and MSCs: • Check continuity of safety outputs (e.g., between terminals 13 and 14). • Check control wires. • Check MSCs.	



more sensors, more solutions

WARRANTY: Banner Engineering Corp. warrants its products to be free from defects for one year. Banner Engineering Corp. will repair or replace, free of charge, any product of its manufacture found to be defective at the time it is returned to the factory during the warranty period. This warranty does not cover damage or liability for the improper application of Banner products. This warranty is in lieu of any other warranty either expressed or implied.