

Original Instructions



Features

- Monitors one or two safety switches for a contact failure or wiring fault
- Two output switching channels for connection to control-reliable power interrupt circuits
- Auto reset or monitored manual reset
- Design complies with standards UL991, ISO 14119, and ISO 13849-1 (EN954-1) (Safety Category 2, 3 or 4)
- For use in functional stop category 0 applications per NFPA 79 and IEC 60204-1
- 6 amp safety output contacts
- Plug-in terminal blocks
- If terminal blocks are swapped, Module remains functional with no loss of safety function

Overview

The GM-FA-10J Gate Monitor Safety Module (the "Safety Module") is used to verify the proper operation of coded magnetic safety switches and positive-opening safety switches by monitoring a normally open (N.O.) and a normally closed (N.C.) contact from each switch. It can also be used to monitor and verify the correct state of two redundant current-sourcing PNP signals. (One PNP source must be Normally OFF and the other Normally Conducting for each input channel.) In a typical application, two safety switches (individually mounted) indicate the open or closed status of a gate, moveable guard, or barrier (all called "guards" throughout this document).

Two functions of the Safety Module are:

1. To monitor the contacts and wiring of safety switches for certain failures and to prevent the machine from restarting if the switch or the Module fails, and
2. To provide a reset routine after closing the guard and returning the inputs to their "closed" condition. This reset function may be required by machine safety standards.

The Safety Module monitors each switch for complementary switching; each channel must have one open (OFF) input and one closed (conducting) input at all times. These inputs must always be in opposite states and must switch state within 1 second of each other. Channel 1 has a "guard closed" condition when S11/S13 is closed and S11/S12 is open. Similarly, Channel 2 has a "guard closed" condition when S21/S23 is closed and S21/S22 is open (see Figures 2 and 3). The Safety Module also will detect and properly respond to a short circuit between the channels and a short circuit to other sources of power. The Safety Module will open the safety outputs within 35 milliseconds of the switching of either channel when the guard opens.

When the guard closes, debounce logic in the Safety Module's inputs increases the reliability and repeatability of successfully resetting the Safety Module and reduces the necessity of re-cycling the guard. This feature can result in increased efficiency of the machine, even if the guard is misaligned or vibration is present.

Important ... read this page before proceeding!

The user is responsible for satisfying all local, state, and national laws, rules, codes, and regulations relating to the use of this product and its application. Please direct any questions regarding the use or installation of this product to the factory applications department at the telephone numbers or address shown on back cover.

The user is responsible for making sure that all machine operators, maintenance personnel, electricians, and supervisors are thoroughly familiar with and understand all instructions regarding the installation, maintenance, and use of this product, and with the machinery it controls. The user and any personnel involved with the installation and use of this product must be thoroughly familiar with all applicable ANSI/NFPA standards, some of which are listed below. Banner Engineering Corp. makes no claim regarding a specific recommendation of any organization, the accuracy or effectiveness of any information provided, or the appropriateness of the provided information for a specific application.

Applicable U. S. Standards

ANSI B11 Available from:	Standards for Machine Tools Safety Director AMT – The Association for Manufacturing Technology 7901 Westpark Drive McLean, VA 22102-4269 Tel.: 703-827-2900
ANSI NFPA79 Available from:	Electrical Standard for Industrial Machinery National Fire Protection Association 1 Batterymarch Park, P.O. Box 9101 Quincy, MA 02269-9101 Tel.: 800-344-3555
ANSI/RIA R15.06 Available from:	Safety Requirements for Industrial Robots and Robot Systems Robotic Industries Association 900 Victors Way, P.O. Box 3724 Ann Arbor, MI 48106 Tel.: 734-994-6088

Applicable International Standards

ISO 12100-1 & -2	Safety of Machinery – Basic Concepts, General Principals (EN292-1 & -2) for Design, Part 1: Basic Terminology, Methodology and Part 2: Technical Principles and Specifications
IEC 60204-1	Electrical Equipment of Machines: Part 1: General Requirements
ISO13849-1	Safety of Machinery – Safety Related Parts of Control Systems
ISO13855 (EN999)	Safety of Machinery – The Positioning of Protective Equipment
ISO14119 (EN1088)	Safety of Machinery – Interlocking Devices Associated with Guards
Also, request a type “C” standard for your specific machinery.	
Available from:	Global Engineering Documents 15 Inverness Way East Englewood, CO 80112-5704 Tel.: 800-854-7179

Certificate of Adequacy

This Safety Module data sheet (p/n 60998) satisfies the requirements of Machinery Directive 2006/42/EC, Section 1.7.4 — instructions.

Gate Monitoring Safety Module – Model GM-FA-10J

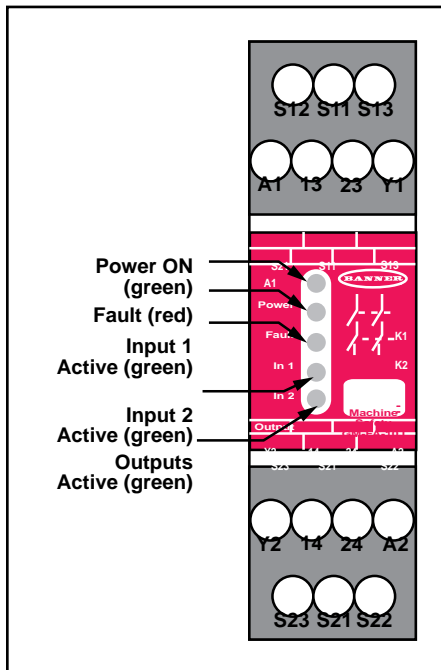

Figure 1. GM-FA-10J features and terminal locations



WARNING . . .

It must not be possible for personnel to reach any hazard point through an opened guard (or any opening) before hazardous machine motion has completely stopped. Please reference the appropriate standards (see page 2) for information on determining safety distances and safe opening sizes for your guarding devices.



WARNING . . . Safety Categories

The level of safety circuit integrity can be greatly impacted by the design and installation of the safety devices and the means of interfacing of those devices. A risk assessment must be performed to determine the appropriate safety circuit integrity level or safety category as described by ISO 13849-1 (EN 954-1) to ensure that the expected risk reduction is achieved and that all relevant regulations and standards are complied with.

Safety Circuit Integrity and ISO 13849-1 Safety Circuit Principles

Safety circuits involve the safety-related functions of a machine that minimize the level of risk of harm. These safety-related functions can prevent initiation, or they can stop or remove a hazard. The failure of a safety-related function or its associated safety circuit usually results in an increased risk of harm.

The integrity of a safety circuit depends on several factors, including fault tolerance, risk reduction, reliable and well-tried components, well-tried safety principles, and other design considerations.

Depending on the level of risk associated with the machine or its operation, an appropriate level of safety circuit performance (i.e., integrity) must be incorporated into its design. Standards that detail safety performance levels include ANSI/RIA R15.06 Industrial Robots, ANSI B11 Machine Tools, OSHA 29CFR1910.217 Mechanical Power Presses, and ISO 13849-1 (EN954-1) Safety-Related Parts of a Control System.

Safety Circuit Integrity Levels

Safety circuits in International and European standards have been segmented into categories, depending on their ability to maintain their integrity in the event of a failure. The most recognized standard that details safety circuit integrity levels is ISO 13849-1 (EN954-1), which establishes five levels: Categories B, 1, 2, 3, and the most stringent, Category 4.

In the United States, the typical level of safety circuit integrity has been called “control reliability.” Control reliability typically incorporates redundant control and self-checking circuitry and has been loosely equated to ISO 13849-1 Categories 3 and 4 (see CSA Z432 and ANSI B11.TR4).

If the requirements described by ISO 13849-1 are to be implemented, a risk assessment must first be performed to determine the appropriate category, in order to ensure that the expected risk reduction is achieved. This risk assessment must also take into account national regulations, such as U.S. control reliability or European “C” level standards, to ensure that the minimum level of performance that has been mandated is complied with.

Fault Exclusion

An important concept within the category requirements of ISO 13849-1 is the “probability of the occurrence of the failure,” which can be decreased using a technique termed “fault exclusion.” The rationale assumes that the possibility of certain well-defined failure(s) can be reduced to a point where the resulting fault(s) can be, for the most part, disregarded—that is, “excluded.”

Fault exclusion is a tool a designer can use during the development of the safety-related part of the control system and the risk assessment process. Fault exclusion allows the designer to design out the possibility of various failures and justify it through the risk assessment process to meet the intent requirements of Category 2, 3 or 4. See ISO 13849-1/2 for further information.

Configuration

The Safety Module may be configured via DIP switches for two-channel (redundant switches on a single guard), or one-channel operation (individual switches on two guards). In two-channel operation, each channel must switch within 3-second simultaneity of the other when the guard closes. If not, the guard must be re-opened and closed until the timing requirement is met. When the guard opens, the two channels operate concurrently (both channels must switch, but without the timing requirement).

In one-channel operation, each channel operates individually, except to reset the device (in which case both guards must be closed). If only one switch is being monitored, the closed input of the unused channel must be jumpered (S11/S13 or S21/S23).

The reset function has two options, selected by DIP switch: Automatic reset or Monitored Manual reset. See Figure 7 for configuration information.

Gate Monitoring Safety Module – Model GM-FA-10J

The reset input also can be used for an External Device Monitoring (EDM) circuit. The EDM circuit consists of a normally closed, force-guided contact from each device being controlled by the Safety Module, all wired in series with the Reset button (if used) and terminated at terminals Y1 and Y2. See Figure 6 for further information.

The output of the Safety Module consists of two redundant output switching channels, each of which is the series connection of two forced-guided relay contacts (K1 and K2 in Figure 6). Each of the switching outputs is rated for up to 250V ac at up to 6 amps.

Safety Switch Requirements

The following general requirements and considerations apply to the installation of interlocked gates and guards for the purpose of safeguarding. In addition, the user must refer to the relevant regulations and be sure to comply with all necessary requirements.

Hazards guarded by the interlocked guard must be prevented from operating until the guard is closed; a stop command must be issued to the guarded machine if the guard opens while the hazard is present. Closing the guard must not, by itself, initiate hazardous motion; a separate procedure must be required to initiate the motion. The safety switches must not be used as a mechanical or end-of-travel stop.

The guard must be located an adequate distance from the danger zone (so the hazard has time to stop before the guard is opened sufficiently to provide access to the hazard), and it must open either laterally or away from the hazard, not into the safeguarded area. The guard also should not be able to close by itself and activate the interlocking circuitry. The installation must prevent personnel from reaching over, under, around or through the guard to the hazard. Any openings in the guard must not allow access to the hazard (see the appropriate standard). The guard must be strong enough and designed to protect personnel and contain hazards within the guarded area that can be ejected, dropped or emitted by the machine.

The safety switches, actuators, sensors and magnets used with the Safety Module must be designed and installed so that they cannot be easily defeated. They must be mounted securely, so that their physical position can not shift, using reliable fasteners that require a tool to remove. Mounting slots in the housings are for initial adjustment only; final mounting holes must be used for permanent location.

Coded Magnetic Safety Switches: Similar to positive-opening safety switches, coded magnetic switches used with the Safety Module must provide one normally closed contact and one normally open contact (typically a four-wire switch). (See Banner Safety Catalog or page 15 for more information.) The sensor and its magnet must be mounted a minimum distance of 15 mm (0.6) from any magnetized or ferrous materials for proper operation. If either the sensor or magnet is mounted on a material that can be magnetized (a ferrous metal, such as iron), the switching distance will be affected. Although the sensor and magnet are coded to minimize the possibility of false actuation, they should not be used within known fields of high-level electromagnetic radiation.

Depending on the model of sensor and magnet used, the installation must be designed to provide the correct direction of approach (see page 17). The speed of approach must be fast enough to meet the simultaneity-monitoring period of 1.0 second, approximately equal to or greater than 0.1 m (4) per second. If the simultaneity requirement is not met, the Safety Module can not be reset and will not close its safety output contacts.

Positive-Opening Interlocking Switches: Safety interlock switches used with the Safety Module must satisfy several requirements. Each switch must provide electrically isolated contacts: at minimum, one normally closed (N.C.) contact or normally conducting source and one normally open (N.O.) contact or normally OFF source to interface with the Module.

The contacts must be of “positive-opening” design, with one or more normally closed contacts rated for safety. Positive-opening operation causes the switch to be forced open, without the use of springs, when the switch actuator is disengaged or moved from its home position (see the Banner Safety Catalog for examples). In addition, the switches must be mounted in a “positive mode,” to move/disengage the actuator from its home position and open the normally closed contact, when the guard opens.

Gate Monitoring Safety Module – Model GM-FA-10J

Switch Hookups, Typical Applications

Requirements vary widely for the level of control reliability or safety category (per ISO 13849) in the application of interlocked guards. While Banner Engineering always recommends the highest level of safety in any application, it is the responsibility of the user to safely install, operate and maintain each safety system and comply with all relevant laws and regulations. The applications shown in Figures 2, 3, and 4 meet or exceed the requirements for control reliability and Safety Category 3 or 4, per ISO 13849 (EN954-1).

Mechanical Installation

Route the switch cable to the Safety Module location. The Safety Module is not designed for exposed wiring; house it in an enclosure with a NEMA 3 (or IEC IP54) rating, or better. The Safety Module may be mounted directly onto standard 35 mm DIN rail.

Heat Dissipation Considerations

For reliable operation, the user must ensure that the operating specifications are not exceeded. The enclosure must provide adequate heat dissipation, so that the air closely surrounding the Module does not exceed the maximum operating temperature stated in the Specifications. Methods to reduce heat build-up include venting, forced airflow (e.g., exhaust fans), adequate enclosure exterior surface area, and spacing between modules and other sources of heat.

Electrical Installation

Each Safety Module is powered by 24V ac/dc (at less than 150 mA). The Safety Module, in turn, supplies power to each switch.

It is not possible to give exact wiring instructions for a Safety Module which interfaces to a multitude of machine control configurations. The following guidelines are general in nature.

The Safety Module has no delay function. Its output relay contacts open within 35 milliseconds after a safety input opens. This classifies the Safety Module as functional stop “Category 0”, as defined by ANSI NFPA 79 and IEC/EN 60204-1.

WARNING . . . Shock Hazard

Always disconnect power from the Safety Module and all power from the machine being controlled before making any connections or replacing any component. Electrical installation and wiring must be made by qualified personnel and must comply with the NEC (National Electrical Code), ANSI NFPA79 or IEC 60204-1, and all applicable local standards and codes.

Connection of Power to the Safety Module

The Safety Module requires a 24V ac/dc supply voltage (see Specifications). Use extreme caution whenever installing ac power. Use a minimum of 16 to 18 AWG wire for power and output connections. Use a minimum of 20 AWG wire for all other terminal connections. A hand-operated supply disconnect and over-current protection (e.g., a circuit breaker) must be provided per ANSI NFPA79 and IEC/EN60204-1.

See Figures 2 through 6 for connection of safety switches.

Monitoring Series-Connected Safety Switches

When monitoring two individually mounted safety switches (as shown in Figures 2, 3, and 4), a faulty switch will be detected if it fails to switch as the guard opens. In this case, the Gate Monitor Module will de-energize its output relays and disable its reset function until the input requirements are met (i.e., the faulty switch is replaced). However, when a series of interlocking safety switches is monitored by a single Safety Module, the failure of one switch in the system may be masked or not detected at all (refer to Figures 5 and 6).

Series-connected interlock switch circuits do not meet ISO 13849 (EN954-1) Safety Category 4 and may not meet Control Reliability requirements because of the potential for an inappropriate Gate Monitor reset or a potential loss of the safety stop signal. A multiple connection of this type should not be used in applications where loss of the safety stop signal or an inappropriate reset can lead potentially to serious injury or death. The following two scenarios assume two positive-opening safety switches on each guard:

Gate Monitoring Safety Module – Model GM-FA-10J

1. **Masking of a failure.** If a guard is opened but a switch fails to open, the redundant safety switch will open and cause the Safety Module to de-energize its outputs. If the faulty guard is then closed, both Safety Module input channels also close, but because one channel did not open, the Safety Module will not reset. However, if the faulty switch is not replaced and a second “good” guard is cycled (opening and then closing both of the Module’s input channels), the Module considers the failure to be corrected. With the input requirements apparently satisfied, the Module allows a reset. This system is no longer redundant and, if the second switch fails, may result in an unsafe condition (i.e., the accumulation of faults results in the loss of the safety function).
2. **Non-detection of a failure.** If a good guard is opened, the Safety Module de-energizes its outputs (a normal response). But if a faulty guard is then opened and closed before the good guard is re-closed, the failure on the faulty guard is not detected. This system is no longer redundant and may result in a loss of safety if the second safety switch fails to switch when needed.

The systems in either scenario do not inherently comply with the safety standard requirements of detecting single faults and preventing the next cycle. In multiple-guard systems using series-connected safety switches, it is important to periodically check the functional integrity of each interlocked guard individually. **Operators, maintenance personnel, and others associated with the operation of the machine must be trained to recognize such failures and be instructed to correct them immediately.**

Open and close each guard separately while verifying that the Gate Monitor outputs operate correctly throughout the check procedure. Follow each gate closure with a manual reset, if needed. If a contact set fails, the Safety Module will not enable its reset function. If the Safety Module does not reset, a switch may have failed; that switch must be immediately replaced.

This check must be performed and all faults must be cleared, at a minimum, during periodic checkouts. **If the application can not exclude these types of failures and such a failure could result in serious injury or death, then the series connection of safety switches must not be used.**

Connection to the Guarded Machine

The machine interface hookup diagram (Figure 7) shows a generic connection of the Module’s two redundant output circuits to machine primary control elements MPCE1 and MPCE2. A machine primary control element is an electrically powered device, external to the Module, which stops the guarded machinery by immediately removing electrical power to the machine and (when necessary) by applying braking to dangerous motion. The stop is accomplished by removing power to the actuator coil of either MPCE.

To satisfy the Safety Category 4 requirements of ISO 13849 (EN 954-1), each MPCE must offer a normally closed, forced-guided monitor contact. One normally closed monitor contact from each MPCE is wired in series to the Y1-Y2 feedback/reset input (see Figure 7). In operation, if one of the switching contacts of either MPCE fails in the shorted condition, the associated monitor contact will remain open, preventing the reset of the Module.

External Device Monitoring

To satisfy the requirements of Control Reliability (OSHA and ANSI) and Category 3 and 4 of ISO 13849-1 (EN 954-1), the machine primary control elements (MPCEs) must each offer a normally closed, forced-guided (mechanically linked) monitor contact. Connect one normally closed monitor contact from each master stop control element in series to Y1 and Y2 (see hookup drawings).

In operation, if one of the switching contacts of either MPCE fails in the energized condition, the associated monitor contact will remain open. Therefore, it will not be possible to reset the Safety Module. If no MPCE-monitor contacts are monitored, a jumper must be installed between terminals Y1 and Y2 (dotted line), as shown in the hookup drawings. **It is the user’s responsibility to ensure that any single failure will not result in a hazardous condition and will prevent a successive machine cycle.**



WARNING . . . Multiple Switching Devices

Whenever two or more switches are connected to the same Safety Module:

- Contacts of the corresponding pole of each switch must be connected together in series. Never connect the contacts of multiple emergency-stop switches in parallel to one Module. Such a parallel connection defeats the switch contact monitoring ability of the Module and creates an unsafe condition which could result in serious injury or death.
- Each switch must be individually actuated (engaged), then re-armed and the Safety Module reset. This allows the Module to check each switch and its wiring to detect faults.

Failure to test each switch individually in this manner could result in undetected faults and create an unsafe condition which could result in serious injury or death. This check must be performed during periodic checkouts.

Gate Monitoring Safety Module - Model GM-FA-10J

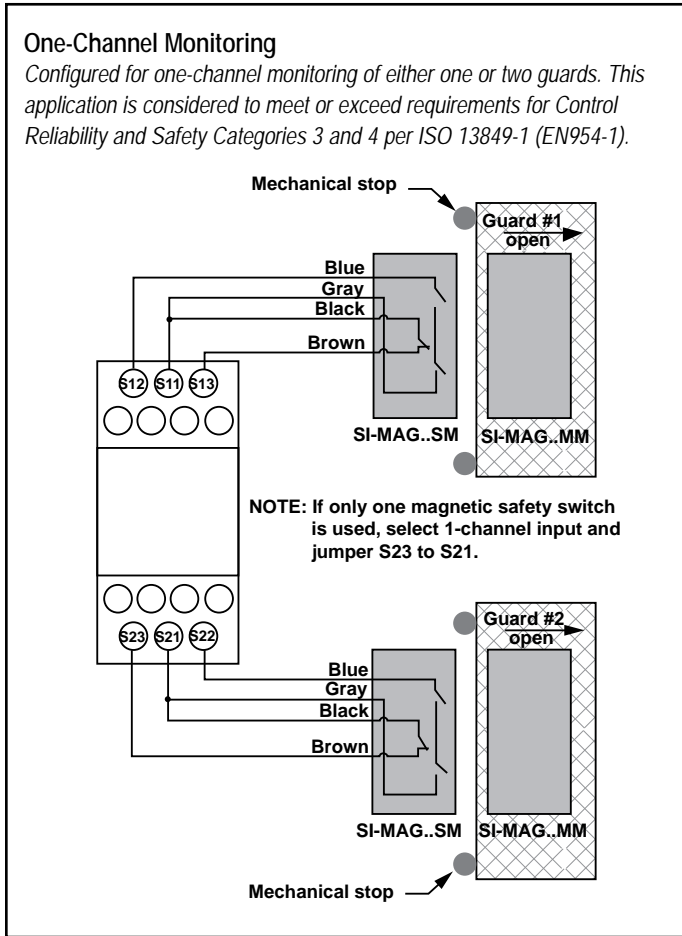

Figure 2. Hookup to two 4-wire coded magnetic safety switches

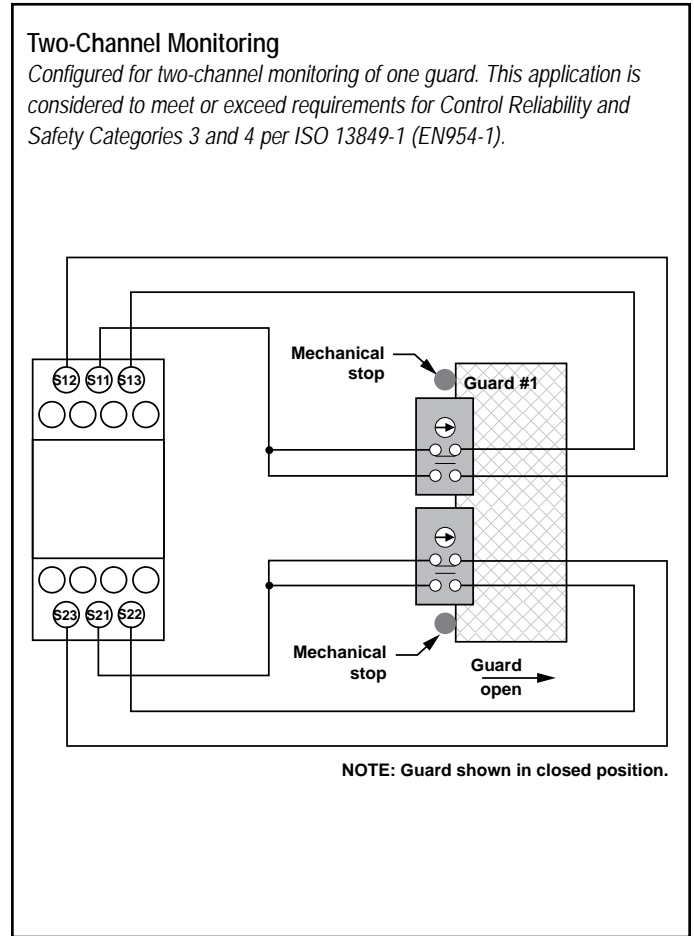

Figure 3. Hookup to two positive-opening safety interlock switches

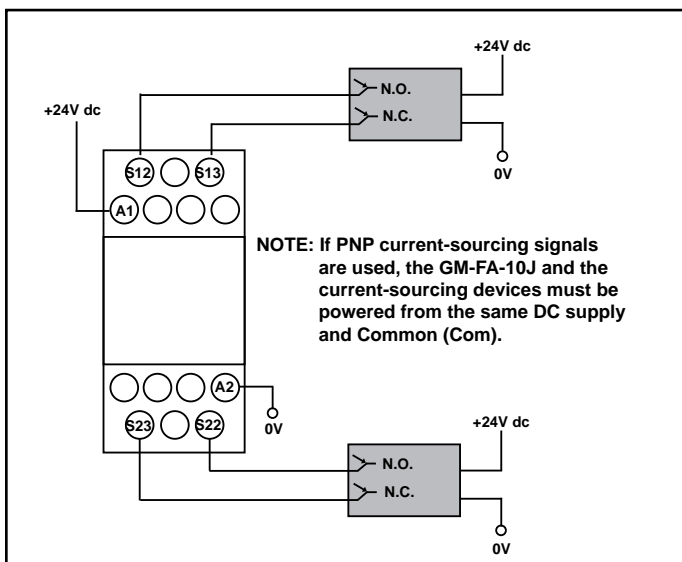

Figure 4. Hookup to two complementary current-sourcing PNP devices

Gate Monitoring Safety Module - Model GM-FA-10J

One-Channel Monitoring

Configured for one-channel monitoring of multiple guards with single switches at each guard (see Warning). Up to 10 Banner magnetic switches may be connected to each channel in this series/parallel method.

WARNING . . . Not a Safety Category 4 Application

When monitoring multiple guards with a series connection of multiple safety interlock switches, a single failure may be masked or not detected at all.

When such a configuration is used, procedures must be performed regularly to verify proper operation of each switch. See "Monitoring Series-Connected Safety Switches" (page 6) for more information.

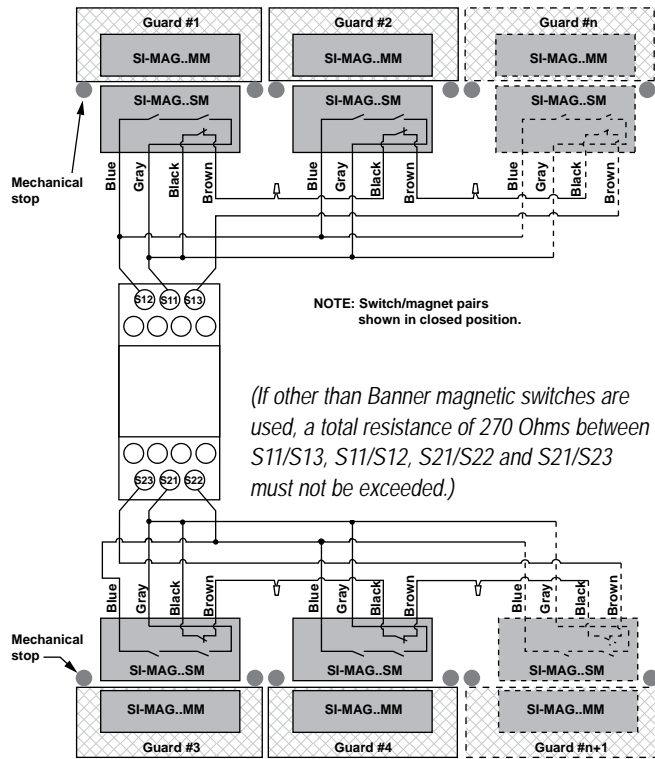

Figure 5. Alternate hookup for one-channel monitoring of multiple guards

Two-Channel Monitoring

Configured for two-channel monitoring of multiple guards with two safety switches mounted individually on each guard (see Warning).

The number of mechanical switches is limited by the max. resistance of 270 ohm between S11/S13, S11/S12, S21/S22 and S21/S23. The total resistance is calculated by adding the resistance of all guard switch contacts and the resistance of the cables that connect the switches and the switches to the module.

WARNING . . . Not a Safety Category 4 Application

When monitoring multiple guards with a series connection of multiple safety interlock switches, a single failure may be masked or not detected at all.

When such a configuration is used, procedures must be performed regularly to verify proper operation of each switch. See "Monitoring Series-Connected Safety Switches" (page 6) for more information.

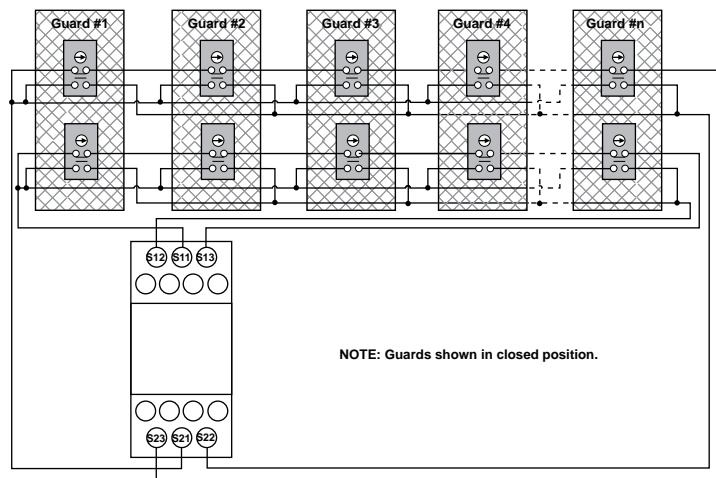

Figure 6. Alternate hookup for two-channel monitoring of multiple guards

Gate Monitoring Safety Module – Model GM-FA-10J

Overvoltage Category II and III Installations (EN 50178 and IEC 60664-1)

The Safety Module is rated for Overvoltage Category III when voltages of 1V to 150V ac/dc are applied to the output relay contacts. It is rated for Overvoltage Category II when voltages of 151V to 250V ac/dc are applied to the output relay contacts and no additional precautions are taken to attenuate possible overvoltage situations in the supply voltage. The Module can be used in an Overvoltage Category III environment (with voltages of 151V to 250V ac/dc) if care is taken either to reduce the level of electrical disturbances seen by the Module to Overvoltage Category II levels by installing surge suppressor devices (e.g., arc suppressors), or to install extra external insulation in order to isolate both the Safety Module and the user from the higher voltage levels of a Category III environment.

For Overvoltage Category III installations with applied voltages from 151V to 250V ac/dc applied to the output contact(s): the Safety Module may be used under the conditions of a higher overvoltage category where appropriate overvoltage reduction is provided. Appropriate methods include:

- An overvoltage protective device
- A transformer with isolated windings
- A distribution system with multiple branch circuits (capable of diverting energy of surges)
- A capacitance capable of absorbing energy of surges
- A resistance or similar damping device capable of dissipating the energy of surges

When switching inductive ac loads, it is good practice to protect the Safety Module outputs by installing appropriately-sized arc suppressors. However, if arc suppressors are used, they must be installed across the load being switched (e.g., across the coils of external safety relays), and never across the Safety Module's output contacts (see Warning on page 7).

WARNING . . . Interfacing MPCEs

NEVER wire an intermediate device(s) (e.g., PLC, PES, PC), between the Safety Module outputs and the machine primary control element (MPCE) it switches, in such a manner that in the event of a failure there is the loss of the safety stop command, OR in such a manner that the safety function can be suspended, overridden, or defeated, unless accomplished with the same or greater degree of safety. Whenever forced-guided, mechanically linked relays are added as intermediate switching devices, a normally closed forced-guided monitor contact from each relay must be added to the series feedback loop between Safety Module terminals Y1 and Y2.

WARNING . . . Wiring of Arc Suppressors

If arc suppressors are used, they MUST be installed as shown across the coil of the machine primary control elements (MPCE1 and MPCE2). NEVER install suppressors directly across the output contacts of the Safety Module. It is possible for suppressors to fail as a short circuit. If installed directly across the output contacts of the Safety Module, a short-circuited suppressor will create an unsafe condition which could result in serious injury or death.

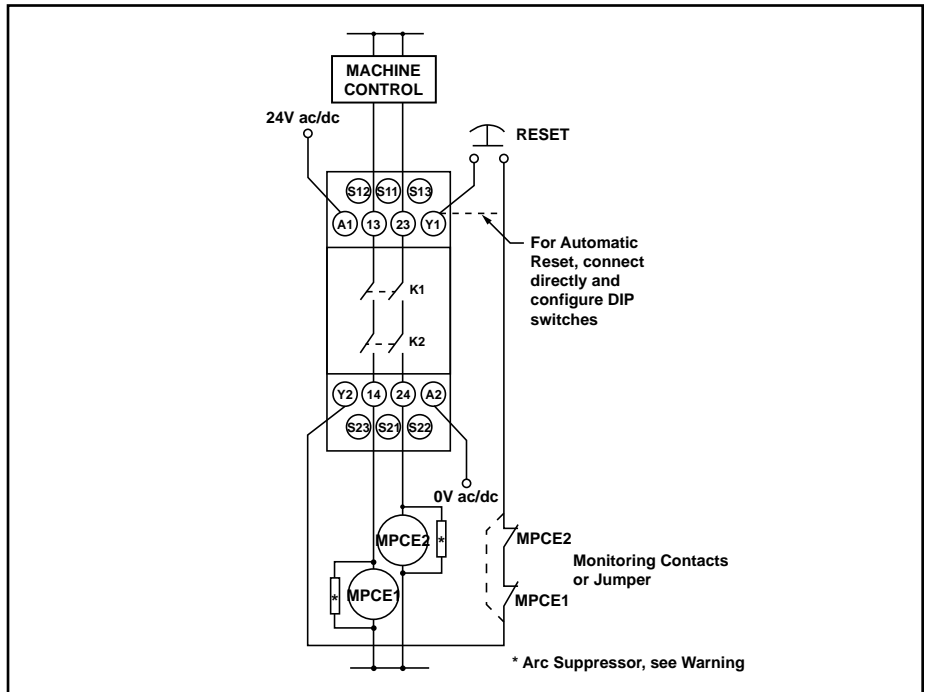

Gate Monitoring Safety Module – Model GM-FA-10J

Configuration

Manual Reset and Reset Switch Connection

The reset switch must be capable of reliably switching 15 to 30V dc at 5 to 50 mA. As shown in Figure 7, the reset switch connects between terminals Y1 and Y2 of the Module. The reset switch must be located outside of – and not accessible from – the area of dangerous motion, and it must be positioned so the switch operator can see all areas of dangerous motion during the reset procedure (see Warning).

To configure the Module for Manual Reset, set switches S1.2 and S2.2 in banks A and B to OFF. The reset switch may be any mechanical normally open switch, but should be a momentary switch or a two-position keyed switch. To reset the Module, both guards must be closed, at which time the output LED will flash (signaling that the reset switch must be cycled). This action is a monitored manual reset (open-closed-open), where the “closed” phase is approximately 0.25 to 2 seconds long.

Automatic Reset Mode

To configure the Module for Automatic Reset, set switches S1.2 and S2.2 in Banks A and B to ON. If no MPCE contacts are monitored, install a jumper between terminals Y1 and Y2 (see Figure 7). The Safety Module will reset (and its outputs will energize) as soon as the guards return to their closed position.

Automatic Reset is useful for some automated processes. However, if Automatic Reset is used, an alternate means must be provided to prevent resumption of hazardous machine motion until an alternate reset procedure is performed. The alternate means must include a Reset switch, located outside the area of dangerous motion, and positioned so that the switch operator can see all areas of dangerous motion during the reset procedure.

1-Channel or 2-Channel Input

The Safety Module may be configured for 1-channel (“single channel”) or 2-channel (“dual channel”) operation by setting DIP switches S1.1 and S2.1 in Banks A and B. In 1-channel operation (S1.1 and S2.1 – ON), the input channels function independently. The two guards can be monitored individually, but both channels must be in the closed position for the Safety Module to be reset.

In 2-channel operation (S1.1 and S2.1 – OFF) the input channels must function together. Both channels must switch within a 3-second simultaneity of the other when the guard closes. If not, the guard must be re-opened and closed until the timing requirement is met. When the guard opens, the channels function concurrently (both must open, but without the timing requirement).

In either configuration, the “closed” inputs of each channel must be closed before the Safety Module can be reset (continuity S11 to S13 and S21 to S23). If in 1-channel mode and monitoring only one switch, a jumper must be installed at the unused input (e.g., S21 to S23; see Figure 2).

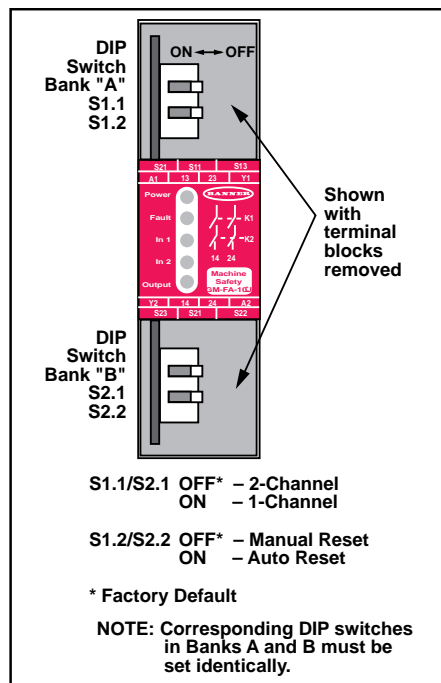

Figure 8. DIP switch configuration settings for reset mode and 1- or 2-channel operation

WARNING . . . Reset Routine Required

U.S. and international standards require that a reset routine be performed after clearing the cause of a stop condition (e.g., arming an E-stop button, closing an interlocked guard, etc.). Allowing the machine to restart without actuating the normal start command/device can create an unsafe condition which could result in serious bodily injury or death.

WARNING . . . Reset Switch Location

The reset switch must be accessible only from outside, and in full view of, the hazardous area. Reset switches must also be out of reach from within the safeguarded space, and must be protected against unauthorized or inadvertent operation (e.g., through the use of rings or guards). If any areas are not visible from the reset switch(es), additional means of safeguarding must be provided. Failure to do so could result in serious bodily injury or death.

Gate Monitoring Safety Module – Model GM-FA-10J

CAUTION . . . Disconnect Power Prior to Checkout

Before performing the initial checkout procedure, make certain all power is disconnected from the machine to be controlled. Dangerous voltages may be present along the E-stop Safety Module wiring barriers whenever power to the machine control elements is ON. Exercise extreme caution whenever machine control power is or may be present. Always disconnect power to the machine control elements before opening the enclosure housing of the Safety Module.

WARNING . . . Multiple Safety Devices

When two or more safety devices are used, each device must be individually actuated, causing a STOP or open-contact condition, then reset/rearmed and the Safety Module reset (if using manual reset mode). This allows the monitoring circuits to check each device and its wiring to detect faults. Failure to test each device in this way could result in undetected faults and create an unsafe condition. This could result in serious bodily injury or death.

To remove a terminal block, insert a small screwdriver into the slot as shown, and pry to loosen.

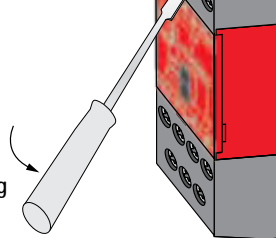

When reinserting the block, take care to slide the dovetail on the terminal block into the slot on the frame.

Figure 9. Removal of terminal blocks

Initial Checkout Procedure

1. Remove power from the machine primary control elements (MPCEs).
2. Close all monitored guards. If the Module is wired to 1-channel input, the second input (S21/S23 or S11/S13) must be jumpered if unused.
3. Apply input power (only) to the Gate Monitor Module at terminals A1 and A2 (see Figure 7). The following LEDs should come ON:
 - Power
 - Input 1
 - Input 2

If the Power LED comes ON, but either or both Input LEDs are *not* ON, disconnect input power and check the wiring of the connected switch(es) and/or the jumper. Check if the jumper is installed correctly on the unused input. Return to step 2 after the cause of the problem has been corrected.

4. If the Module is set to 1-channel operation: After the Power, Input 1, and Input 2 LEDs all are ON, open and close all connected guards one at a time. When each individual guard opens, the corresponding Input LED must turn OFF, and when the guard closes its LED must come ON again.

If the Module is set to 2-channel operation: After the Power, Input 1, and Input 2 LEDs all are ON, open the guard; both switches must open within 3 seconds, and both Input LEDs must turn OFF. If the red Fault LED comes ON, simultaneity between the switches or within one switch (between its NO and NC contacts) was not met. Check all wiring and the switches.

If the Module is set to Auto Reset: (Y1/Y2 closed and DIP switches set to Auto Reset), the output LED will come ON as soon as both Input LEDs are ON (output contacts 13/14 and 23/24 close).

If the Module is set to Manual Monitored Reset: the Output LED should come ON only if Input 1 and 2 LEDs are ON and the Reset button connected to Y1 and Y2 went from open to closed and back to open position.

5. Repeat step 4 individually for each guard that is being monitored.
6. Close the guard. Apply power to the machine control elements and perform the Periodic Checkout Procedure on page 12.

NOTE: Make sure that both Input 1 and 2 LEDs are ON *only when ALL connected guards are closed*. If the guards are closed and the Input LEDs are OFF, the guard switches may be wired incorrectly, which could reset the Module inappropriately (safety output contacts close as soon as one of the connected guards opens).

Do not continue operation until all checks are completed and all problems are corrected. See the Warning on page 12, and Repair and Troubleshooting on pages 18 and 19 for further information.

Gate Monitoring Safety Module – Model GM-FA-10J

Periodic Checks

At each shift change or machine setup, a Designated Person* should do the following checks on all safety switches:

1. Breakage or damage of the switch, sensor, actuator, or magnet.
2. Good alignment between the switch and actuator or sensor and magnet.
3. Confirmation that the switches are not being used as an end-of-travel stop.
4. Loosening of the mounting hardware.
5. Verification that it is not possible to reach any hazard point through an opened guard (or any opening) before hazardous machine motion stops completely.
6. Open and close each guard separately while verifying that the Gate Monitor outputs operate correctly throughout the check procedure. Follow each gate closure with a manual reset, if needed. If a contact set fails, the Safety Module will not enable its reset function. If the Safety Module does not reset, a switch may have failed; that switch must be immediately replaced.

In addition, a Qualified Person* should do the following on a periodic schedule (determined by the user, based upon the severity of the environment and the frequency of switch actuations):

1. Inspect the electrical wiring for continuity and damage.
2. Confirm that wiring conforms to the instructions given in this installation manual.

Do not continue operation until all checks are completed and all problems are corrected. See Repair and Troubleshooting on pages 18 and 19 for further information.

* A Designated Person is identified in writing by the employer as being appropriately trained to perform a specified checkout procedure. A Qualified Person possesses a recognized degree or certificate or has extensive knowledge, training, and experience to be able to solve problems relating to safety switch installation.









WARNING . . . Do Not Use Machine Until System Is Working Properly

If all of these checks cannot be verified, do not attempt to use the guarded machine until the defect or problem has been corrected.



Attempts to use the guarded machine under such conditions could result in serious bodily injury or death.

Gate Monitoring Safety Module – Model GM-FA-10J

Specifications

Supply Voltage and Current	24V dc $\pm 15\%$ @ 150 mA (SELV-rated supply according to EN IEC 60950, NEC Class 2) 24V ac $\pm 15\%$ @ 150 mA, 50-60 Hz $\pm 5\%$ (NEC Class 2-rated transformer) Power consumption: approx. 3 VA / 3 W To comply with UL and CSA standards, the isolated secondary power supply circuit in the installation must incorporate a method to limit the overvoltage to 0.8 kV.												
Supply Protection Circuitry	Protected against transient voltages and reverse polarity												
Overvoltage Category	Output relay contact voltage of 1V to 150V ac/dc: Category III Output relay contact voltage of 151V to 250V ac/dc: Category II (Category III, if appropriate overvoltage reduction is provided, as described on page 9.)												
Pollution Degree	2												
Output Configuration	<p>Each normally open output channel is a series connection of contacts from two forced-guided (mechanically linked) relays, K1-K2. Contacts: AgNi, 5 μm gold-plated Low Current Rating: The 5 μm gold-plated contacts allow the switching of low current/low voltage. In these low-power applications, multiple contacts can also be switched in series (e.g., “dry switching”). To preserve the gold plating on the contacts, do not exceed the following max. values at any time:</p> <table border="0"> <tr> <td>Min. voltage: 1V ac/dc</td> <td>Max. voltage: 60V</td> </tr> <tr> <td>Min. current: 5 mA ac/dc</td> <td>Max. current: 300 mA</td> </tr> <tr> <td>Min. power: 5 mW (5 mVA)</td> <td>Max. power: 7 W (7 VA)</td> </tr> </table> <p>High Current Rating: If higher loads must be switched through one or more of the contacts, the minimum and maximum values of the contact(s) changes to:</p> <table border="1"> <tr> <td rowspan="2">  </td> <td> Minimum: Voltage: 15V ac/dc Current: 30 mA ac/dc Power: 0.45 W (0.45 VA) </td> <td> Maximum: 250V ac / 24V dc, 6 A resistive B300, R300 per UL508 </td> </tr> <tr> <td>  </td> <td> Minimum: Voltage: 15V ac/dc Current: 30 mA ac/dc Power: 0.45 W (0.45 VA) </td> <td> Maximum: 250V ac / 24V dc, 6 A resistive IEC 60947-5-1: AC15: 230V ac, 3 A; DC-13: 24V dc, 2 A </td> </tr> </table> <p>Mechanical life: 50,000,000 operations Electrical life (switching cycles of the output contacts, resistive load): 150,000 cycles @ 900 VA; 1,000,000 cycles @ 250 VA; 2,000,000 cycles @ 150 VA; 5,000,000 cycles @ 100 VA NOTE: Transient suppression is recommended when switching inductive loads. Install suppressors across load. Never install suppressors across output contacts (see Warning, page 9).</p>	Min. voltage: 1V ac/dc	Max. voltage: 60V	Min. current: 5 mA ac/dc	Max. current: 300 mA	Min. power: 5 mW (5 mVA)	Max. power: 7 W (7 VA)		Minimum: Voltage: 15V ac/dc Current: 30 mA ac/dc Power: 0.45 W (0.45 VA)	Maximum: 250V ac / 24V dc, 6 A resistive B300, R300 per UL508		Minimum: Voltage: 15V ac/dc Current: 30 mA ac/dc Power: 0.45 W (0.45 VA)	Maximum: 250V ac / 24V dc, 6 A resistive IEC 60947-5-1: AC15: 230V ac, 3 A; DC-13: 24V dc, 2 A
Min. voltage: 1V ac/dc	Max. voltage: 60V												
Min. current: 5 mA ac/dc	Max. current: 300 mA												
Min. power: 5 mW (5 mVA)	Max. power: 7 W (7 VA)												
	Minimum: Voltage: 15V ac/dc Current: 30 mA ac/dc Power: 0.45 W (0.45 VA)	Maximum: 250V ac / 24V dc, 6 A resistive B300, R300 per UL508											
		Minimum: Voltage: 15V ac/dc Current: 30 mA ac/dc Power: 0.45 W (0.45 VA)	Maximum: 250V ac / 24V dc, 6 A resistive IEC 60947-5-1: AC15: 230V ac, 3 A; DC-13: 24V dc, 2 A										
Output Response Time	35 ms max.												
Input Requirements	Each switch or sensor must have a normally closed contact and a normally open contact capable of switching 20 to 50 mA @ 15 to 30V dc. Reset switch: 20 mA @ 12V dc, hard contact only Max. external resistance between terminals S11/S12, S11/S13, S21/S22 and S21/S23: 270 ohms each.												
Simultaneity Monitoring	2-Channel operation: 3 seconds 1-Channel operation: infinite												
Status Indicators	1 red LED: Fault (see “Troubleshooting,” page 18) 4 green LEDs: Power – power is supplied to Safety Module Channel 1 – inputs satisfied (guard closed) Channel 2 – inputs satisfied (guard closed) Output – K1 and K2 energized, safety outputs closed												
Construction	Polycarbonate housing. Rated IEC IP20												
Mounting	Mounts to standard 35 mm DIN rail track. Safety Module must be installed inside an enclosure rated NEMA 3 (IEC IP54), or better.												

Gate Monitoring Safety Module - Model GM-FA-10J

Vibration Resistance	10 to 55 Hz @ 0.35 mm displacement per IEC 60068-2-6
Operating Conditions	Temperature: 0° to +50°C (+32° to 122°F) Maximum Relative Humidity: 90% @ +50°C (non-condensing)
Dimensions	See Figure 10.
Design Standards	CE: Cat. 4 PL e, per EN ISO 13849-1; SIL 3 per IEC 61508 and IEC 62061
Certifications	  Emergency Stop Device 2911

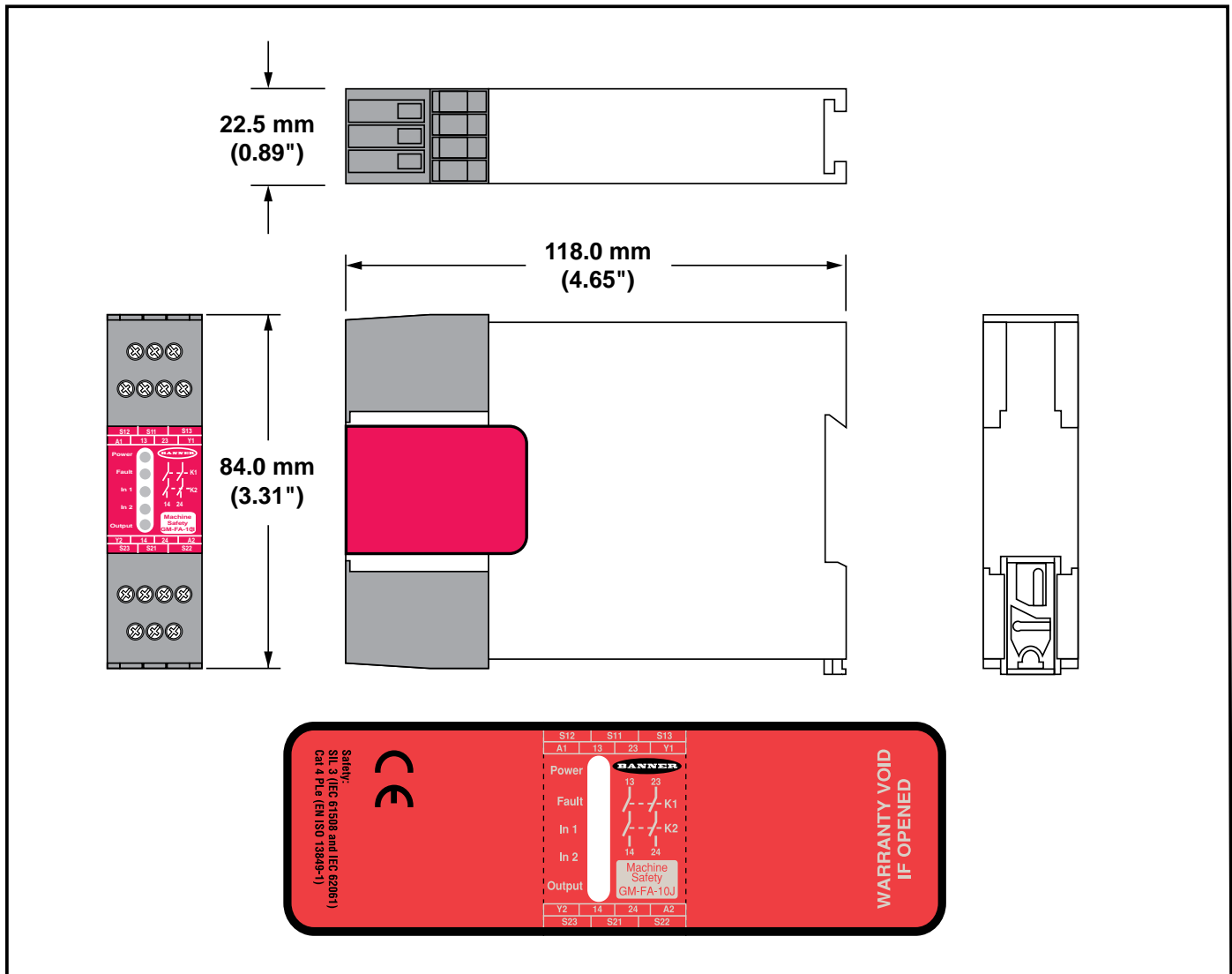





Figure 10. Dimensions and label

Gate Monitoring Safety Module – Model GM-FA-10J

Accessories

Magnetic Switch Models

Magnet / Sensor Pair	Magnet Sensor*	Coded Magnet	Sensor Cable	Switching Distance	
				Min. ON	Max. OFF
	SI-MAG1SM SI-MAG1SMCO†	SI-MAG1MM SI-MAG1MM90††	3 m (10')	3 mm (0.12")	14 mm (0.55")
		SI-MAG1MMHF		8 mm (0.31")	16 mm (0.63")
	SI-MAG2SM	SI-MAG2MM		4 mm (0.16")	8 mm (0.32")
	SI-MAG3SM	SI-MAG3MM	3 mm (0.12")	7 mm (0.28")	

* 9 m (30') cables are available for magnet sensors by adding suffix "w/30" to the model number (e.g., SI-MAG1SM w/30).

† Cable opposite see Figure 11b, page 16)

†† 90° orientation (see Figure 14a, page 17)

Magnetic Switch Specifications

Switching Elements	Three pole-stable reed switches
Repeat Switching Accuracy	±0.1 mm (±0.004")
Construction	Epoxy-encapsulated circuit in polyamide housing
Environmental Rating	NEMA 4X, IEC IP67
Switching Capacity	30V dc max @ 0.25W (27 Ω fuse resistor in-line, each channel)
Operating Temperature	-5° to +70°C (+23° to +158°F)
Connections	Integral PVC-jacketed 3 m (10') 4-wire cable. Cable O.D. is 5 mm (0.2"). Wires are 24 AWG (0.25 mm ²).
Hardware	All mounting hardware is supplied by user. Use of permanent fasteners or locking hardware is recommended to prevent loosening or displacement of the actuator and switch body. Mounting holes in the magnet and sensor accept M4 (#6) hardware (see Figures 11, 12, and 13).
Application Note	The sensor/magnet pair must be mounted a minimum distance of 15 mm (0.6") from any magnetized or ferrous materials. Multiple SFA-IMB1 (used with SI-MAG1..) and SFA-IMB2 (used with SI-MAG2..) can be used as spacers.

Gate Monitoring Safety Module - Model GM-FA-10J

Magnetic Switch Dimensions

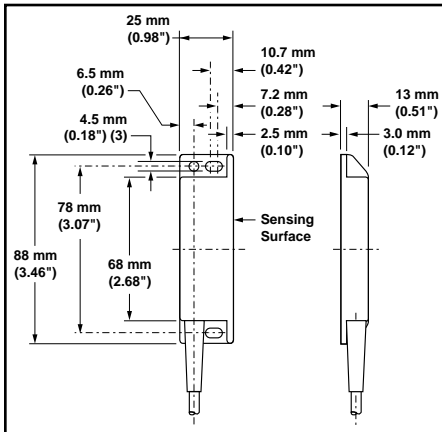

Figure 11a. SI-MAG1SM Sensor

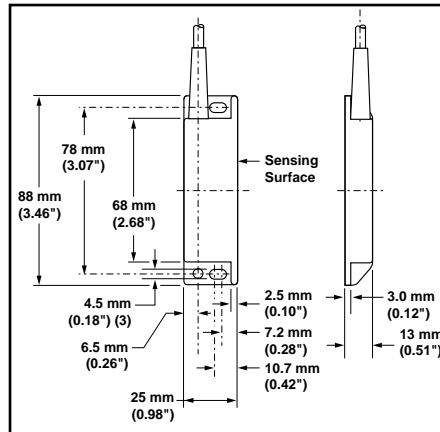

Figure 11b. SI-MAG1SMCO Sensor

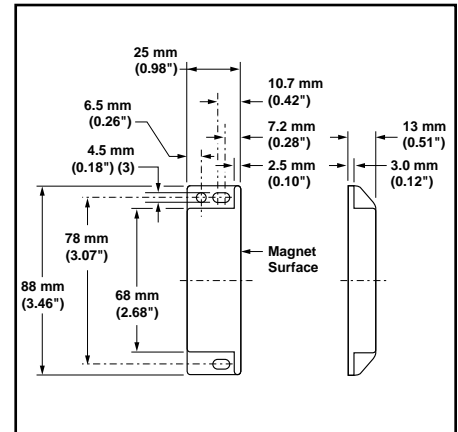

Figure 11c. SI-MAG1MM/MM90/MMHF Magnet

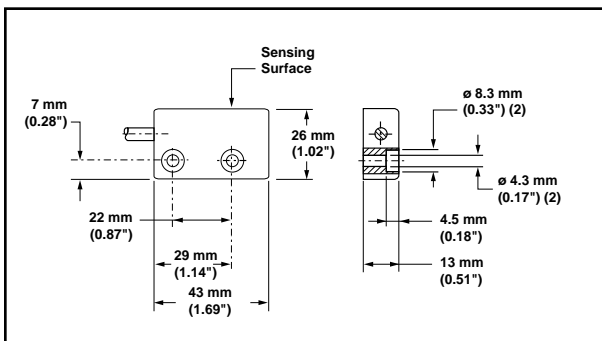

Figure 12a. SI-MAG2SM Sensor

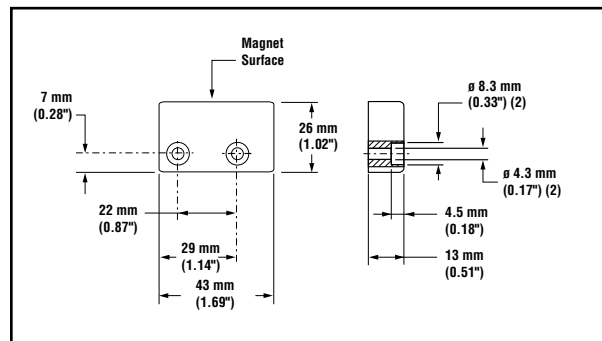

Figure 12b. SI-MAG2MM Magnet

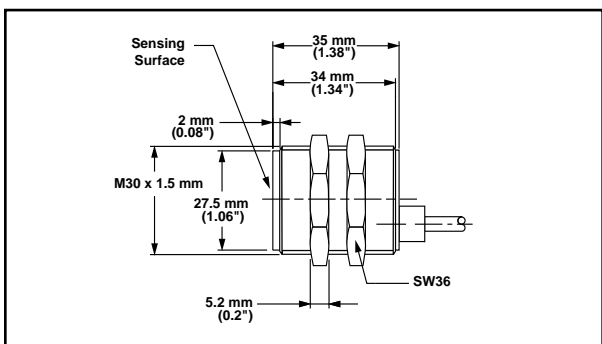

Figure 13a. SI-MAG3SM Sensor

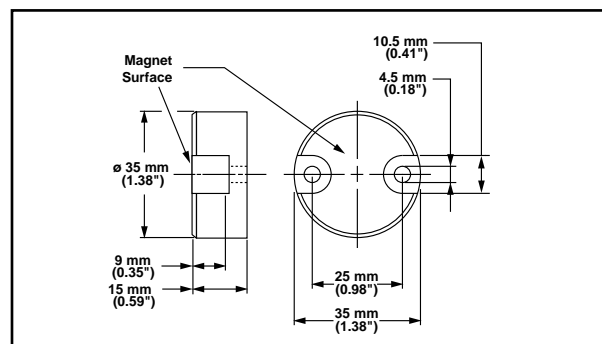

Figure 13b. SI-MAG3MM Magnet

“Direction of Approach” Options for Sensor/Magnet Pairs

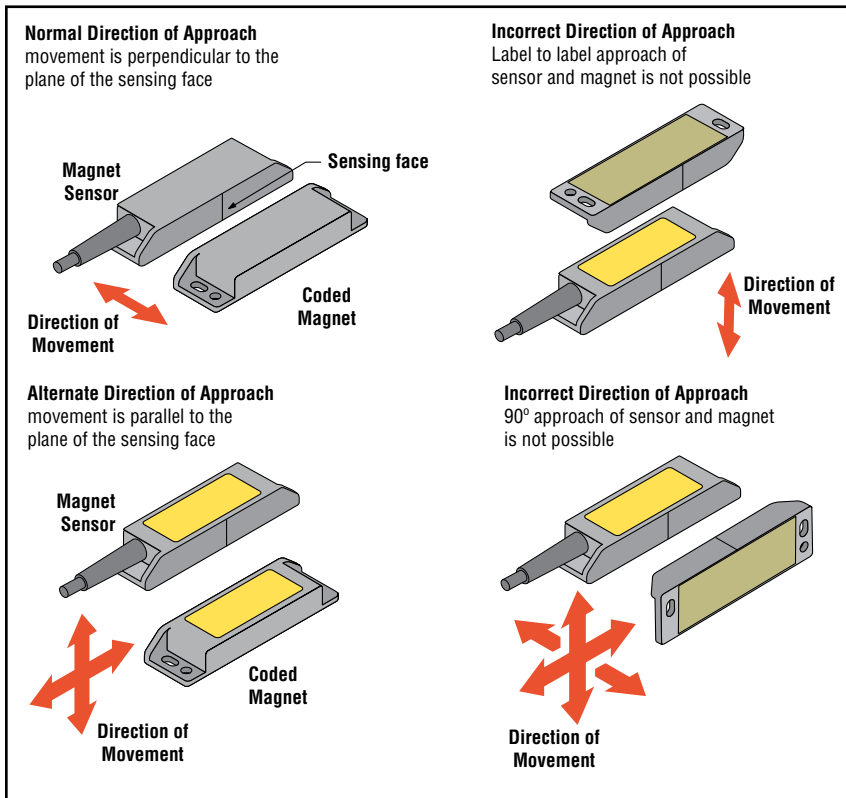

Figure 14a. Direction of Approach for SI-MAG1.. sensor/magnet pairs

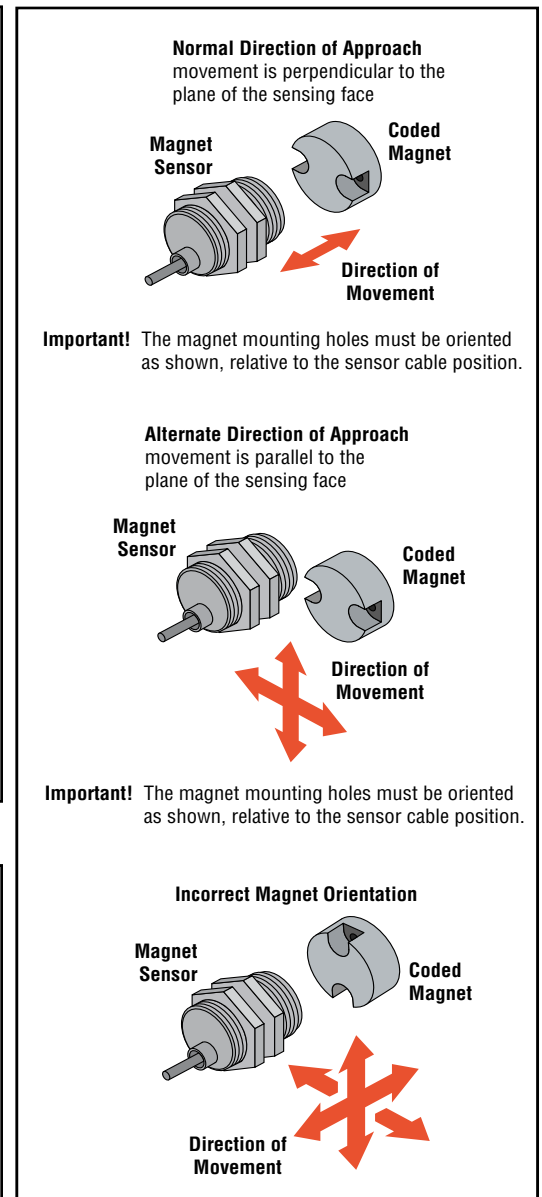

Figure 14c. Direction of Approach for SI-MAG3.. sensor/magnet pairs

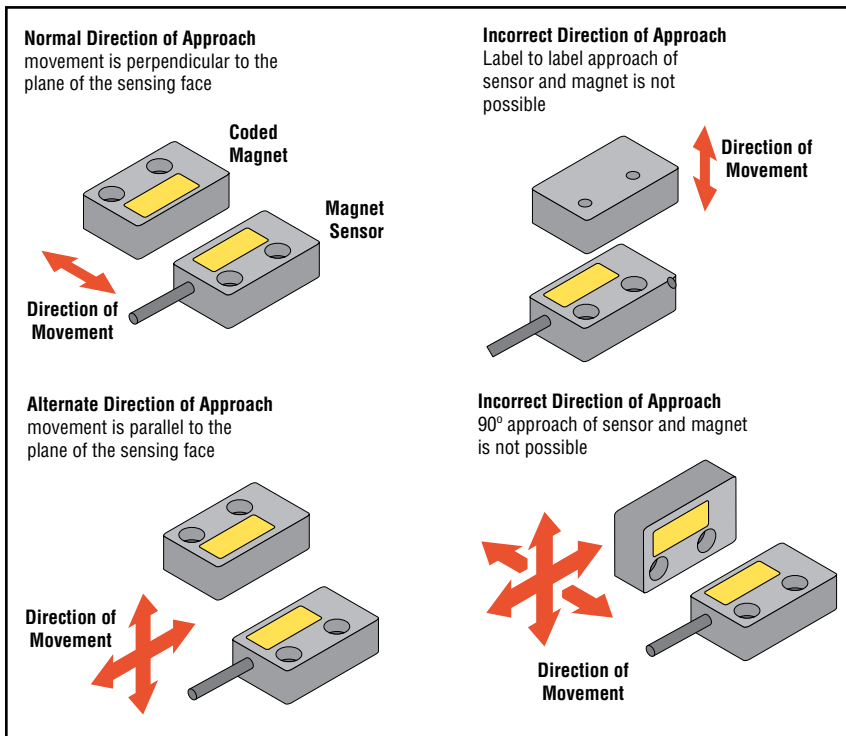

Figure 14b. Direction of Approach for SI-MAG2.. sensor/magnet pairs

NOTE: For all magnet style switches, approach speed must be greater than 0.1 m/s to allow for proper switching. (See page 4.)

Gate Monitoring Safety Module – Model GM-FA-10J

Repairs

Do not attempt any repairs to the GM-FA-10J Safety Module. It contains no field replaceable components. Return the Interface Module to the factory for warranty repair or replacement.

If it ever becomes necessary to return a Safety Module to the factory, contact the Banner Factory Application Engineering Group at the address or numbers listed on the back page. They will attempt to troubleshoot the system from your description of the problem. If they conclude that a component is defective, they will issue an RMA (Return Merchandise Authorization) number for your paperwork and give you the proper shipping address. Pack the Safety Module carefully. Damage which occurs in return shipping is not covered by warranty.



CAUTION . . . Abuse of Module After Failure

If an Internal Fault occurs and the Module will not reset, do not tap, strike, or otherwise attempt to correct the fault by a physical impact to the housing. An internal relay may have failed in such a manner that its replacement is required. If the Module is not immediately replaced or repaired, multiple simultaneous failures may accumulate and the safety function can not be guaranteed.

Troubleshooting

Model GM-FA-10J Gate Monitoring Safety Module provides 5 LED indicators.

LED	Condition	Meaning
Power (green)	ON	Power is connected to terminals A1-A2.
	OFF	No power or low power to terminals A1-A2, or internal power supply failure.
Fault (red)	ON	External fault or configuration fault. The corresponding function LED will flash to indicate the area where the fault has been detected. See page 19 for probable cause.
	Flashing (only)	Internal Fault. See above for repair.
	Flashing (Power LED /flashing)	DIP Switch configuration fault. Check that switch positions are the same for both Banks A and B.
Input 1 (green)	ON	Guard 1 is closed and the inputs of Channel 1 are satisfied.
	OFF	Guard 1 is open or the inputs of Channel 1 are not satisfied.
	Flashing (Fault LED ON)	See page 19 for probable cause.
Input 2 (green)	ON	Guard 2 is closed and the inputs of Channel 2 are satisfied.
	OFF	Guard 2 is open or the inputs of Channel 2 are not satisfied.
	Flashing (Fault LED ON)	See page 19 for probable cause.
Output (green)	ON	Both internal relays K1 and K2 are energized (13/14 and 23/24 are closed).
	OFF	Both internal relays K1 and K2 are de-energized (13/14 and 23/24 are opened).
	Flashing	Reset requested. Cycle the Reset input (button) (open, closed, open) to enter RUN mode.
	Flashing (Fault LED ON)	See page 19 for probable cause.

Gate Monitoring Safety Module – Model GM-FA-10J

Clearing Faults

To clear a fault condition, first correct the problem and then cycle the input channels to the module (open and close the guards). When the Fault LED lights, the corresponding Function LED will flash to indicate the problem. If the Fault LED is flashing, refer to "Repairs," page 18.

NOTE: Input 1: S12/S13

Input 2: S22/S23

LED			Fault, Probable Cause and Procedures
Power	ON	●	INPUT CHANNEL 1 FAULT (S11/S12/S13) a. S13 Open (guard closed) b. S12 Open (guard open) c. S11 Open (guard is open or closed) d. Short between S11 and S12
Fault	ON	●	
Input 1	FLASHING	☀	
Input 2	ON or OFF	●○	
Output	OFF	○	
Power	ON	●	INPUT CHANNEL 2 FAULT (S21/S22/S23) a. S23 Open (guard closed) b. S22 Open (guard open) c. S21 Open (guard is open or closed) d. Short between S21 and S22
Fault	ON	●	
Input 1	ON or OFF	●○	
Input 2	FLASHING	☀	
Output	OFF	○	
Power	ON	●	SHORT BETWEEN INPUT CHANNELS a. Short between S11 and S21
Fault	ON	●	
Input 1	FLASHING	☀	
Input 2	FLASHING	☀	
Output	OFF	○	
Power	ON	●	SIMULTANEITY FAULT a. 2-channel simultaneity > 3 seconds (configured for 2-channel operation) b. Channel simultaneity > 1 second (NO/NC did not switch within 1 second) See page 3 for description of complementary switching and 2-channel operation.
Fault	ON	●	
Input 1	ON or OFF	●○	
Input 2	ON or OFF	●○	
Output	OFF	○	
Power	FLASHING	☀	DIP-SWITCH ERROR a. DIP-switch settings are incorrect; Bank A does not match Bank B See page 10 for DIP-switch configuration.
Fault	FLASHING	☀	
Input 1	OFF	○	
Input 2	OFF	○	
Output	OFF	○	
Power	ON	●	OPEN RESET FAULT a. Y1/Y2 open when configured for Auto Reset See page 10 for Manual/Auto Reset information.
Fault	ON	●	
Input 1	ON	●	
Input 2	ON	●	
Output	FLASHING	☀	
Power	ON	●	INTERNAL FAULT (See page 18 for Repairs) a. Incorrect check sum b. Internal relay failure (e.g., welded contact due to inductive load arcing.) c. Low input power d. Other internal fault
Fault	FLASHING	☀	
Input 1	OFF	○	
Input 2	OFF	○	
Output	OFF	○	