



L-GAGE® Laser Gauging Sensors

Class 2 Visible Laser Displacement Sensor with Both Analog and Discrete (Switched) Outputs

Features



† Patent Pending

- Self-contained Class 2 modulated visible laser gauging sensor needs no separate controller
- Narrow effective beam is excellent for precision gauging applications or for distance, height, or thickness measurement
- Resolution to better than 3 microns for LG5 Series models, and better than 10 microns for LG10 Series models
- Banner's unique scalable analog output† automatically distributes the output signal over the width of the programmed sensing window
- Analog and discrete (switched) outputs with independent window limits
- Analog output slope is either positive or negative, depending upon which window limit is programmed first
- Fast, easy-to-use integrated push-button TEACH-mode programming; no potentiometer adjustments – Remote TEACH function for security and convenience
- Unique feature holds analog output value for 2 seconds upon loss of signal
- Modulated laser beam and narrow optical band-pass filter provide a high level of ambient light immunity, including immunity from high-energy factory lighting
- Alarm output for signal saturation and overload of discrete output
- Output response is programmable for three speeds

Models

Analog Current Output Models (4 to 20 mA)	Analog Voltage Output Models (0 to 10V dc)	Sensing Distance	Focal Point*	Cable**	Supply Voltage	Discrete Output	
LG5A65PI	LG5A65PU	45 to 60 mm (1.8" to 2.4")	70 mm (2.8") Beam size at 53 mm 0.4 mm x 0.6 mm (0.016" x 0.024")	2 m (6.5') (8-wire)	12V to 30V dc	PNP (Sourcing)	
LG5A65PIQ	LG5A65PUQ			Pigtail QD (8-pin Euro)			
LG5A65NI	LG5A65NU			2 m (6.5') (8-wire)		NPN (Sinking)	
LG5A65NIQ	LG5A65NUQ			Pigtail QD (8-pin Euro)			
LG5B65PI	LG5B65PU		53 mm (2.1") Beam size at 53 mm 0.1 mm (0.004")	2 m (6.5') (8-wire)		PNP (Sourcing)	
LG5B65PIQ	LG5B65PUQ			Pigtail QD (8-pin Euro)			
LG5B65NI	LG5B65NU			2 m (6.5') (8-wire)		NPN (Sinking)	
LG5B65NIQ	LG5B65NUQ			Pigtail QD (8-pin Euro)			
LG10A65PI	LG10A65PU	75 to 125 mm (2.9" to 4.9")	180 mm (7.1") Beam size at 125 mm 0.06 mm x 0.8 mm (0.024" x 0.031")	2 m (6.5') (8-wire)		PNP (Sourcing)	
LG10A65PIQ	LG10A65PUQ			Pigtail QD (8-pin Euro)			
LG10A65NI	LG10A65NU			2 m (6.5') (8-wire)			NPN (Sinking)
LG10A65NIQ	LG10A65NUQ			Pigtail QD (8-pin Euro)			

* The Focal Point is the distance, measured from the sensor lens, at which the laser image is smallest (see Figure 4).

** NOTE: 9 m (30') cables are available by adding suffix "W/30" to the model number of any cabled sensor (e.g., LG5A65PI W/30).

See Safety Use Warning on Back Page



L-GAGE® Laser Gauging Sensors

Overview

Banner's Class 2 visible laser displacement sensor brings a sophisticated yet cost-effective solution to precision measurement applications. L-GAGE Series sensors feature all-in-one design and require no separate controller.

The L-Gage Laser Gauging System operates in two modes: TEACH (or programming) and RUN. Near and far sensing window limits are set quickly using simple push-button or remote signal TEACH-mode programming. One sensor can simultaneously provide both analog and discrete (switched) outputs. Sensing window limits for each output may be independently programmed. The analog signal features Banner's unique scalable output (patent pending), which automatically distributes the output signal over the width of the programmed sensing window.

The L-GAGE Laser Gauging Sensor boasts many additional features, including selectable response speed, self-diagnostics with alarm output, comprehensive status indicator system, and unique output "hold" function in case of momentary signal loss in profiling applications.

Optical Triangulation

The design of the L-GAGE Laser Gauging Sensor is based on optical triangulation (see Figure 1). An emitter transmits visible laser light through a lens, toward a target. The laser light beam from the emitter bounces off the target, scattering some of its light through another lens to the sensor's PSD (position-sensitive device) receiver element. The target's distance from the receiver determines the angle the light travels to the receiver element; this angle in turn determines where the received light will fall along the PSD receiver element.

The position of the light on the PSD receiver element is processed through analog and digital electronics and analyzed by the microprocessor, which calculates the appropriate output value. The analog output provides a variable signal that is proportional to the target's position within the user-programmed analog window limits (see page 3). The discrete (switched) output energizes whenever the target is located between the user-programmed discrete window limits. Analog and discrete window limits may be the same, or programmed independently.

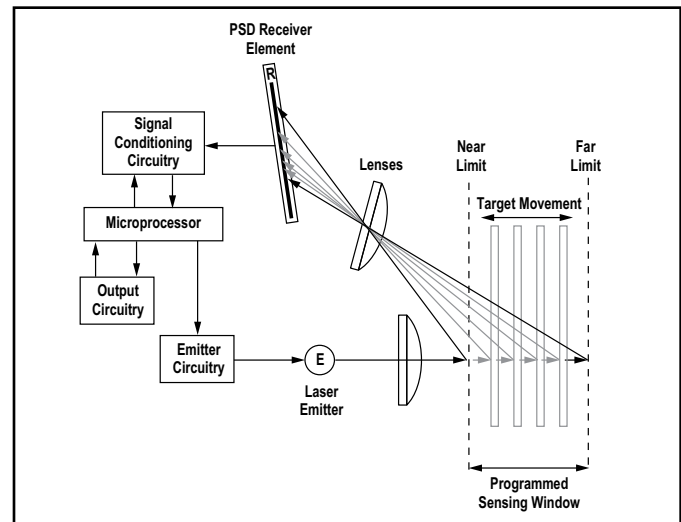

Figure 1. Optical triangulation sensing system overview

Sensor Programming

Program the sensor using either the sensor's keypad or via remote programming. Remote programming is also used to disable the keypad for security, preventing unauthorized or accidental programming adjustment on the production floor.

Remote Programming

For remote programming, connect the sensor's yellow wire to +5 to 30V dc, with a remote programming switch connected between them.

NOTE: The impedance of the remote teach input is 18 kΩ minimum (65 kΩ minimum at 5V).

Programming is accomplished by following the sequence of input pulses, following the button-pushes and "clicks" for programming on the sensor buttons. The duration of each pulse (corresponding to a push button "click"), and the period between multiple pulses, are defined as: 0.04 seconds < T < 0.8 seconds.

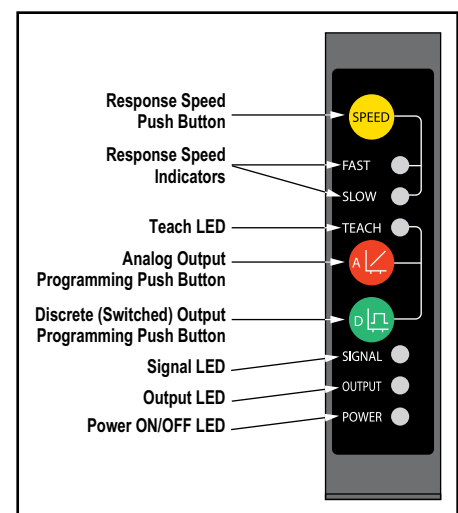

Figure 2. Features

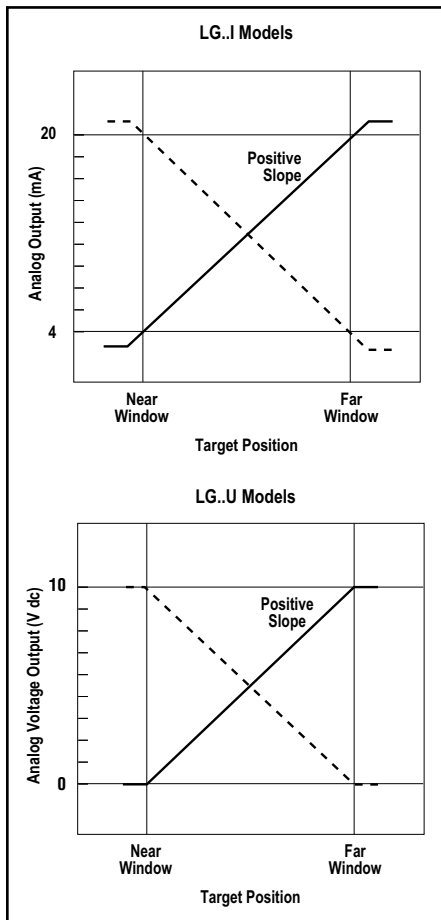

Figure 3. Analog output as a function of target position

Analog Output Slope

The L-GAGE Laser Gauge may be programmed for either a positive or a negative output slope, based on which condition is taught first (see Figure 3). If the near limit is taught first, the slope will be positive; if the far limit is taught first, the slope will be negative. Banner's unique scalable analog output (patent pending) automatically distributes the output signal over the width of the programmed sensing window. Factory analog output is 0 to 10V dc (LG..U models) or 4 to 20 mA (LG..I models).

The L-GAGE also features a 2-second hold upon loss of the analog signal, which is useful for profiling and similar applications. In the event of analog signal loss for longer than 2 seconds, the analog output goes to 0V dc (LG..U models) or 4 mA (LG..I models).

Teaching Analog Limits Using the Auto-Zero Feature (Analog Output)

For some analog applications, a sensing distance set point centered within a sensing window may be required. The TEACH procedure is simple: teaching the same limit twice causes the sensor to program a window centered on the position taught. This window is 10 mm wide (taught position \pm 5 mm).

Teaching Fixed-Field Sensing Mode (Discrete Output)

Teaching the same limit twice creates a sensing window with the far limit at the teach distance and the near limit at the minimum operating range of the sensor (approx. 42 mm for LG5 Series models, and approx. 60 mm for LG10 Series models).

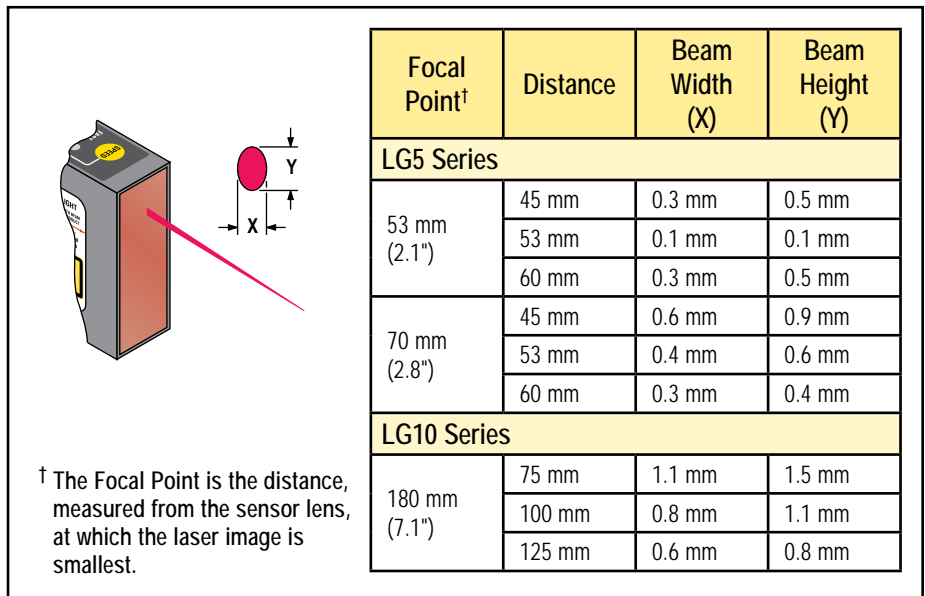











Figure 4. Beam dimensions (typical)

L-GAGE® Laser Gauging Sensors

Teaching Limits for Either Analog or Discrete Output







Either output may be programmed first.

	Push Button 0.04 sec. < "click" < 0.8 sec.		Remote Wire 0.04 sec. < T < 0.8 sec.			
	Procedure	Result	Procedure	Result		
Programming Mode	<ul style="list-style-type: none"> Push and hold push button for Analog or Discrete output > 2 seconds * 	<ul style="list-style-type: none"> TEACH LED turns ON: Red — Analog output Green — Discrete output Sensor is waiting for first limit 	No action required			
Teach First Limit	<ul style="list-style-type: none"> Position the target for the first limit "Click" the same push button 	<ul style="list-style-type: none"> TEACH LED flashes at 2 Hz Sensor learns first limit and waits for second limit 	<ul style="list-style-type: none"> Position the target for the first limit <table border="1"> <tr> <td> Analog Output <ul style="list-style-type: none"> Double-pulse the remote line  </td> <td> Discrete Output <ul style="list-style-type: none"> Single-pulse the remote line  </td> </tr> </table>	Analog Output <ul style="list-style-type: none"> Double-pulse the remote line 	Discrete Output <ul style="list-style-type: none"> Single-pulse the remote line 	<ul style="list-style-type: none"> TEACH LED turns ON: Red — Analog output Green — Discrete output TEACH LED flashes at 2 Hz Sensor learns first limit and waits for second limit
Analog Output <ul style="list-style-type: none"> Double-pulse the remote line 	Discrete Output <ul style="list-style-type: none"> Single-pulse the remote line 					
Teach Second Limit	<ul style="list-style-type: none"> Position the target for the second limit "Click" the same push button 	<ul style="list-style-type: none"> TEACH LED goes OFF Sensor learns second limit and returns automatically to RUN mode 	<ul style="list-style-type: none"> Position the target for the second limit Single-pulse the remote line 	<ul style="list-style-type: none"> TEACH LED goes OFF Sensor learns second limit and returns automatically to RUN mode 		
Program Second Output	Repeat for other output, if a second output is desired.					

* Sensor will return to RUN mode if first TEACH condition is not registered within 120 seconds.

Teaching Limits for Analog and Discrete Outputs Simultaneously

Both Analog and Discrete outputs will have identical limits.

	Push Button 0.04 sec. < "click" < 0.8 sec.		Remote Wire 0.04 sec. < T < 0.8 sec.	
	Procedure	Result	Procedure	Result
Programming Mode	<ul style="list-style-type: none"> Push and hold either push button for > 2 seconds* 	<ul style="list-style-type: none"> TEACH LED turns ON: Yellow Sensor is waiting for first limit 	No action required	
	<ul style="list-style-type: none"> Briefly "click" the other button 			
Teach First Limit	<ul style="list-style-type: none"> Position the target for the first limit "Click" either push button 	<ul style="list-style-type: none"> TEACH LED flashes at 2 Hz, alternating Red and Green Sensor learns first limit and waits for second limit 	<ul style="list-style-type: none"> Position the target for the first limit Triple-pulse the remote line 	<ul style="list-style-type: none"> TEACH LED turns ON: Yellow Sensor learns first limit and waits for second limit TEACH LED flashes at 2 Hz, alternating Red and Green
Teach Second Limit	<ul style="list-style-type: none"> Position the target for the second limit "Click" either push button 	<ul style="list-style-type: none"> TEACH LED goes OFF Sensor learns second limit and returns automatically to RUN mode 	<ul style="list-style-type: none"> Position the target for the second limit Single-pulse the remote line 	<ul style="list-style-type: none"> TEACH LED goes OFF Sensor learns second limit and returns automatically to RUN mode

* Sensor will return to RUN mode if first TEACH condition is not registered within 120 seconds.

Sensor Setup

Response Speed

Use the Speed push button to toggle between the three response speed settings. The combination of indicator lights (Fast and Slow) will tell you which of the three is selected:

Slow	Fast	Analog Output Frequency Response (-3dB)	Discrete Output Response Speed
ON	OFF	4.5 Hz	100 milliseconds
ON	ON	45 Hz	10 milliseconds
OFF	ON	450 Hz	2 milliseconds

L-GAGE® Laser Gauging Sensors

Push Button Lockout

Enables or disables the keypad to prevent accidental or unauthorized adjustment of the programming settings.

	Procedure		Result
	Push Button	Remote Wire 0.04 sec. < T < 0.8 sec.	
Enable/Disable Push Buttons	<ul style="list-style-type: none"> Not available via push button 	<ul style="list-style-type: none"> Four-pulse the remote line 	<ul style="list-style-type: none"> Push buttons are either enabled or disabled, depending on previous condition

Indicators

Signal LED

The Signal LED indicates the strength and condition of the sensor's incoming signal.

Signal LED Status	Indicates
OFF	No signal is received, or the target is beyond the range limitations of the sensor (with some tolerance beyond the recommended minimum and maximum sensing distance)
Flashing @ 2 Hz	Received signal is adequate for processing
Flashing @ 10 Hz	Received signal is in saturation (i.e., signal is too strong); alarm output energizes
ON Solid	Received signal is within the nominal conditions for the sensor

Output LED

The Output LED lights when the discrete output is conducting.

Power ON/OFF LED

The Power ON/OFF LED indicates the operating status of the sensor.

Power ON/OFF LED Status	Indicates
OFF	Power is OFF
Flashing @ 2 Hz	Discrete or alarm output is overloaded
Flashing @ 1 Hz	Power ON, Laser is disabled
ON Solid	Sensor is operating normally (power is ON, Laser enabled)

Power Up/Laser Enable

When powering up the sensor, the following should occur:

- All LEDs turn ON for 1 second
- Allow 1.25 second delay for Laser Enable at power up. (If sensor is already powered up, allow 0.25 second for Laser Enable.)

Installation Notes

Some targets (those with a stepped plane facing the sensor, a boundary line, or rounded targets) pose specific problems for sensing distances. For such applications, see Figure 5 for suggested mounting orientations.

Class 2 Safety Notes

Low-power lasers are by definition incapable of causing eye injury within the duration of the blink, or aversion response of 0.25 seconds. They must also emit only visible wavelengths (400-700 nm). Therefore, an ocular hazard can only exist if an individual overcomes their natural aversion to bright light and stares directly into the laser beam. The product requirements for these lasers are to have a [hazard] label and to have an indicator light to indicate laser emission.

The two operational safety rules are:

- Do not permit a person to stare at the laser from within the beam
- Do not point the laser at a person's eye at close range

Beam Paths:

The beam emitted by a class 2 laser product should be terminated at the end of its useful path. Open laser beam paths should be located above or below eye level where practical.

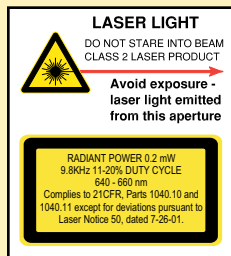

Recommended

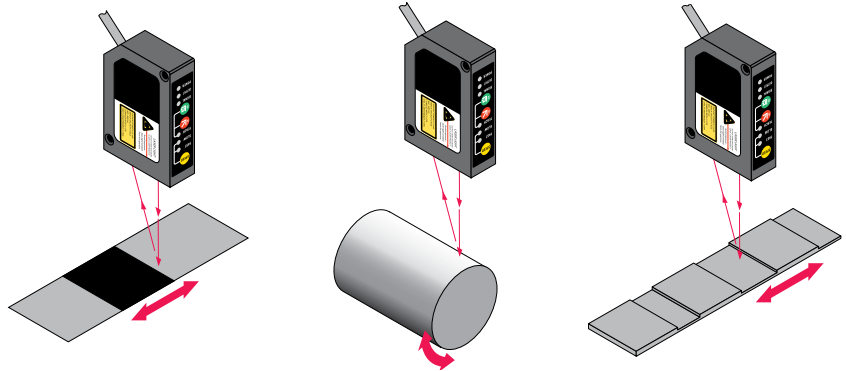

NOT Recommended

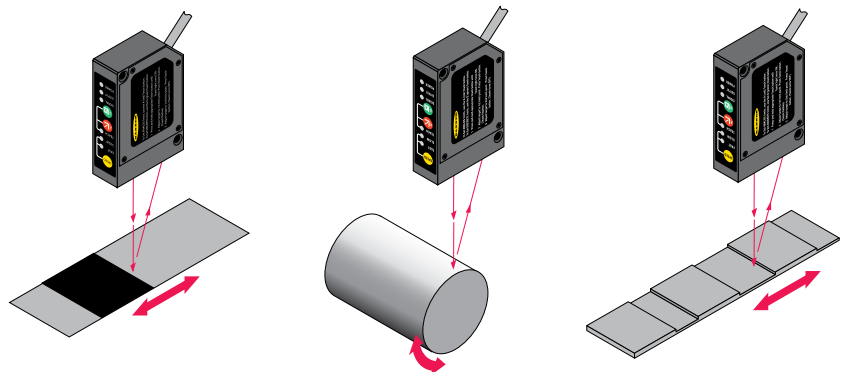

Figure 5. Sensor orientations for typical targets



CAUTION . . . This sensor contains no user-serviceable components.

Do not attempt to repair. Incorrect component values may produce hazardous laser radiation levels.

L-GAGE® Laser Gauging Sensors

Specifications

Sensing Range	LG5: 45 to 60 mm (1.77" to 2.36")	LG10: 75 to 125 mm (2.95" to 4.92")
Supply Voltage	12 to 30V dc (10% maximum ripple); 50 mA max @ 24V dc (exclusive of load)	
Supply Protection Circuitry	Protected against reverse polarity and transient over voltages	
Delay at Power-up	1.25 seconds	
Sensing Beam	650 nm visible red IEC and CDRH Class 2 laser; 0.20 mW radiant output power	
Output Configurations	Discrete (switched) and alarm outputs: SPST solid-state switch; choose NPN (current sinking) or PNP (current sourcing) models Analog current output (LG...I Models): 4 to 20 mA or 20 to 4 mA (current sourcing) Analog voltage output (LG...U Models): 0 to 10V dc or 10 to 0V dc (voltage sourcing)	
Output Ratings	Discrete (switched) and Alarm outputs: 100 mA maximum OFF-state leakage current: less than 5 microamps Output saturation voltage PNP outputs: less than 1.2 volts at 10 mA and less than 1.6 volts at 100 mA NPN outputs: less than 200 millivolts at 10 mA and less than 600 millivolts at 100 mA Analog output (LG...I Models): 1 k Ω max @ 24V dc, max load resistance = [(Vcc - 4.5)/0.02] Analog output (LG...U Models): 2.5 k Ω minimum load impedance	
Output Protection	Discrete and alarm outputs are protected against continuous overload and short circuit	
Output Response Time	Discrete Outputs Fast: 2.0 milliseconds ON and OFF Medium: 10 milliseconds ON and OFF Slow: 100 milliseconds ON and OFF Analog Output (-3dB) Fast: 450 Hz (1 millisecond average with 1 millisecond update rate) Medium: 45 Hz (10 millisecond average with 2 millisecond update rate) Slow: 4.5 Hz (100 millisecond average with 5 millisecond update rate)	
Analog Resolution and Repeatability of Discrete Trip Point* Also see Figures 3 and 6	LG5: Fast: < 40 microns @ 50 mm Medium: < 12 microns @ 50 mm Slow: < 3 microns @ 50 mm	LG10: Fast: < 150 microns @ 100 mm Medium: < 50 microns @ 100 mm Slow: < 10 microns @ 100 mm
Analog Linearity* *Resolution and linearity specified @ 24V dc, 22°C, using a white ceramic test surface (see Application Notes)	LG5: ±60 microns (±0.002") over 45 to 60 mm sensing window ±10 microns (±0.0003") over 49 to 51 mm sensing window	LG10: ±200 microns (±0.008") over 75 to 125 mm sensing window ±20 microns (±0.0008") over 95 to 100 mm sensing window
Minimum Window Size (Analog or Discrete)	LG5: 1.5 mm (0.06")	LG10: 5 mm (0.2")
Hysteresis (Discrete Output)	LG5: < 0.2 mm (0.008")	LG10: < 1.0 mm (0.04")
Color Sensitivity (typical)	LG5: < 75 microns (0.003") for white to dark grey ceramic target	LG10: < 100 microns (0.004") for white to dark grey ceramic target
Temperature Drift	LG5: ±7 microns/°C	LG10: ±25 microns/°C
Remote TEACH and Laser Control Input Impedance	18 k Ω minimum (65 k Ω at 5V dc)	
Laser Control	To enable laser: Connect green wire to +5 to 30V dc To disable laser: Connect green wire to 0 to +2V dc (or open connection) 250 millisecond delay upon enable/disable	
Remote TEACH	To teach: Connect yellow wire to +5 to 30V dc To disable: Connect yellow wire to 0 to +2V dc (or open connection) See Remote Programming on pages 4 and 5.	

Specifications, continued

Adjustments	<p>Response speed: Push button toggles between Slow, Medium, and Fast (see Output Response Time)</p> <p>Window limits (analog or discrete): TEACH-mode programming of near and far window limits (see programming procedure). Limits may also be taught remotely (see pages 4 and 5).</p> <p>Analog output slope: The first limit taught is assigned to the minimum analog output.</p>
Indicators	<p>Green Power ON LED: Indicates when power is ON, overloaded output and laser status.</p> <p>Yellow Output LED: Indicates when discrete load output is conducting.</p> <p>Red Signal LED: Indicates target is within sensing range and the condition of the received light signal.</p> <p>Tri-color Red/Green/Yellow TEACH LED: Indicates sensor is ready for programming each limit (indicates red for analog output, green for discrete, and yellow for simultaneous analog and discrete.)</p> <p>Yellow Fast/Slow LEDs: Combination of 2 lights ON or OFF indicates 1 of 3 response speeds (see page 5).</p> <p>NOTE: See page 6 for more information on indicator behavior.</p>
Construction	<p>Housing: Zinc alloy die-cast, plated and painted finish</p> <p>Cover plate: aluminum with painted finish</p> <p>Lens: acrylic</p>
Environmental rating	IP67, NEMA 6
Connections	2 m (6.5') or 9 m (30') 7-conductor shielded PVC-jacketed attached cable, or 150 mm (6") 8-pin Euro-style pigtail quick-disconnect. Mating QD cables are purchased separately (see page 11).
Operating Conditions	<p>Temperature: -10° to +50° C (+14° to 122° F)</p> <p>Maximum relative humidity: 90% at +50° C, non-condensing</p>
Vibration and Mechanical Shock	<p>Vibration: 60 Hz, 30 minutes, 3 axes</p> <p>Shock: 30G for 11 milliseconds, half sine wave, 3 axes</p>
Application Notes	For comparison, a white ceramic test surface has approximately 91% of the reflectivity of a white Kodak test card with a matte finish. A dark gray ceramic test surface has approximately 11% of the reflectivity of a white Kodak test card with a matte finish. (Allow 15-minute warm-up for maximum linearity.)
Certifications	

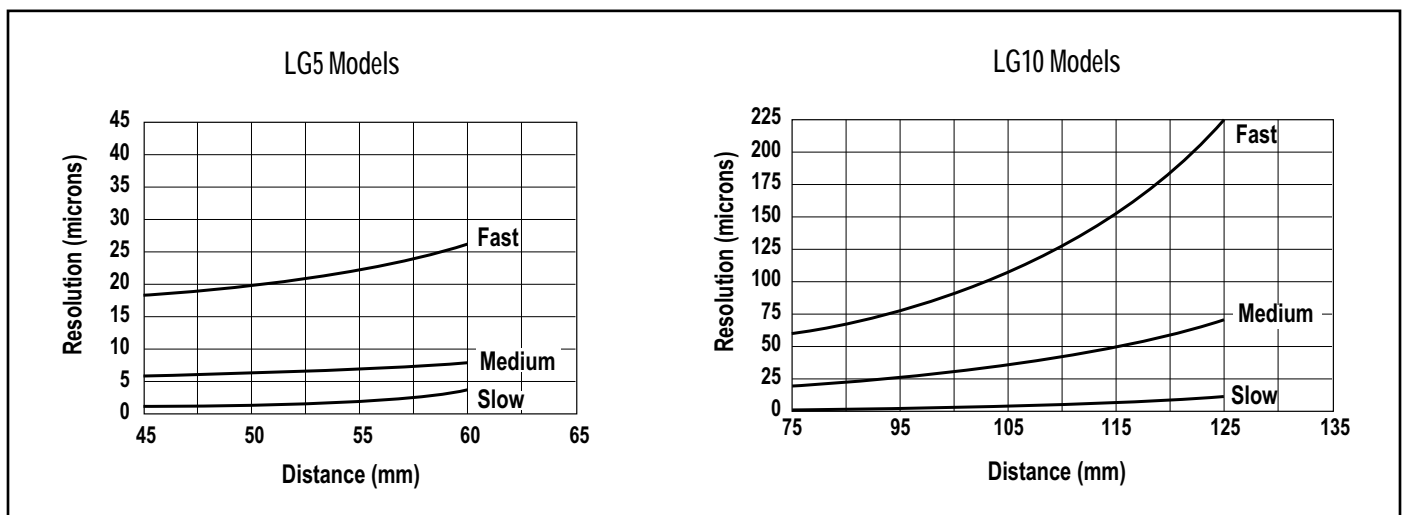
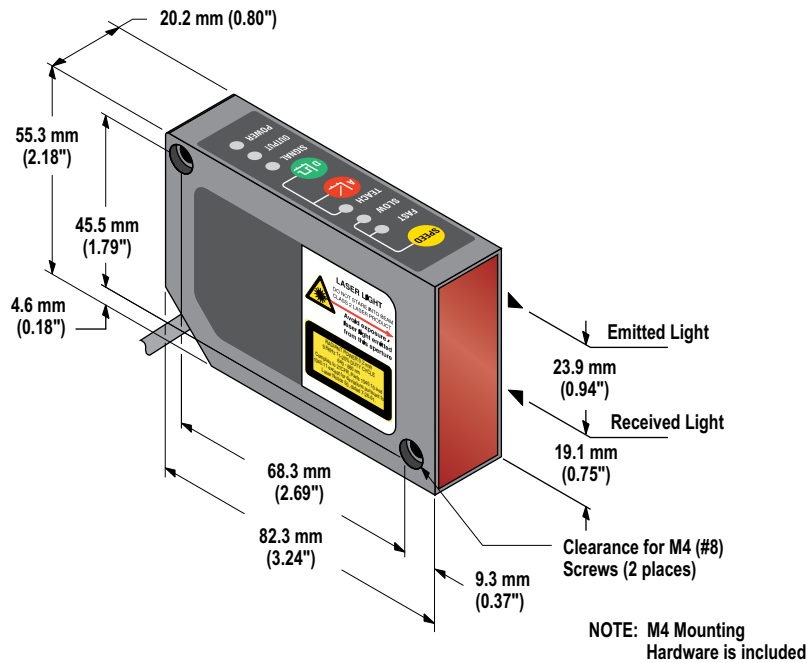

Figure 6. L-GAGE resolution, with respect to speed (typical, using a white ceramic target)

L-GAGE® Laser Gauging Sensors

Dimensions



Hookups

NPN Models

NOTE: Hookups are functionally identical for either integral or QD cable

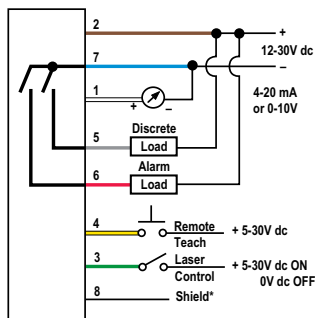

PNP Models

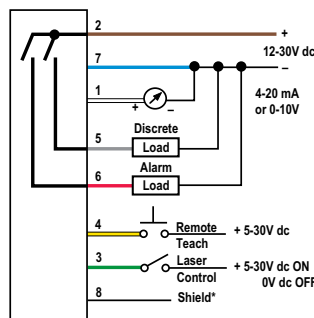

Key 1 = White 2 = Brown 3 = Green
4 = Yellow 5 = Gray 6 = Pink
7 = Blue 8 = Shield

Conversion from Current to Voltage Output (LG..I models only)

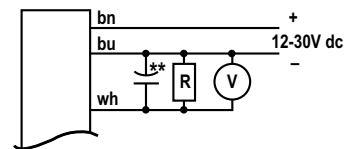

**NOTE: For best results, install a small amount of capacitance (e.g., 0.1 μ F) in parallel with the load resistor

Typical Voltage Response

Value of R	Output Voltage
250	1 to 5V
500	2 to 10V

† 4 to 20 mA (LG..I models) or 0 to 10V dc (LG..U models)

*The bare shield wire is connected internally to the sensor housing and should be connected as follows:

1. If the sensor housing is mounted so that it is in continuity with both the machine frame and earth ground, connect the bare wire (also) to earth ground.
2. If the sensor housing is mounted so that it is insulated from the machine frame, connect the bare wire to -V dc (together with the blue wire).
3. If the sensor is mounted so that it is in continuity with the machine frame, but not with earth ground, do not connect the bare wire (i.e. cut off the bare wire).

L-GAGE® Laser Gauging Sensors

Euro-Style Quick-Disconnect Cables

Cable: PVC jacket, polyurethane connector body, chrome-plated brass coupling nut
 Conductors: 24 AWG high-flex stranded, PVC insulation, gold-plated contacts
 Temperature: -40° to +105° C (-40° to +221° F)
 Voltage Rating: 30V ac/36V dc

Style	Model	Length	Dimensions	Pinout
8-pin Straight	MQDC-830	9 m (30')		<ul style="list-style-type: none"> 1 = White 2 = Brown 3 = Green 4 = Yellow 5 = Gray 6 = Pink 7 = Blue 8 = Shield

Mounting Brackets

SMBLG	<ul style="list-style-type: none"> • L-GAGE sensor mounting bracket • 304 Stainless Steel 		
SMBLGA	<ul style="list-style-type: none"> • L-GAGE adjustable bracket assembly • 304 Stainless Steel 		