

Sonic OMNI-BEAM™

Switched or Analog output

Piezoelectric Ultrasonic Proximity Sensors



- Short-range ultrasonic proximity detection from 4 to 26 inches
- True windowing, with reliable near-limit cutoff; both position and size of the sensing window are quickly and easily adjusted
- Exclusive moving-dot LED indicator for visual display of relative target position within the sensing window
- Relay output models are programmable for either ON/OFF presence detection or HIGH/LOW level control
- Analog output models source 0 to +10V dc, positive or negative slope, between the limits of the sensing window
- Relay output models allow adjustment of sensor response to specific target characteristics to reduce false signals and nuisance signal loss
- Piezoelectric transducer is protected from hostile environments by a KAPTON® polyimide film seal; sensors are fully-gasketed

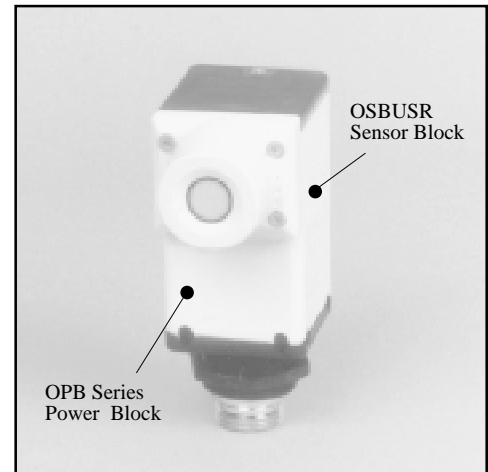

Banner's Sonic OMNI-BEAM™ piezoelectric ultrasonic proximity sensors detect targets within an adjustable sensing "window" (see diagram, below). These sensors feature *true windowing*, with reliable near-limit cutoff. Both the location and size of the window are easily adjusted within the sensor's 4 to 26-inch range. A Sonic OMNI-BEAM sensor consists of a *sensor block module* and a *power block module*. All models use the model OSBUSR sensor block module. A compatible power block is chosen on the basis of operating voltage and output type. Power block modules are available either with a form "C" SPDT electromechanical output relay or with solid-state analog voltage sourcing outputs. Models are listed on page 3.

A ten-element array of LED indicators, built into the top of the OSBUSR sensor block module, visually displays the relative position of a target within the sensing window. This moving-dot target position indicator makes initial setup fast and easy, and provides a continuous visual display of sensor performance. Sensor operating status is fully displayed by separate LED indicators for TARGET PRESENT (anywhere within the 4 to 26-inch sensing range) and LOAD (electromechanical output relay) energized.

Relay output power block modules may be programmed for either of two *control modes*. In the ON/OFF control mode, the output relay is energized whenever a target object is detected within the sensing window. The second control mode, the HIGH/LOW mode, provides the switching logic required for fill-level or web tensioning (loop) control. In the HIGH/LOW mode, the output relay is energized when the target moves beyond the far limit

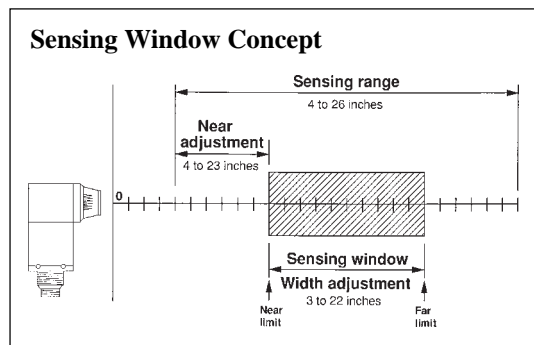

of the sensing window, but does not de-energize until the target reaches the near limit. The relay energizes again when the target passes the far limit. Operating mode selection is done via a switch inside the model OSBUSR sensor head. When a relay-output power block is used, the 10-element LED display indicates the relative position of a target within the sensing window.

Analog voltage sourcing power block modules have two separate voltage sourcing solid-state outputs: 0 to +10V dc and +10 to 0V dc. Maximum load current is 10 mA per output. Outputs of dc-operated models are useable simultaneously (see specs). Output voltage is proportional to the distance from the sensor face to a target object detected within the sensing window. This relationship between target distance and analog voltage output may be either positive or negative, depending upon which of the power block outputs is used. When using the "negatively sloped" output, power block output is +10V dc at the near window limit and decreases to 0V dc at the far limit. The "positively sloped" output increases from 0V dc at the near limit to +10V dc at the far window limit. When an analog power block is used, the 10-element LED display indicates the relative position of a target object within the sensing window and the approximate power block output voltage.

When a relay output power block is used, sensor response is programmable by selecting the number of consecutive sensing cycles that are required to verify the presence (or absence) of a target before the sensor's output is allowed to change state. The sensor may be programmed to "wait" 1, 3, 10, or 30 consecutive sensing cycles. This useful feature may be used to "smooth" sensor response by preventing false response to nuisance signals or to intermittent signal loss. The sensor can also be adjusted for faster response (shorter "wait") when required. Sensor response programming is done via easily-accessible DIP switches located inside the base of the sensor head. The response time programming feature is not operative when an analog power block is used.



WARNING These ultrasonic presence sensors do NOT include the self-checking redundant circuitry necessary to allow their use in personnel safety applications. A sensor failure or malfunction can result in *either* an energized or a de-energized sensor output condition.

Never use these products as sensing devices for personnel protection. Their use as safety devices may create an unsafe condition which could lead to serious injury or death.

Only MACHINE-GUARD and PERIMETER-GUARD Systems, and other systems so designated, are designed to meet OSHA and ANSI machine safety standards for point-of-operation guarding devices. No other Banner sensors or controls are designed to meet these standards, and they must NOT be used as sensing devices for personnel protection.

Sonic OMNI-BEAM

The piezoelectric transducer must remain clean and dry for reliable sensing. A KAPTON® film seal protects the transducer from splash and vapor of water and most chemicals, solvents, lubricants, and fuels. Sensor block and power block housings are molded from tough, corrosion-proof VALOX® thermoplastic polyester. Indicator LEDs are viewed through a gasketed, transparent Lexan® top cover. Power block modules are totally epoxy-encapsulated for maximum reliability. When assembled, all components are fully gasketed.

Power blocks are available either with 6 feet of PVC-covered cable attached or with an integral "QD" (Quick Disconnect) connector. Mating industrial-duty 12-foot *minifast*™ quick-disconnect cables are sold separately. A stainless steel mounting bracket (model SMB30MM) is also available (below).

The model OSBUSR sensor block and the various power block modules must be purchased individually. See the next page to select a power block module appropriate to your needs.

Dimensions

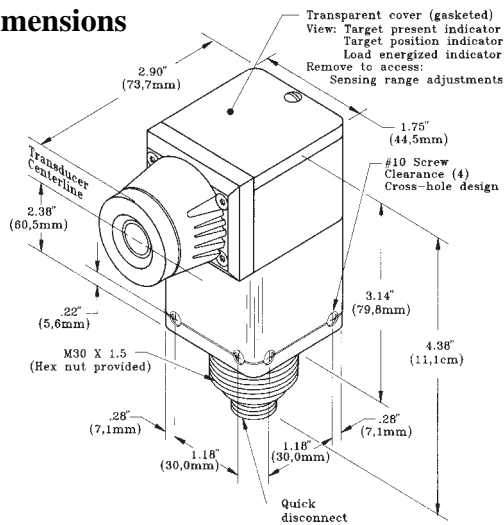

The model OSBUSR sensor head module and the power block module are sold separately.

Model SMB30MM Mounting Bracket

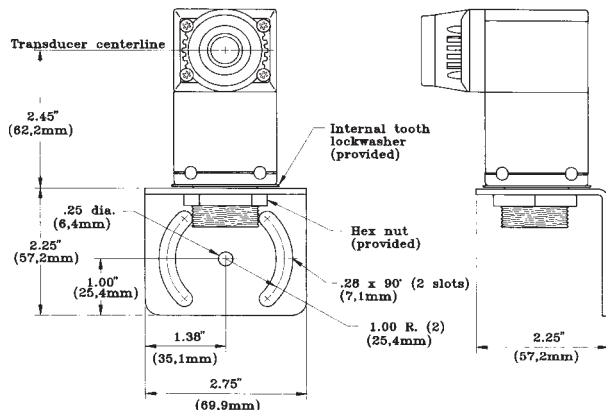

Accessory mounting bracket model SMB30MM has curved mounting slots for versatility in sensor mounting and orientation. OMNI-BEAM™ family sensors mount to the bracket by their threaded base, using a jam nut and lockwasher (both supplied). The curved mounting slots have clearance for 1/4-inch screws. Bracket material is 11-gauge stainless steel.

Specifications

SUPPLY VOLTAGE:

Relay output power blocks

+18 to 30V dc
105 to 130V ac (50/60Hz)
210 to 250V ac (50/60Hz)

Analog output power blocks

+15 to 30V dc
105 to 130V ac (50/60Hz)
210 to 250V ac (50/60Hz)

SENSING RANGE: 4 to 26 inches (10 to 66cm).

WINDOW SIZE: 3 to 22 inches (8 to 56cm) in depth, adjustable.

LIMIT ADJUSTMENTS (all models): near and far window limits are independently adjustable using 15-turn clutched potentiometers (with slotted brass elements), located beneath a gasketed cover on top of the sensor. A small, flat-bladed screwdriver is required for adjustment. NOTE: Always set near limit first (by adjusting the NEAR control); the far limit is set by adjusting the WIDTH control.

OPERATING MODES:

With relay output power block

1) **ON/OFF mode.** Output relay energizes when target is within the sensing window.

2) **HIGH/LOW mode.** Output relay energizes when target moves beyond the far limit, and de-energizes when target moves inside the near limit.

With analog output power block

Power block analog voltage output is proportional to the position of a target object detected within the sensing window. The relationship between the 0 to 10V dc analog voltage output and target distance is selectable, and may be either positive or negative.

STATUS INDICATORS:

With relay output power block

LED indicators for TARGET PRESENT and LOAD (relay energized). Ten-element moving-dot display indicates relative position of the target within the sensing window.

With analog output power block

LED indicators for TARGET PRESENT. Ten-element moving-dot display indicates relative position of the target within the sensing window and approximate analog voltage output.

RESPONSE TIME:

With relay output power block

programmable for 1, 3, 10 or 30 consecutive sensing cycles for target presence/absence verification (25ms/cycle).

With analog output power block, 25 milliseconds

OUTPUT:

Relay output power blocks

One form "C" SPDT relay, silver nickel alloy contacts.

Maximum voltage: 250V ac or 30V dc (resistive load)

Maximum current: 7 amps (resistive load)

Minimum load: 5V dc at 10 milliamps

Mechanical life: 50,000,000 operations

Electrical life: 100,000 operations (at full-rated resistive load)

Analog output power blocks

Two solid-state outputs: 0 to +10V dc sourcing and +10 to 0V dc sourcing. Outputs may be used simultaneously. **Maximum load for dc powered models is 10mA each output. Outputs of ac powered models may also be used simultaneously, but total load may not exceed 10mA.** Protected against short-circuit and overload.

OUTPUT CONNECTOR: 6-foot attached PVC-covered cable, or integral threaded standard quick-disconnect connector. Twelve-foot long mating quick-disconnect cables are sold separately (next page).

CONSTRUCTION: Housing: molded VALOX® thermoplastic polyester. **Top view window:** transparent Lexan® polycarbonate.

Sensor seal: KAPTON® polyimide type HN film. **Hardware:** stainless steel. When assembled, all components are fully gasketed and rated NEMA 4.

OPERATING TEMP: 0 to 50°C (+32 to 122°F).

HUMIDITY: 90% maximum relative humidity (non-condensing).

KAPTON is a registered trademark of Dupont Co.

VALOX and Lexan are registered trademarks of General Electric Co.

Sonic OMNI-BEAM

Selecting a Power Block Module

A power block module performs the dual functions of providing the proper operating voltage for the sensor block and of interfacing the sensor block to the circuit to be controlled. See *Specifications* for information on power block output load capacity. Below is a list of power block modules that may be used with the Sonic OMNI-BEAM OSBUSR sensor block module. *Sensor block (OSBUSR) and power block must be ordered separately.*

Model	Output(s)	Required supply voltage	Cable Type
OPBA5	form "C" SPDT electromechanical relay	105 to 130V ac (50/60 Hz)	6-ft. 5-conductor PVC-covered cable
OPBA5QD	form "C" SPDT electromechanical relay	105 to 130V ac (50/60 Hz)	MBCC-512 cable required (see below)
OPBB5	form "C" SPDT electromechanical relay	210 to 250V ac (50/60 Hz)	6-ft. 5-conductor PVC-covered cable
OPBB5QD	form "C" SPDT electromechanical relay	210 to 250V ac (50/60 Hz)	MBCC-512 cable required (see below)
OPBT5	form "C" SPDT electromechanical relay	18-30V dc, 100mA max.	6-ft. 5-conductor PVC-covered cable
OPBT5QD	form "C" SPDT electromechanical relay	18-30V dc, 100mA max.	MBCC-512 cable required (see below)
OPBA3	analog solid-state voltage sourcing (2)	105 to 130V ac (50/60 Hz)	6-ft. 5-conductor PVC-covered cable
OPBA3QD	analog solid-state voltage sourcing (2)	105 to 130V ac (50/60 Hz)	MBCC-512 cable required (see below)
OPBB3	analog solid-state voltage sourcing (2)	210 to 250V ac (50/60 Hz)	6-ft. 5-conductor PVC-covered cable
OPBB3QD	analog solid-state voltage sourcing (2)	210 to 250V ac (50/60 Hz)	MBCC-512 cable required (see below)
OPBT3	analog solid-state voltage sourcing (2)	15 to 30V dc, 100mA max.	6-ft. 4-conductor PVC-covered cable
OPBT3QD	analog solid-state voltage sourcing (2)	15 to 30V dc, 100mA max.	MBCC-412 cable required (see below)

Hookup Information: OPBA5, OPBA5QD, OPBB5, OPBB5QD, OPBT5, OPBT5QD Electromechanical Relay Output Power Blocks

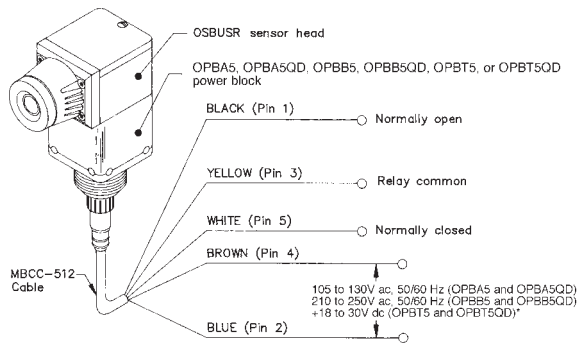

*Models OPBT5 and OPBT5QD: BROWN wire = +V dc; BLUE = dc common.

Functional Diagram: Sensors with Electromechanical Relay Output

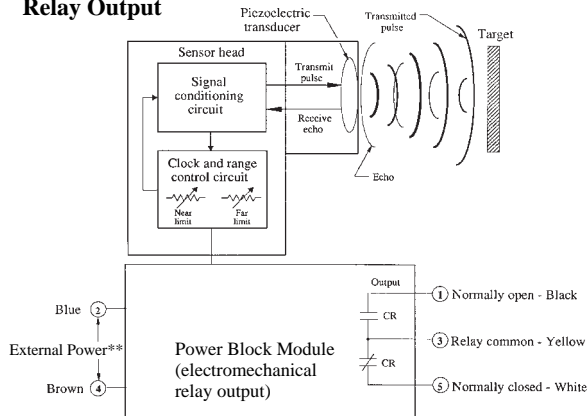

**External Power: 105-130V ac, 210-250V ac, or +18 to 30V dc, depending upon power block model (table, above). Models OPBT5, OPBT5QD: BROWN wire = +V dc; BLUE = dc common.

Hookup Information: OPBA3, OPBA3QD, OPBB3, OPBB3QD Analog Output Power Blocks

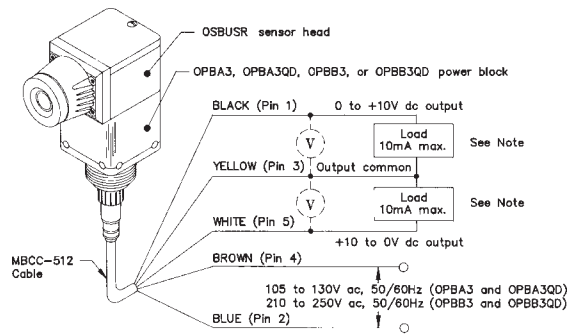

NOTE: If both outputs are used simultaneously, the total current demand of both loads must not exceed 10mA.

Hookup Information: OPBT3 and OPBT3QD Analog Output Power Blocks

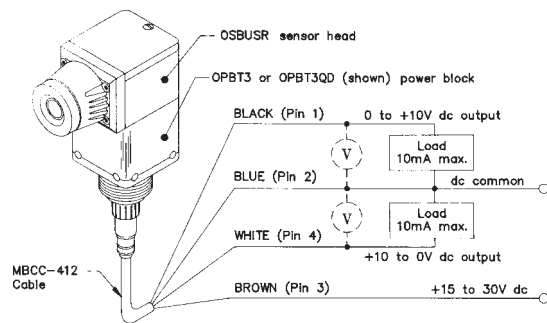

NOTE: If both outputs are used simultaneously, the maximum load per output may not exceed 10 mA.

minifast™ QD Cables for QD model power blocks (purchase cables separately; see table above)

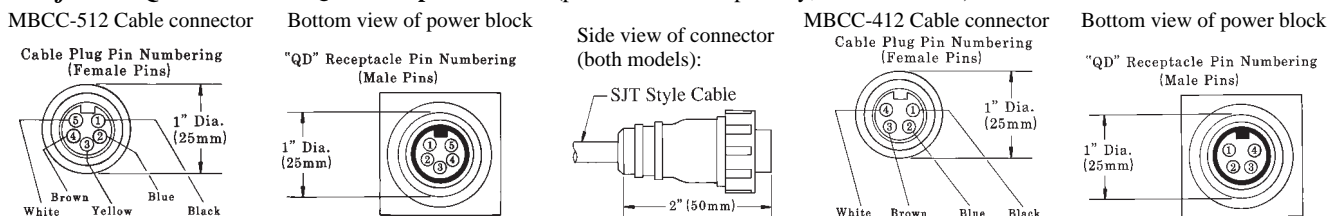

Adjustment Information

Power Blocks with ELECTROMECHANICAL RELAY Output

Two operating parameters are programmable via a set of four DIP switches located at the base of the sensor head (see photo, right). The four captive screws that fasten the sensor head to the power block are loosened to gain access to the switches. The switches may be flipped up ("on") or down ("off") using the tip of a ballpoint pen or a small screwdriver. See drawing below.

Switches #1, #2, and #3 select the number of consecutive sensing cycles required for target presence or absence verification. This feature enables the sensor to be adjusted for smooth response in any sensing application:

- All switches "off" = 1 cycle (25ms response)
- Switch #1 "on" = 3 cycles
- Switch #2 "on" = 10 cycles
- Switch #3 "on" = 30 cycles
- More than 1 switch "on" = (cycle count is additive)
- Factory setting is switch #1 "on" = 3 cycles

Switch #4 selects the output control mode. Switch #4 "on" = ON/OFF mode (factory setting). Switch #4 "off" = HIGH/LOW mode.

Sensing Window Adjustment

The LOAD indicator LED is used to locate and "size" the sensing window. The NEAR limit and window WIDTH adjustments are 15-turn potentiometers, clutched at both ends of travel. They are adjusted using a small, flat-blade screwdriver. Clockwise rotation of the NEAR limit adjustment moves the near window limit farther away from the sensor, and counterclockwise rotation moves the near window limit closer to the sensor. Clockwise rotation of the window WIDTH adjustment increases the size of the sensing window; counterclockwise rotation decreases the size of the sensing window. The window adjustment procedure is slightly different for each control mode. NOTE: the TARGET PRESENT indicator LED lights whenever a target is sensed anywhere within the 4 to 26-inch sensing range, regardless of the window adjustments.

The factory settings are:

- NEAR limit = control fully counterclockwise
- window WIDTH = 26 inches

NOTE: With the NEAR limit control fully counterclockwise, the sensing window width is referenced to the sensor face (zero inches). With these limit settings, and with switch #4 at its factory setting for ON/OFF operation, the unit will function as a presence detector over its full sensing range (i.e. the output relay will be energized whenever a target is sensed within the sensor's 4 to 26-inch range). The window adjustment procedures discussed below begin with these factory settings.

Window adjustment for the ON/OFF output control mode (programming switch #4 "on"):

- 1) Position the target material at the desired near limit of the sensing window. Rotate the NEAR limit control clockwise to find the point where the load indicator just turns "off".
- 2) Move the target material to the desired far limit of the sensing window and rotate the window WIDTH control counterclockwise to find the point at which the LOAD indicator just turns "off".
- 3) Reposition the target at the near window limit and readjust the NEAR limit control (if necessary) to re-establish the switching point.
- 4) Check the far window limit if any adjustments were made in step #3. Readjust the window WIDTH control, if necessary.
- 5) The moving-dot LED display will confirm the window dimensions by indicating the relative position of the target within the established window, in 10% increments.

Window adjustment for the HIGH/LOW output control mode (programming switch #4 "off"):

- 1) Remove all objects within the sensing range. The TARGET PRESENT indicator should be "off"; the LOAD indicator should be "on".
- 2) Position the target material at the desired near limit of the sensing window. Rotate the NEAR limit control clockwise to find the point at which the LOAD indicator just turns "off".
- 3) While keeping the target within the sensing field (TARGET PRESENT indicator always "on"), carefully move the target to the desired far window limit. Then rotate the window WIDTH control counterclockwise to find the point at which the LOAD indicator just turns "on".
- 4) Reposition the target at the near limit and readjust the NEAR limit control, if necessary, to re-establish the switching point.
- 5) Check the far limit if any adjustments were made in step #3. Readjust the window WIDTH control, if necessary.

APPLICATION NOTES (see also page 6)

- 1) The sensing pattern is narrow. Flat targets must be parallel to the face of the sensor to within +/-3 degrees (depending upon target reflectivity).
- 2) The transducer is protected by a KAPTON® film. However, the transducer must be kept clean and dry during operation.
- 3) Sensing at less than 4 inches from the face of the transducer is not reliable.

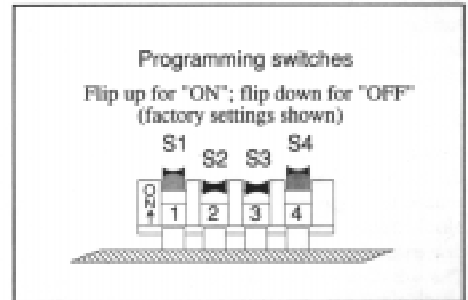
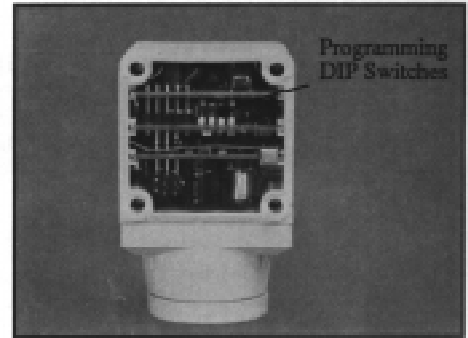

Top of sensor (cover removed), showing LED array, LOAD and TARGET PRESENT indicators, and sensing window adjustment controls.

Adjustment Information

Power Blocks with ANALOG Output

The programming DIP switches inside the OSBUSR sensor block have no effect when using analog power blocks. The only adjustments are to the NEAR and WIDTH potentiometers. Note: The status of the LOAD indicator LED should be disregarded when a sensor with an analog power block is being adjusted.

Sensing Window Adjustment

A dc voltmeter is used to locate and to "size" the sensing window. The NEAR and FAR limit adjustments on top of the sensor head (see photo on page 4) are 15-turn potentiometers, clutched at both ends of travel. They are adjusted using a small, flat-blade screwdriver. *Clockwise* rotation of either limit adjustment moves that window limit *farther* away from the sensor. *Counterclockwise* rotation moves that limit *closer* to the sensor.

Refer to the hookup drawings for ANALOG output power blocks on page 3. If the positively-sloped power block output (black wire) is used, the analog value of the output increases from 0 to +10 volts dc as the sensor-to-target distance increases. If the negatively-sloped power block output (white wire) is used, the analog value of the output decreases from +10 to 0 volts as the sensor-to-target distance increases. The window width may be set at from 3 inches to 22 inches. This sensing window may be placed anywhere within the 4 to 26 inch sensing range of the OSBUSR sensor block. NOTE: The NEAR limit may be referenced as close as zero inches (i.e. zero inches equals zero volts or +10 volts output); however, sensing is not reliable within the first 4 inches from the transducer face.

The factory settings are:

Near limit (NEAR control) = 0 inches

Far limit (WIDTH control) = 26 inches

With these settings, the voltage at the minimum sensing range (4 inches) will be approximately 1.6V dc (positive slope selected) or 9.4V dc (negative slope selected).

Window adjustment procedure:

1) Remove the transparent plastic top cover of the sensor head for access to the NEAR and WIDTH adjustments. Connect a dc voltmeter across either the black and yellow wires or the white and yellow wires of the cable (depending upon the output to be used) with or without the load connected. Connect the brown and blue power supply wires from the cable to a suitable power source and apply power.

2) Position the target material at the desired near limit of the sensing window. Rotate the NEAR limit control to the point where the output voltage just equals 0.0 V dc (*black* and *yellow* output wires in use, positive slope) or 10.0V dc (*white* and *yellow* output wires used, negative slope). For positive slope adjustment, rotate the control clockwise to decrease the voltage; rotate counterclockwise to increase the voltage. For negative slope adjustment, rotate counterclockwise to decrease and clockwise to increase.

3) Move the target material to the desired far limit of the sensing window and rotate the WIDTH control to find the point at which the output voltage just equals 10.0 V dc (positive slope) or 0.0V dc (negative slope). For positive slope adjustment, rotate the control clockwise to decrease the voltage; rotate counterclockwise to increase the voltage. For negative slope adjustment, rotate counterclockwise to decrease and clockwise to increase.

4) Reposition the target material at the near limit and readjust the NEAR limit control, if necessary, to re-establish the correct dc output (repeat step #2).

5) If any adjustment was necessary in step #4, recheck the far limit and readjust the WIDTH control (repeat step #3), if necessary.

Sonic OMNI-BEAM Analog Outputs

The graphs below show the relationship between the target object position within the sensing window, the number of LED array indicators "on", and the analog dc voltage output for sonic OMNI-BEAM sensor block module OSBUSR used with one of the following analog power block modules: OPBA3, OPBA3QD; OPBB3, OPBB3QD; OPBT3, OPBT3QD. Graphs for both positive slope and negative slope output are shown.

Positive slope: output voltage increases with target distance

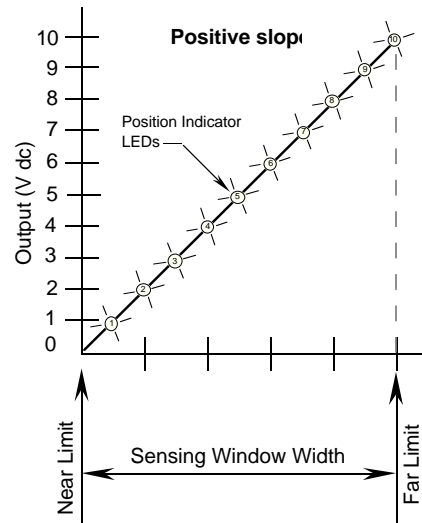

Negative slope: output voltage decreases with target distance

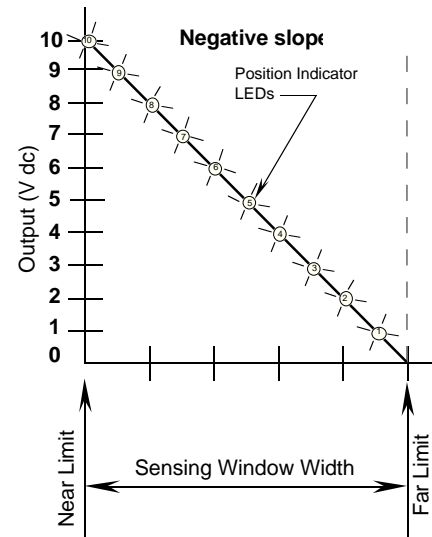

6) The moving-dot LED display will confirm the window dimensions by indicating the *relative position of the target within the established window*, in 10% increments.

BASIC THEORY OF ULTRASONIC SENSING

Ultrasonics are sound waves of frequencies above the range of human hearing. In sonic OMNI-BEAM™ sensors, ultrasonic waves are produced by a vibrating object called a *piezoelectric transducer*. This transducer is part of an electrical circuit, and "rings" when an ac voltage "spike" is applied to it. This ringing compresses and expands the air molecules in front of the sensor, sending "waves" of ultrasonic sound outward from the transducer's face. The transducer is not *constantly* transmitting ultrasonic sound, but is switched "on" and "off" at a regular rate. During the "off" times, the transducer acts as a receiver and *listens* for ultrasonic reflections from objects in its path.

A basic knowledge of how ultrasonic waves behave in air, which is presented below, can be of help in using ultrasonic sensors successfully.

Behavior of Ultrasonic Waves

(1) The intensity of ultrasonic sound decreases at a rate equal to the square of the distance from the sound source.

For example, if the intensity of ultrasonic sound at a distance of 1' in front of the sensor is designated as "1", then the intensity at 3 times that distance is $(1/3)^2$, or 1/9th. If these waves are reflected back to the sensor, the intensity of the waves decreases *again* by the square of the distance. *The stronger the generated ultrasonic waves, the stronger will be the returned waves. And, the more efficient the object is as a reflector of ultrasonic waves, the stronger will be the returned waves.*

(2) Ultrasonic waves are affected by the size, density, orientation, shape, surface, and location of the object being sensed.

a) Size of the object. At a given distance in front of the sensor, a large object reflects more ultrasonic energy than does a smaller, otherwise identical object at the same position, and so is more easily sensed. The recommended object size for the sonic OMNI-BEAM sensor is 1 square inch of reflective surface area *presented to the sensor* for each inch of sensing distance. EXAMPLE: at a sensing distance of 25 inches, the object should be 25 square inches (5 inches x 5 inches) in size. This is an "average figure", and is influenced by other characteristics of the object being sensed.

b) Density of the object. *Density is the mass of an object per unit of volume. The more dense the object being sensed, the stronger is the sound reflection, and the more reliably the object can be sensed.* For example, a wall covered with hardboard paneling reflects sound more efficiently than does a wall of foam insulation panels. The hardboard paneling is denser than the foam. Note that water and other liquids (although certainly not solid) are nonetheless denser (and better reflectors of ultrasound) than are materials like foam.

Basic Guidelines for Object Density and Surface:

- 1) The greater the density of the object, the stronger the reflection.
- 2) The smoother the surface of the object, the stronger the reflection.

c) Object orientation, shape, and surface characteristics. Ultrasonic waves follow the same laws of reflection as do light waves. *The angle of incidence equals the angle of reflection.* This means that ultrasonic waves are reflected from a smooth, flat surface at an equal and opposite angle to the incoming angle. A perfectly flat object that is exactly perpendicular to the direction of travel (the "axis") of the ultrasonic waves will reflect the waves back along the same path.

As the object's reflecting surface is tilted away from the axis of the waves, however, less and less of the ultrasonic signal is reflected back to the sensor. Eventually the point is reached beyond which the object can no longer be sensed. *When attempting to sense an object with a flat, smooth surface, the angle of the reflecting surface to the sensing axis should never be more than 3° off of perpendicular.*

Irregularly shaped objects and aggregate matter (coal, ore, sand, etc.) have many reflecting faces of many different angles. Although these faces scatter much of the ultrasonic energy away from the sensor, enough sound energy may be reflected back to the sensor for reliable sensing. In fact, due to the large number of reflecting surfaces, the "perpendicularity requirement" described above may not be nearly as critical for these materials. Sensor angles of up to several degrees away

from perpendicular often produce adequate reflections. Some materials may actually produce just as good reflections when sensed "at an angle" as when sensed "straight on". This phenomenon allows a degree of freedom in choosing a sensor mounting location for some applications. Some trial-and-error experimentation may be required.

d) Location of the object within the sensor's response pattern. The ultrasonic signal radiated from the sonic OMNI-BEAM is strongest along the "sensing axis" and drops off with increasing angle away from the axis. *Objects are most reliably sensed when they are as close as possible to the sensing axis.*

e) Location of sidewalls with respect to the beam pattern. *Sidewalls* located close to the sensing axis may sometimes cause unwanted signals to be reflected back to the sensor. Unwanted reflections may also occur from deposits of material adhering to the sidewalls of hoppers, bins, etc. If possible, align the sensor so that its beam will not encounter sidewalls, and try to keep sidewalls free of buildup.

(3) Extreme environmental conditions may affect ultrasonic sensing. Temperature, thermal air currents, wind, humidity, and atmospheric pressure all exert some effect on ultrasonic waves.

a) The speed of sound increases and decreases slightly with increases and decreases in ambient temperature. A large temperature increase will "move" the object slightly *towards* the sensor. A large decrease will "move" the object slightly *away* from the sensor.

The amount of shift is 3.5% of the sensing distance and window limits for every 20°C of temperature change. **It is a good idea to set the sensing window limits when the ambient temperature is midway in the expected environmental operating temperature range of the sensor. Whenever possible, adjust the sensing window so that the object(s) to be sensed will pass through the midpoint of the window.**

Fluctuations in the speed of sound and signal strength can occur when hot objects are sensed or when the air temperature between the sensor and the object fluctuates. A small fan blowing *along the sensing axis* helps to thermally stabilize the sensing path.

b) Care should be taken to shield ultrasonic sensors from sustained, loud sounds such as factory whistles and similar sources. Sound sources produce *harmonics* (sounds at frequencies above the fundamental frequency of the source). Harmonics may fall in the ultrasonic range and "confuse" ultrasonic sensors. **High pressure air blasts** are especially good producers of harmonics in the ultrasonic range. Since sound waves travel in a straight line from the harmonic source to the sensor, **the solution is simple:** a wall or baffle placed between the sensor and the harmonic source is nearly always sufficient. This tactic can also help prevent possible interference between ultrasonic sensors.

c) Humidity: extreme changes in humidity influence ultrasonic sensing by a maximum of 2% of the sensing distance or window limits. While the *speed* of sound increases with increasing humidity, heavy fog increases sound absorption and reduces sensing *range*.

d) Atmospheric pressure: a 5% increase in atmospheric pressure increases the speed of sound by 0.6%. A 5% decrease in pressure slows the speed of sound by 0.6%.

e) Condensation or other contamination on the transducer face can seriously impede sensor performance, and should be avoided. Condensation or particulates on the transducer dampen its movement. Most contamination can be prevented by mounting the sensor in the driest, cleanest location possible that still allows reliable sensing performance in a given application. **Never mount the sensor "face up" in areas where contamination might be a problem.**

WARRANTY: Banner Engineering Corporation warrants its products to be free from defects for one year. Banner Engineering Corporation will repair or replace, free of charge, any product of its manufacture found to be defective at the time it is returned to the factory during the warranty period. This warranty does not cover damage or liability for the improper application of Banner products. This warranty is in lieu of any other warranty either expressed or implied.