

# OPTO-TOUCH™ LTB Series *Alternate Action Optical Touch Buttons*



Banner LTB Series Optical Touch Buttons are **touch-activated photoelectric switches designed to replace capacitive touch switches and mechanical push buttons**. The OPTO-TOUCH's SPDT electromechanical relay output changes state, alternating between "on" and "off", whenever a finger, introduced into the "touch area" (yoke) of the switch, interrupts the LTB's infrared sensing beam.

Banner LTBs are ergonomically designed to eliminate the hand, wrist, and arm stresses associated with mechanical push buttons. They require absolutely no physical pressure to operate. LED indicators light for "power on" and "output activated".

LTBs are highly resistant to EMI, RFI, and ambient light interference, and are constructed from black polysulfone (or red Lexan®) and VALOX® for reliability in industrial environments. The 30-mm threaded base provides easy mounting, and LTBs are easily retrofitted to existing machines. See the listings on pages 2 and 3 for available models.

## Specifications

**Supply Voltage:** 105 to 130V ac or 210 to 250V ac, depending upon model. See listings of available models, pages 2 and 3.

**Output Configuration:** All models have SPDT electromechanical relay (one N.O. contact, one N.C. contact).

**Output Rating:** *Maximum voltage* is 250V ac or 30V dc.

*Maximum current* 7 amps (resistive load), 1 HP max.

*Minimum load* .05 watts (dc), .05VA (ac).

*Mechanical life of relay* 50,000,000 operations (min.).

*Electrical life of relay* 100,000 operations (min.) at full resistive load.

*Transient suppression is recommended when switching inductive loads.*

**Ambient Light Immunity:** 120,000 lux (direct sunlight).

**EMI/RFI Immunity:** The OPTO-TOUCH is highly resistant to both single and mixed EMI and RFI noise sources.

**Operating Temperature Range:** -20 to +50°C (-4 to +122°F).

**Indicator LEDs:** Two indicator LEDs. One lights when power is "on"; the other lights when the infrared sensing beam is interrupted.

### Construction:

Black polysulfone or red Lexan® upper housing and fiber-reinforced VALOX® base. Electronics fully epoxy-encapsulated. Totally sealed, non-metallic enclosure. The LTB's threaded base has M30 x 1.5 external threads and 1/2" NPSM internal threads. The base requires a 1-3/16" diameter mounting hole (fits most standard automotive-size "jumbo" legend plates and oiltight pushbutton holes). OPTO-TOUCH LTBs are rated NEMA 1, 3, 4, 4X, 12, and 13.

*LTB Series Alternate Action  
Optical Touch Button (QD model shown)*



 E71083

 LR41887-24

 ISO 9002  
DOCUMENTED QUALITY

**Cable:** *Quick-disconnect (QD) models* require model MBCC-512 5-conductor mini-type cable (p/n 25496), purchased separately. QD cables are 12 feet long. *Models with attached cable* (non-QD models) are supplied with 6 feet of PVC-jacketed, 22 AWG 5-conductor cable.

**Environmental Considerations** (models with polysulfone housing):

*Prolonged exposure of the OPTO-TOUCH to direct outdoor sunlight* will cause embrittlement of the polysulfone housing. Window glass effectively filters longer wavelength ultraviolet and provides excellent protection from sunlight. Contact the factory Application Engineering Department regarding outdoor applications. *Clean periodically* using a mild soap solution and a soft cloth. *Avoid the following substances*, as they will attack polysulfone to varying degrees: esters, ketones, aromatic hydrocarbons, chlorinated hydrocarbons, and strong alkaline materials.

**Environmental Considerations** (models with Lexan® housing):

*Prolonged exposure of the OPTO-TOUCH to hot water and moist high-temperature environments* above 150°F (66°C) should be avoided. *Aromatic hydrocarbons* (such as xylene and toluene), *halogenated hydrocarbons*, and *strong alkalis* should be avoided. Clean periodically using mild soap solution and a soft cloth.



**Read all WARNINGS carefully.**



**WARNING.** Banner OPTO-TOUCH™ LTB Series Optical Touch Buttons are intended as general-purpose initiators, and are *not* safety devices. Like most solid-state devices, they are as equally likely to fail in the conducting ("on") state as in the non-conducting ("off") state. If OPTO-TOUCH Optical Touch Buttons are used to initiate machines or operations in which false operation of an Optical Touch Button could be dangerous, *point-of-operation guarding devices* or related safety controls must be installed and maintained to meet all appropriate OSHA regulations and ANSI B11 machine safety standards.

NOTE: In addition to the standards and regulations mentioned above, there are numerous regulations and machine safety standards that apply to specific industries. For assistance in obtaining copies of any of these standards, contact Banner at the address and or numbers listed at the bottom of page 4.

# LTB Series *Alternate Action* OPTO-TOUCH

## Model Listing and Hookup Information

(all models have SPDT electromechanical relay output)

Models*	Operating voltage, cabling
LTBA5(L)	120V ac, 6-foot attached cable
LTBA5(L)QD	120V ac, 5-pin quick-disconnect base
LTBB5(L)	240V ac, 6-foot attached cable
LTBB5(L)QD	240V ac, 5-pin quick-disconnect base

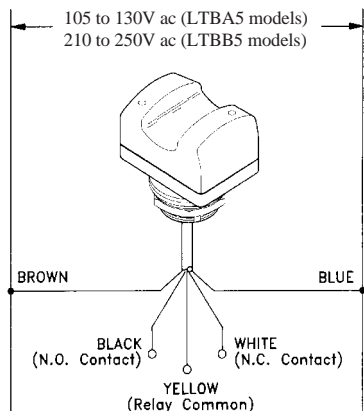

\*"L" in model suffix indicates Lexan® upper housing. See listing, page 3.

## Quick Disconnect (QD) Option

(order model MBCC-512 mini-type cable, 12-foot length, p/n 25496)

Cable connector, end view  
(MBCC-512 cable):

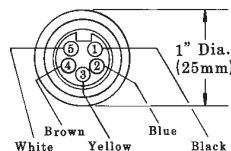

Cable connector, side view  
(MBCC-512 cable):

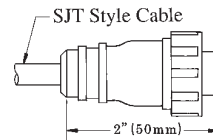

LTB base,  
quick-disconnect  
models,  
side and  
end views:

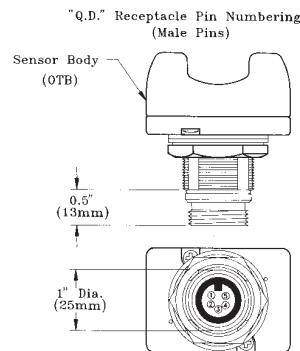

## OPTO-TOUCH LTB Mounting Hole Information

The OPTO-TOUCH has a 30 millimeter threaded base which fits directly into a standard mounting hole for an oiltight push button. A lock ring, supplied with each OPTO-TOUCH, may be used to prevent switch rotation.

The mounting hole details shown at the right are used for the OPTO-TOUCH and also for standard oiltight push buttons and their legend plates. The drawing at the far right shows how to approximate the keyway using a drill hole.

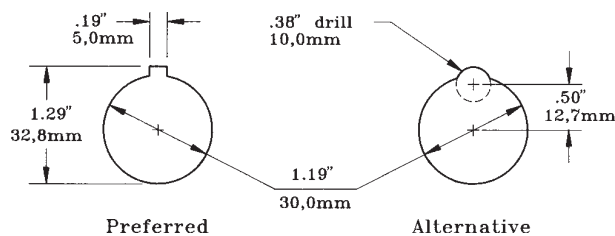

## Model SMB30S Swivel Mount Bracket

The model SMB30S swivel-mount bracket (p/n 33204) is a versatile means for mounting a Banner OPTO-TOUCH Optical Touch Button. The SMB30S lets you *ergonomically position* the OPTO-TOUCH on most machinery for maximum operator comfort and convenience.

The SMB30S mounts by its base. Its swivel ball locks snugly in place when its two clamping bolts are tightened. Bracket material is black VALOX®. Hardware is stainless steel, and mounting bolts are included.

The photo at the right shows a model SMB30S bracket with an OPTO-TOUCH attached.



### WARNING!

Never use an OPTO-TOUCH Optical Touch Button as an actuator in an emergency stop (E-Stop) circuit. E-Stop actuators must be purely mechanical devices that require no power to operate. OPTO-TOUCH Optical Touch Buttons require power to operate and **must not be used as E-Stop actuators under any circumstances.**

# LTB Series *Alternate Action* OPTO-TOUCH

## Dimensions

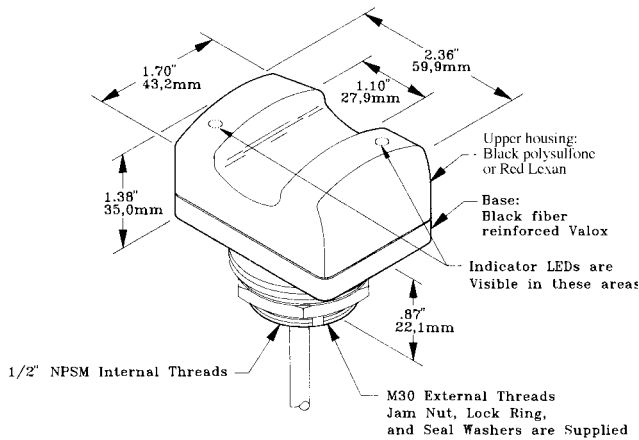

Indicator LED States:  
LED 1 turns ON when the unit is powered up  
LED 2 follows the action of the output

Model shown has built-in, attached cable.  
See page 2 for QD-style base.

Lexan® and VALOX® are registered trademarks of General Electric Company.

## OPTO-TOUCH Field Covers

OPTO-TOUCH Field Covers (see drawing, below) are designed to prevent inadvertent activation of OPTO-TOUCHs due to objects (loose clothing, debris, etc.) which might accidentally block the sensing beam.

Field covers are constructed of rugged polycarbonate-PET polyester blend, which is capable of absorbing high impacts, even at low temperatures. This material is highly resistant to abrasion and to damage by most chemicals.

Every OPTO-TOUCH is supplied with a black field cover, as standard. Field covers are available separately in four colors, which can be used to differentiate touch button functions when several touch buttons are in use:

**Black** OTC-1-BK, p/n 30221      **Yellow** OTC-1-YW, p/n 30978  
**Red** OTC-1-RD, p/n 30977      **Green** OTC-1-GN, p/n 30979

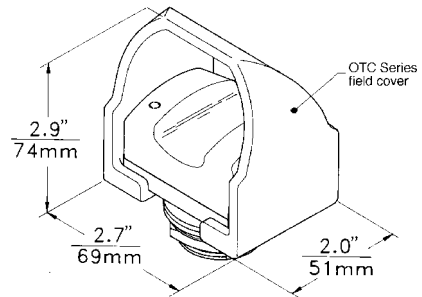

## Safety Instruction

A field cover has been supplied with this OTB. It should be installed, as shown in the drawing above, to minimize the possibility of unintended switch operation. If this cover is missing or has become lost or damaged, contact Banner immediately at (612) 544-3164 for a no-charge replacement.

**Ordering Information:** OPTO-TOUCH Optical Touch Buttons are shipped with a black field cover, as standard. A black field cover will be received if the OPTO-TOUCH is ordered by its model number (only). Red, yellow, or green field cover may be specified instead by ordering the OPTO-TOUCH using the appropriate 5-digit part number from the table, below. Field covers may also be ordered separately (above).

					<b>OPTO-TOUCH Optical Touch Buttons Part Numbers - Alternate Action Models</b>						
	120V ac	220/240V ac	Attached 6-foot cable	Quick disconnect	Polysulfone upper housing	Lexan® upper housing	Model	Black Cover	Red Cover	Yellow Cover	Green Cover
●		●		●			LTBA5	28455	35119	35127	35135
●			●	●			LTBA5QD	28456	35120	35128	35136
●		●			●		LTBA5L	34950	35121	35129	35137
●			●		●		LTBA5LQD	35010	35122	35130	35138
	●	●		●			LTBB5	28457	35123	35131	35139
	●		●	●			LTBB5QD	28458	35124	35132	35140
	●	●			●		LTBB5L	34951	35125	35133	35141
	●		●		●		LTBB5LQD	35118	35126	35134	35142

NOTE: Banner Optical Touch Buttons are manufactured and sold under license for U. S Patent #4,939,358.

# OPTO-TOUCH™ OTB Series

*Momentary Action Optical Touch Buttons*



Banner Optical Touch Buttons are **touch-activated photoelectric switches designed to replace capacitive touch switches and mechanical push buttons.** The OPTO-TOUCH's SPDT electromechanical relay or solid-state output (depending upon model) is activated for as long as a finger, introduced into the "touch area" (yoke) of the switch, interrupts the OPTO-TOUCH's infrared sensing beam.

Banner Optical Touch Buttons are ergonomically designed to eliminate the hand, wrist, and arm stresses associated with mechanical push buttons. They require absolutely no physical pressure to operate. LED indicators light for "power on" and "output activated".

All models are highly resistant to EMI, RFI, and ambient light interference. OTBs have either a black polysulfone (or red Lexan®) upper housing and VALOX® base. Lexan® models have the letter "L" in their model number suffix. Environmental considerations for use of the two types differ; see specifications below. The 30-mm threaded base on all models provides easy mounting, and Banner Optical Touch Buttons are easily retrofitted to existing machines. See pages 2 and 5 for model listings.

## Specifications

**Supply Voltage:** Models for 105 to 130V ac, 210 to 250V ac (50/60 Hz), 10 to 30V dc, or 20 to 30V ac/dc (at 25 mA, exclusive of load).

### Output Configuration:

**AC and ac/dc models:** All models have SPDT electromechanical relay (one N.O. contact, one N.C. contact).

### DC-only models:

OTBVN6 models have complementary NPN sinking outputs; OTBVP6 models have complementary PNP sourcing outputs.

### Output Rating:

**AC and ac/dc models:** Maximum voltage is 250V ac or 30V dc.

Maximum current is 7 amps (resistive load), 1 HP max.

Minimum load is .05 watts (dc), .05VA (ac).

Mechanical life of relay is 50,000,000 operations (minimum).

Electrical life of relay is 100,000 operations (min.) at full resistive load.

Transient suppression recommended when switching inductive loads.

**DC models:** 150 mA maximum load (each output).

**Ambient Light Immunity:** 120,000 lux (direct sunlight).

**EMI/RFI Immunity:** The OPTO-TOUCH is highly resistant to both single and mixed EMI and RFI noise sources.

**Operating Temperature Range:** -20 to +50°C (-4 to +122°F).

**Indicator LEDs:** Two indicator LEDs. One lights whenever power is "on"; the other lights whenever the output relay is activated.

**Construction:** Black polysulfone (or red Lexan®) upper housing and fiber-reinforced VALOX® base. Electronics fully epoxy-encapsulated. Totally sealed, non-metallic enclosure. Threaded base has

*OTB Series Momentary Action  
Optical Touch Button (QD model shown)*

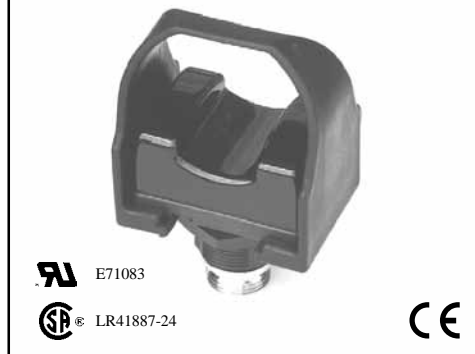

**ISO9002**  
DOCUMENTED QUALITY

M30 x 1,5 external threads and 1/2" NPSM internal threads. Base requires a 1-3/16" diameter mounting hole (fits most standard automotive-size "jumbo" legend plates and oiltight pushbutton holes). Supplied with a field cover of polycarbonate-PET polyester. OPTO-TOUCH OTBs are rated NEMA 1, 3, 4, 4X, 12, and 13.

**Cable:** DC-only Quick-disconnect (QD) models require model MBCC-412 4-conductor mini-type cable (p/n 25226); AC and ac/dc Quick-disconnect (QD) models require MBCC-512 5-conductor cable (p/n 25496; cables are purchased separately). Mini-type QD cables are 12 feet long. Models with attached cable (non-QD models) are supplied with 6 feet of PVC-jacketed, 22 AWG 4- or 5-conductor cable.

**Environmental Considerations** (models with polysulfone housing): Prolonged exposure of the OPTO-TOUCH to direct outdoor sunlight will cause embrittlement of the polysulfone housing. Window glass effectively filters longer wavelength ultraviolet and provides excellent protection from sunlight. Contact the factory Application Engineering Department regarding outdoor applications.

**Environmental Considerations** (models with Lexan® housing): Prolonged exposure of the OPTO-TOUCH to hot water and moist high-temperature environments above 150°F (66°C) should be avoided. Aromatic hydrocarbons (such as xylene and toluene), halogenated hydrocarbons, and strong alkalis should be avoided. Clean periodically using mild soap solution and a soft cloth. Avoid strong alkaline materials.



**Read all WARNINGS carefully.**



**WARNING.** Banner OPTO-TOUCH™ OTB and OTBL Series Optical Touch Buttons are intended as general-purpose initiators, and are *not* safety devices. Like most solid-state devices, they are as equally likely to fail in the conducting ("on") state as in the non-conducting ("off") state. If OPTO-TOUCH Optical

Touch Buttons are used to initiate machines or operations in which false operation of an Optical Touch Button could be dangerous, *point-of-operation guarding devices* or related safety controls must be installed and maintained to meet all appropriate OSHA regulations and ANSI B11 machine safety standards.

# OTB Series *Momentary Action* OPTO-TOUCH

## Hookup Information and Model Listing

**10-30V DC models** (see page 5 for ordering information)

Add "L" to specify Lexan® upper housing (others are polysulfone); "QD" in model suffix indicates Quick Disconnect base.

### OTBVN6(L) and OTBVN6(L)QD

*complementary sinking outputs*

Model OTBVN6(L)QD requires MBCC-412 cable (p/n 25226, purchase separately).

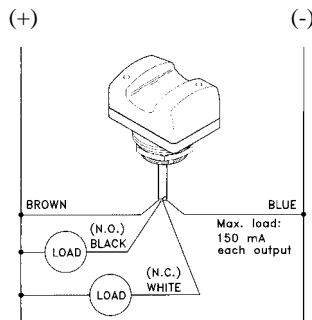

### OTBVP6(L) and OTBVP6(L)QD

*complementary sourcing outputs*

Model OTBVP6(L)QD requires MBCC-412 cable (p/n 25226, purchase separately).

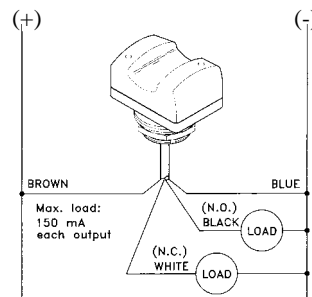

## Hookup Information and Model Listing

**AC and AC/DC models** (see page 5 for ordering information)

Add "L" to specify Lexan® upper housing (others are polysulfone); "QD" in model suffix indicates Quick Disconnect base.

### Models

- OTBA5(L)** 120V ac, SPDT electromechanical relay output, 6-foot attached cable
- OTBA5(L)QD** 120V ac, SPDT electromechanical relay output, QD base (use MBCC-512 cable)
- OTBB5(L)** 220/240V ac, SPDT electromechanical relay output, 6-foot attached cable
- OTBB5(L)QD** 220/240V ac, SPDT electromechanical relay output, QD base (use MBCC-512 cable)
- OTBVR81(L)** 20-30V ac or dc\*, SPDT electromechanical relay output, 6-foot attached cable
- OTBVR81(L)QD** 20-30V ac or dc\*, SPDT electromechanical relay output, QD base (use MBCC-512 cable)

QD models require model MBCC-512 cable (p/n 25496, purchase separately).

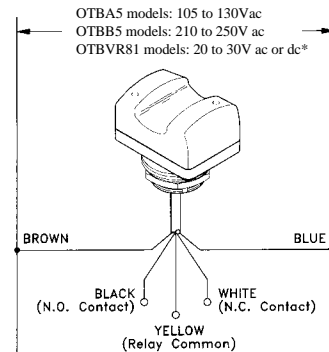

\*20-30V dc power may be applied without regard to polarity

### Quick Disconnect (QD) Option (order model MBCC-412 or MBCC-512 mini-type cable)

Cable connector end view, MBCC-412 cable (p/n 25226), for dc-only models

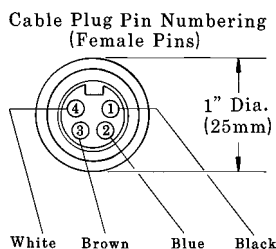

Cable connector end view, MBCC-512 cable (p/n 25496), for ac and ac/dc models

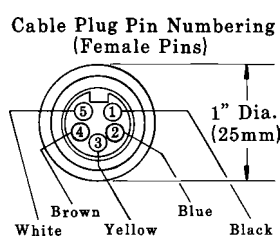

### SJT-type cable, 12 foot lengths

Cable connector, side view (MBCC-412 and MBCC-512 cable)

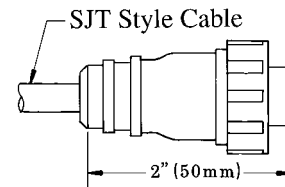

**The model SMB30S swivel-mount bracket (p/n 33204)** is a versatile means for mounting a Banner OPTO-TOUCH Optical Touch Button. The SMB30S lets you *ergonomically position* the OPTO-TOUCH on most machinery for maximum operator comfort and convenience.

The SMB30S mounts by its base. Its swivel ball locks snugly in place when its two clamping bolts are tightened. Bracket material is black VALOX®. Hardware is stainless steel, and mounting bolts are included.

The photo shows a model SMB30S bracket with an OPTO-TOUCH attached.

# OTB Series *Momentary Action* OPTO-TOUCH

## OPTO-TOUCH base

4-pin QD base (dc models)

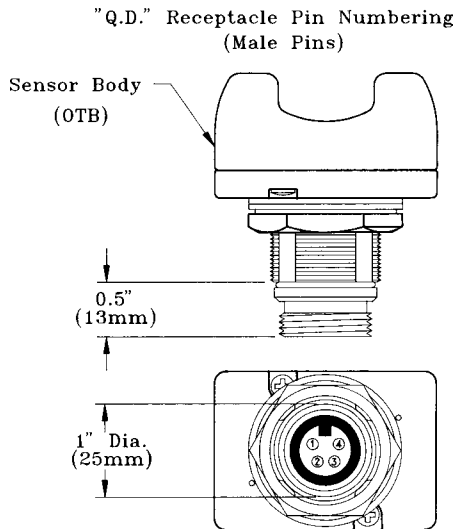

## OPTO-TOUCH base

5-pin QD base (ac and ac/dc models)

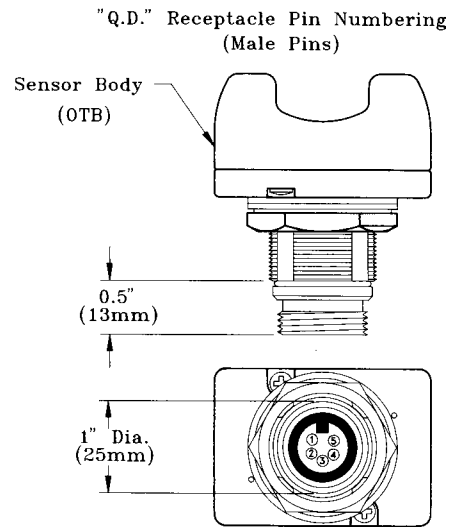

## Dimensions (see also QD base, shown above)

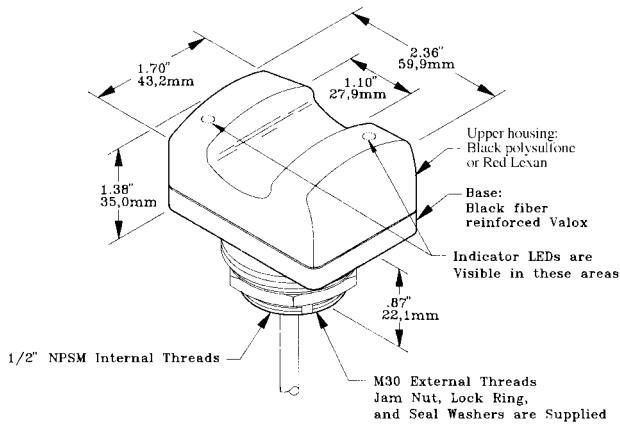

Indicator LED States:  
LED 1 turns ON when the unit is powered up  
LED 2 follows the action of the output

VALOX® and Lexan® are registered trademarks of General Electric Company.

## OPTO-TOUCH Field Covers

OPTO-TOUCH Field Covers (see drawing, below) are designed to prevent inadvertent activation of OPTO-TOUCHs due to objects (loose clothing, debris, etc.) which might accidentally block their sensing beam.

Field covers are constructed of rugged polycarbonate-PET polyester blend, which is capable of absorbing high impacts (even at low temperatures). This material is highly resistant to abrasion and to damage by most chemicals.

Every OPTO-TOUCH is supplied with a black field cover, as standard. Field covers are available separately in four colors, which can be used to differentiate touch button functions when several touch buttons are in use:

- Black** model OTC-1-BK, p/n 30221
- Red** model OTC-1-RD, p/n 30977
- Yellow** model OTC-1-YW, p/n 30978
- Green** model OTC-1-GN, p/n 30979

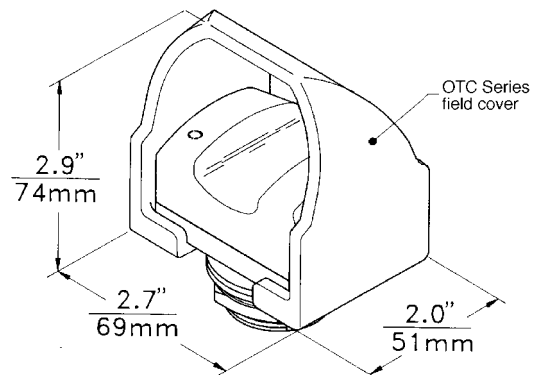

## Safety Instruction

A field cover has been supplied with this OPTO-TOUCH. It should be installed, as shown in the drawing at the right, to minimize the possibility of unintended switch operation. If this cover is missing or has become lost or damaged, contact Banner immediately at (612) 544-3164 for a no-charge replacement.

## Important Application Information

### Use of OPTO-TOUCH Optical Touch Buttons for Two-hand Machine Trip Controls Requirements for Anti-tiedown Circuitry

Two-hand trip control has been a popular means for actuation of single-stroke presses and other single-cycle machinery for many years. Optical touch buttons (OTBs) provide an ergonomic (stress-free) alternative to conventional mechanical push buttons used as actuators in two-hand trip controls.

#### OSHA Requirement for Anti-tiedown Control

Use of OTBs for two-hand trip machine actuation must include "anti-tiedown" control to prevent any means of defeating one or both actuators to create a one-hand trip. Federal law mandates the use of anti-tiedown control when two-hand trip actuators are used for cycle initiation of a single stroke part revolution clutched mechanical power press. OSHA Code of Federal Regulation, 7-1-92 Edition, CFR Title 29, Part 1910.217 (b) (6) (i) states:

*"A two-hand trip shall have the individual operator's hand controls protected against unintentional operation and have the individual operator's hand controls arranged by design and construction and/or separation to require the use of both hands to trip the press and use a control arrangement requiring concurrent operation of the individual operator's hand controls."*

Concurrent or "synchronous" actuation of two-hand trips is the most popular approach to anti-tiedown control. European Standard prEN 574, titled "Safety of Machinery - Two-handed Control Device", defines synchronous actuation as follows:

#### *"6.7 Synchronous actuations*

*In synchronous actuation an output signal shall be generated only when both control actuating devices are actuated - in a time which is less than or equal to 0.5 seconds...*

*... If the control actuating devices are not actuated synchronously the output signal shall be prevented and it shall be necessary to release both control actuating devices and to reinitiate both input signals."*

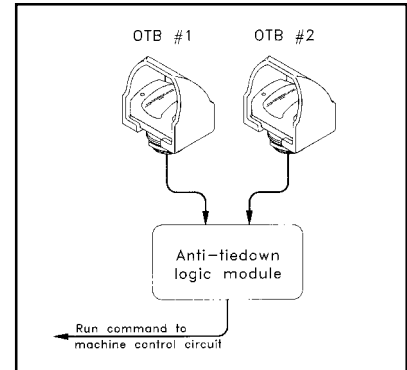

### WARNING !



In the United States, the functions that a two-hand control device is intended to perform are regulated by the Occupational Safety and Health Administration (OSHA). Whether or not any particular two-hand control system installation meets all applicable OSHA requirements depends upon the details of how the two-hand control device is applied, installed, operated, and maintained.

When properly installed, a two-hand control device using OPTO-TOUCH OTB Series Optical Touch Buttons can provide protection only for the hands of the machine operator, and is not a point of operation personnel guarding device, as defined by OSHA regulations. It is necessary to install point of operation guarding devices, such as safety light curtains and/or hard guards, to protect personnel from dangerous machine motion.

### WARNING!



Never use an OPTO-TOUCH Optical Touch Button as an actuator in an emergency stop (E-Stop) circuit. E-Stop actuators must be purely mechanical devices that require no power to operate. OPTO-TOUCH Optical Touch Buttons require power to operate and **must not be used as E-Stop actuators under any circumstances.**

**NOTE:** In addition to the standards and regulations mentioned above, there are numerous regulations and machine safety standards that apply to specific industries. For assistance in obtaining copies of any of these standards, contact Banner at the address or numbers listed at the bottom of page 6.

# Important Application Information

## Prevention of False Actuation

Any anti-tiedown control must be designed to prevent accidental actuation. Anti-tiedown circuitry must be designed to ignore false input signals. False signals include (but are not limited to) voltage transients, contact "bounce", and EMI or RFI "noise". If a PLC or any other solid-state controller is used to provide anti-tiedown, the design must assure that short duration signals (typically any signals less than a few milliseconds) are ignored. There are several manufacturers of anti-tiedown logic modules which include circuitry to minimize the possibility of false actuation.

Definitions:

*Two-hand Trip (Control):* A control that requires the operation of two separate control actuating devices by a machine operator's hands for initiation of a machine cycle.

*Anti-tiedown (Control):* A two-hand trip control configured so that both of the operator's hands must be removed and then reapplied to the control actuating devices to start another machine cycle. (Also called "anti-defeat" control.)

**Ordering Information:** OPTO-TOUCH Optical Touch Buttons are shipped with a black field cover, as standard. A black field cover will be received if the OPTO-TOUCH is ordered by its model number (only). Red, yellow, or green field cover may be specified instead by ordering the OPTO-TOUCH using the appropriate 5-digit part number from the table, below. Field covers may also be ordered separately (page 3).

										<b>OPTO-TOUCH Optical Touch Buttons Part Numbers - Momentary Action Models</b>					
120V ac	220/240V ac	20-30V ac or dc	10-30V dc	SPDT relay	NPN (sinking)	PNP (sourcing)	Attached 6-foot cable	Quick disconnect	Polysulfone upper housing	Lexan® upper housing	Model	Black Cover	Red Cover	Yellow Cover	Green Cover
●					●			●			OTBA5	27986	35058	35078	35098
	●				●			●			OTBB5	27987	35062	35082	35102
		●			●			●			OTBVR81	33080	35066	35086	35106
			●			●		●			OTBVN6	28591	35070	35090	35110
			●				●	●			OTBVP6	28589	35074	35094	35114
●					●			●	●		OTBA5QD	28149	35059	35079	35099
	●				●			●	●		OTBB5QD	28150	35063	35083	35103
		●			●			●	●		OTBVR81QD	34078	35067	35087	35107
			●			●		●	●		OTBVN6QD	28585	35071	35091	35111
			●				●	●	●		OTBVP6QD	28590	35075	35095	35115
●					●			●		●	OTBA5L	32167	35060	35080	35100
	●				●			●		●	OTBB5L	32254	35064	35084	35104
		●			●			●		●	OTBVR81L	34040	35068	35088	35108
			●			●		●		●	OTBVN6L	33706	35072	35092	35112
			●				●	●		●	OTBVP6L	34110	35076	35096	35116
●					●			●		●	OTBA5LQD	32255	35061	35081	35101
	●				●			●		●	OTBB5LQD	32256	35065	35085	35105
		●			●			●		●	OTBVR81LQD	34041	35069	35089	35109
			●			●		●		●	OTBVN6LQD	35057	35073	35093	35113
			●				●	●		●	OTBVP6LQD	34997	35077	35097	35117

**NOTE:** Banner Optical Touch Buttons are manufactured and sold under license for U. S Patent #4,939,358.

**WARRANTY:** Banner Engineering Corporation warrants its products to be free from defects for one year. Banner Engineering Corporation will repair or replace, free of charge, any product of its manufacture found to be defective at the time it is returned to the factory during the warranty period. This warranty does not cover damage or liability for the improper application of Banner products. This warranty is in lieu of any other warranty either expressed or implied.

# OPTO-TOUCH™ OTBVR81 Series

## Momentary Action 20-30V ac or dc Optical Touch Buttons



Banner **OTBVR81 Series** Optical Touch Buttons are **touch-activated photoelectric switches designed to replace capacitive touch switches and mechanical push buttons**. The OPTO-TOUCH's SPDT electromechanical relay is activated for as long as a finger, introduced into the "touch area" (yoke) of the switch, interrupts the OTB's infrared sensing beam.

Banner OTBs are ergonomically designed to eliminate the hand, wrist, and arm stresses associated with mechanical push buttons. They require absolutely no physical pressure to operate. LED indicators light for "power on" and "output activated".

OTBs are highly resistant to EMI, RFI, and ambient light interference, and are constructed from black polysulfone and VALOX® for reliability in industrial environments. The 30-mm threaded base provides easy mounting, and OTBs are easily retrofitted to existing machines. See page 2 for available models.

OTBVR81 Series Momentary Action Optical Touch Button (QD model shown)



### Specifications

**Supply Voltage:** 20 to 30V ac or dc (25 milliamps, maximum).

#### Output Configuration

All models SPDT electromechanical relay (one N.O. contact, one N.C. contact).

#### Output Rating

Maximum voltage is 250V ac or 30V dc. Maximum current 7 amps (resistive load), 1 HP max. Minimum load 100mA at 24V. Mechanical life of relay 50,000,000 operations (minimum). Electrical life of relay 100,000 operations (min.) at full resistive load. Transient suppression is recommended when switching inductive loads.

**Ambient Light Immunity:** 120,000 lux (direct sunlight).

**EMI/RFI Immunity:** The OPTO-TOUCH is highly resistant to both single and mixed EMI and RFI noise sources.

**Operating Temperature Range:** -20 to +50°C (-4 to +122°F).

**Indicator LEDs:** two indicator LEDs. One lights when power is "on"; the other lights when the infrared sensing beam is interrupted.

**Construction:** Black polysulfone cover and fiber-reinforced VALOX® base. Electronics fully epoxy-encapsulated. Totally sealed, non-metallic enclosure. The OTB's threaded base has M30 x 1,5 external threads and 1/2" NPSM internal threads. Base requires a 1-3/16" diameter mounting hole (fits most standard automotive-size "jumbo" legend plates and oiltight pushbutton holes). OPTO-TOUCH OTBs are rated NEMA 1, 3, 4, 4X, 12, and 13.

**Cable:** Quick-disconnect (QD) models require model MBCC-512 5-conductor cable (purchased separately). QD cables are 12 feet long. Models with attached cable (non-QD models) are supplied with 6 feet of PVC-jacketed, 22 AWG 5-conductor cable.

#### Environmental Considerations:

Prolonged exposure of the OPTO-TOUCH to direct outdoor sunlight will cause embrittlement of the polysulfone cover. Window glass effectively filters longer wavelength ultraviolet and provides excellent protection from sunlight. Where protection from direct sunlight is not possible, consider special-order models with Lexan® covers (see the other side of this sheet for information).

#### Cleaning Information:

OPTO-TOUCHs should be cleaned periodically using alcohol, glass cleaner, or a mild soap solution and a soft cloth. Avoid the following substances, as they will attack polysulfone to varying degrees: esters, ketones, aromatic hydrocarbons, and chlorinated hydrocarbons.

### Dimensions

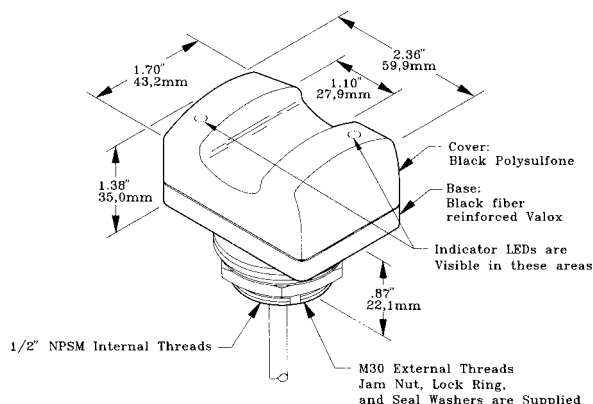

**Indicator LED States:**  
LED 1 turns ON when the unit is powered up  
LED 2 follows the action of the output

Model shown has built-in, attached cable. See page 2 for QD-style base.  
Lexan® VALOX® are registered trademarks of General Electric Company.



**WARNING.** Banner OPTO-TOUCH™ OTB Series Optical Touch Buttons are intended as general-purpose initiators, and are *not* safety devices. Like most solid-state devices, they are as equally likely to fail in the conducting ("on") state as in the non-conducting ("off") state. If OPTO-TOUCH Optical Touch Buttons are used to initiate machines or operations in which false operation of an Optical Touch Button could be dangerous, *point-of-operation guarding devices* or related safety controls must be installed and maintained to meet all appropriate OSHA regulations and ANSI B11 machine safety standards.

## OPTO-TOUCH OTB Mounting Hole Information

The OPTO-TOUCH has a 30 millimeter threaded base which fits directly into a standard mounting hole for an oiltight push button. A lock ring, supplied with each OPTO-TOUCH, may be used to prevent switch rotation.

The mounting hole details shown at the right are used for the OPTO-TOUCH and also for standard oiltight push buttons and their legend plates. The drawing at the far right shows how to approximate the keyway using a drill hole.

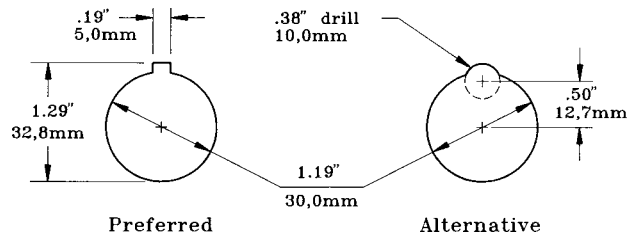

### Quick Disconnect (QD) Option (order model MBCC-512 cable)

Cable connector, end view (MBCC-512 cable):

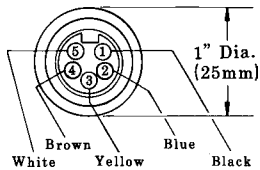

Cable connector, side view (MBCC-512 cable):

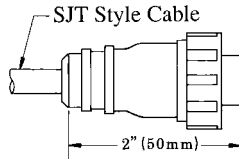

OTB base, side and end views:

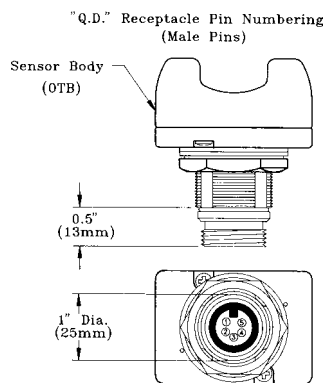

### Hookup Information:

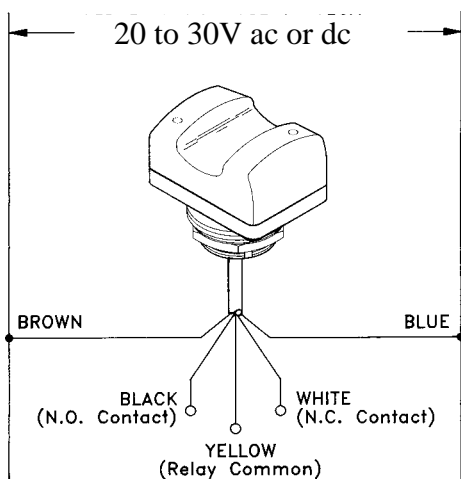

NOTE: dc power is applied without regard to polarity.

### Standard models with polysulfone cover

#### Models

OTBVR81 Standard model with polysulfone cover and 6-foot attached cable.

OTBVR81QD Standard model with polysulfone cover and QD-style base (requires MBCC-512 cable).

### Special-order models with Lexan® cover

OTBs with Lexan® cover are available by special order for use in direct sunlight. Lexan® models should be avoided for certain environments, as explained below.

#### Models

OTBVR81L Special model with Lexan® cover and 6-foot attached cable.

OTBVR81LQD Special model with Lexan® cover and QD-style base (requires MBCC-512 cable).

### Environmental Considerations for Lexan® models:

*Prolonged exposure to hot water and moist high-temperature environments (above 150°F or 66°C) should be avoided.*

*Aromatic hydrocarbons (such as xylene and toluene), halogenated hydrocarbons, and strong alkaline materials should be avoided.*

Lexan® OPTO-Touches should be cleaned periodically using a mild soap solution and a soft cloth. Avoid strong alkaline materials, as they will attack Lexan® to varying degrees.

**WARRANTY:** Banner Engineering Corporation warrants its products to be free from defects for a period of one year. Banner Engineering Corporation will repair or replace, free of charge, any product of its manufacture found to be defective at the time it is returned to the factory during the warranty period. This warranty does not cover damage or liability for the improper application of Banner products. This warranty is in lieu of any other warranty either expressed or implied.