



# Q45 NAMUR Sensors

*Intrinsically Safe DC Sensors*

## Q45 NAMUR Sensor Features



- Intrinsically safe sensors with the rugged design and exceptional optical performance of Q45 Series sensors
- Use with approved switching amplifiers which have intrinsically safe input circuits; designed in accordance with DIN 19 234
- Output passes  $\leq 1.2$  mA in the “dark” condition and  $\geq 2.1$  mA in the “light” condition
- Internal multi-turn SENSITIVITY (Gain) control accessible beneath hinged, o-ring sealed top cover
- Choose models with integral cable or quick-disconnect connector

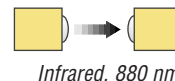
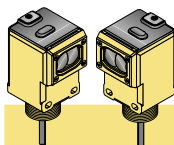

## Q45 NAMUR Opposed Mode Emitter (E) and Receiver (R)

Models	Range	Cable	Supply Voltage	Output Type	Excess Gain	Beam Pattern
Q459E	6 m (20')	2 m (6.5')	5-15V dc	Constant Current $\leq 1.2$ mA dark $\geq 2.1$ mA light		
Q459EQ		4-Pin Euro QD				
Q45AD9R		2 m (6.5')				
Q45AD9RQ		4-Pin Euro QD				

- NOTES:**
- 9 m (30') cables are available by adding suffix “W/30” to the model number of any cabled sensor (e.g., Q459E W/30).
  - A model with a QD connector requires an accessory mating cable. See page 8 for more information.



### **WARNING . . . Not To Be Used for Personnel Protection**

**Never use these products as sensing devices for personnel protection. Doing so could lead to serious injury or death.**

These sensors do NOT include the self-checking redundant circuitry necessary to allow their use in personnel safety applications. A sensor failure or malfunction can cause either an energized or de-energized sensor output condition. Consult your current Banner Safety Products catalog for safety products which meet OSHA, ANSI and IEC standards for personnel protection.

# Q45 NAMUR Sensors

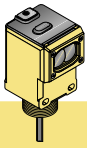

NOTE: Retroreflective range is specified using one model BRT-3 retroreflector (3-inch diameter). Actual sensing range may be more or less than specified, depending upon the efficiency and reflective area of the retroreflector(s) in use.



Visible red, 680 nm  
Non-Polarized



Polarized

## Q45 NAMUR Retroreflective Mode

Models	Range	Cable	Supply Voltage	Output Type	Excess Gain	Beam Pattern
<b>Non-Polarized</b>						
Q45AD9LV Q45AD9LVQ	9 m (30')	2 m (6.5') 4-Pin Euro QD	5-15V dc	Constant Current ≤1.2 mA dark ≥2.1 mA light		
<b>Polarized</b>						
Q45AD9LP Q45AD9LPQ	6 m (20')	2 m (6.5') 4-Pin Euro QD	5-15V dc	Constant Current ≤1.2 mA dark ≥2.1 mA light		

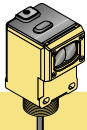

Infrared, 880 nm

## Q45 NAMUR Diffuse Mode

Models	Range	Cable	Supply Voltage	Output Type	Excess Gain	Beam Pattern
Performance based on 90% reflectance white test card						
<b>Short Range</b>						
Q45AD9D Q45AD9DQ	300 mm (12")	2 m (6.5') 4-Pin Euro QD	5-15V dc	Constant Current ≤1.2 mA dark ≥2.1 mA light		
<b>Long Range</b>						
Q45AD9DL Q45AD9DLQ	1 m (40")	2 m (6.5') 4-Pin Euro QD	5-15V dc	Constant Current ≤1.2 mA dark ≥2.1 mA light		

# Q45 NAMUR Sensors



Visible red, 680 nm

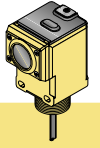

## Q45 NAMUR Convergent Mode

Models	Focus	Cable	Supply Voltage	Output Type	Excess Gain	Beam Pattern
					Performance based on 90% reflectance white test card	
<b>Q45AD9CV</b> <b>Q45AD9CVQ</b>	38 mm (1.5")  Spot Size at Focus: 1.3 mm (0.05")	2 m (6.5') 4-Pin Euro QD	5-15V dc	Constant Current $\leq 1.2$ mA dark $\geq 2.1$ mA light		
<b>Q45AD9CV4</b> <b>Q45AD9CV4Q</b>	100 mm (4")  Spot Size at Focus: 1.5 mm (0.06")	2 m (6.5') 4-Pin Euro QD	5-15V dc	Constant Current $\leq 1.2$ mA dark $\geq 2.1$ mA light		



Visible red, 660 nm

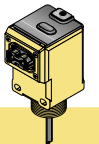

## Q45 NAMUR Plastic Fiber Optic

Models	Range	Cable	Supply Voltage	Output Type	Excess Gain	Beam Pattern
					Diffuse mode performance based on 90% reflectance white test card	
<b>Q45AD9FP</b> <b>Q45AD9FPQ</b>	Range varies by sensing mode and fiber optics used	2 m (6.5') 4-Pin Euro QD	5-15V dc	Constant Current $\leq 1.2$ mA dark $\geq 2.1$ mA light		

# Q45 NAMUR Sensors

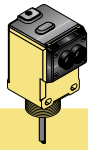





Infrared, 880 nm  
Visible red, 650 nm

## Q45 NAMUR Glass Fiber Optic

Models	Range	Cable	Supply Voltage	Output Type	Excess Gain	Beam Pattern
					Diffuse mode performance based on 90% reflectance white test card	
<b>Infrared, 880 nm</b>						
Q45AD9F Q45AD9FQ	Range varies by sensing mode and fiber optics used	2 m (6.5') 4-Pin Euro QD	5-15V dc	Constant Current ≤1.2 mA dark ≥2.1 mA light		
<b>Visible Red, 650 nm</b>						
Q45AD9FV Q45AD9FVQ	Range varies by sensing mode and fiber optics used	2 m (6.5') 4-Pin Euro QD	5-15V dc	Constant Current ≤1.2 mA dark ≥2.1 mA light		

# Q45 NAMUR Sensors

## Q45 NAMUR Specifications

<b>Supply Voltage and Current</b>	5 to 15V dc. Supply voltage is provided by the amplifier to which the sensor is connected.
<b>Output</b>	Constant current output: $\leq 1.2$ mA in the "dark" condition and $\geq 2.1$ mA in the "light" condition
<b>Output Response Time</b>	Opposed mode receiver: 2 milliseconds on/0.4 milliseconds off. All others 5 milliseconds on/off (does not include amplifier response)
<b>Adjustments</b>	Multi-turn sensitivity control on top of sensor, beneath a transparent o-ring sealed Lexan® cover, allows precise sensitivity setting (turn clockwise to increase gain).
<b>Indicators</b>	Indicator LED's are highly visible, located beneath a raised transparent Lexan® dome on top of the sensor. <b>POWER</b> (red) LED (emitters only) lights whenever 5 - 15V dc power is applied <b>SIGNAL</b> (red) LED lights whenever the sensor sees its modulated light source
<b>Construction</b>	Molded thermoplastic polyester housing, o-ring sealed transparent Lexan® top cover, molded acrylic lenses, and stainless steel hardware. Q45s are designed to withstand 1200 psi washdown. The base of cabled models has a 1/2" NPS integral internal conduit thread.
<b>Environmental Rating</b>	NEMA 6P, IEC IP67
<b>Connections</b>	PVC-jacketed 2 m (6.5') or 9 m (30') cables, or 4-pin euro-style quick-disconnect (QD) fitting are available. QD cables are ordered separately. See page 8.
<b>Operating Conditions</b>	<b>Temperature:</b> -40° to +70°C (-40° to +158°F) <b>Maximum relative humidity:</b> 90% at 50°C (non-condensing)
<b>Design Standards</b>	Q45AD9 Series sensors comply with the following standards: DIN 19 234, EN 50 014:1997, EN 50 020: 2002
<b>Certifications</b>	    

Lexan® is a registered trademark of General Electric Co.

### APPROVALS

<b>CSA:</b>	#LR 41887	Intrinsically Safe, with Entity for: Class I, Groups A-D Class I, Div. 2, Groups A-D
<b>FM:</b>	#J.I. 5Y3A4.AX	Intrinsically Safe, with Entity for: Class I, II, III, Div. 1, Groups A-G Class I, II, III, Div. 2, Groups A-D and G
<b>KEMA:</b>	#03ATEX1441X	II 1 G EEx ia IIC T6
<b>ETL:</b>	#558044	Tested per FM and CSA as shown above

### Special Conditions for Safe Use:

Parts of the enclosure are non-conducting and may generate an ignition-capable level of ESD.

Cleaning of the equipment shall be done only with a damp cloth.

# Q45 NAMUR Sensors

## Q45 NAMUR Dimensions

### NAMUR Series Opposed, Retro, and Diffuse Sensing Modes (model suffix E, R, D, DL, LP & LV)

#### Cabled

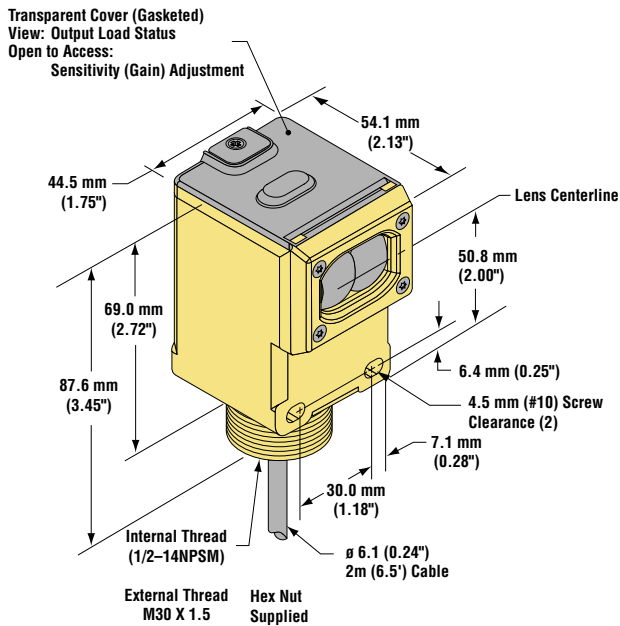

#### Quick-Disconnect 4-Pin Euro-Style

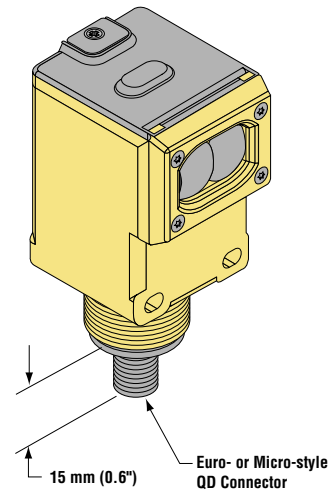

#### Convergent Sensing Mode (model suffix CV & CV4)

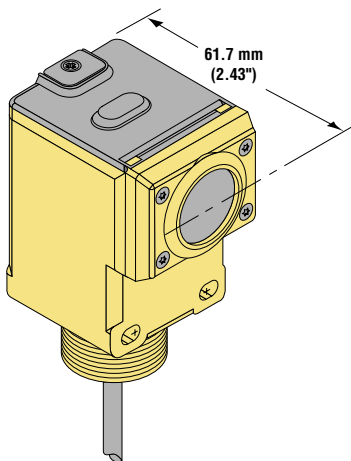

#### Glass Fiber Optic (model suffix F & FV)

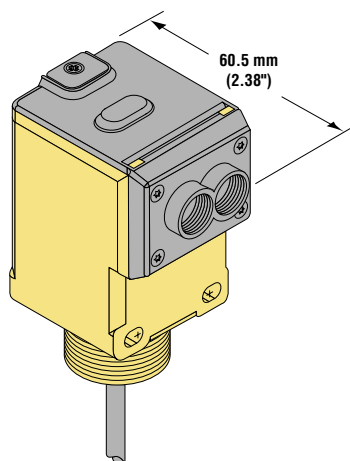

#### Plastic Fiber Optic (model suffix FP)

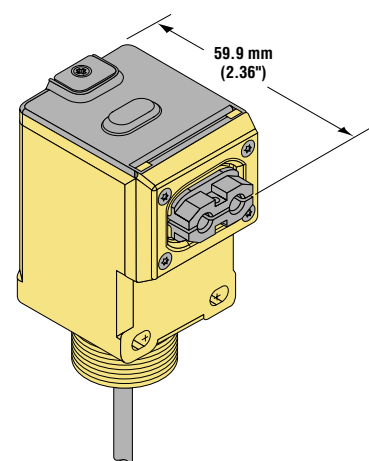

## Q45 NAMUR Hookups

### NAMUR Sensors with Attached Cable

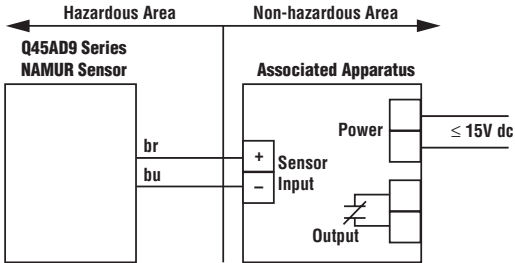

### NAMUR Sensors with Quick-Disconnect

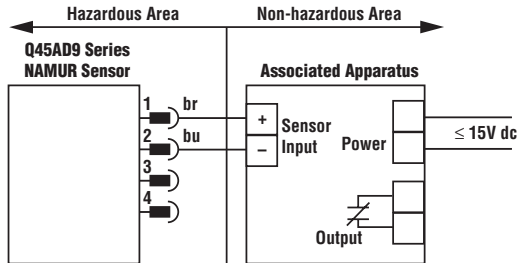

#### Entity Parameters

##### Associated Apparatus

$V_{oc} \leq 15V \text{ dc}$   
 $I_{sc} \leq 60 \text{ mA}$   
 $C_a \leq *C_{(cable)} + C_i$   
 $L_a \leq *L_{(cable)} + L_i$

##### Sensor Apparatus

$V_{max} = 15V \text{ dc}$   
 $I_{max} = 60 \text{ mA}$   
 $C_i = 300 \text{ nF}$   
 $L_i = 0$   
 $P_i = 225 \text{ mW}$

$*C_{(cable)} = 60 \text{ pF/ft}$

$*L_{(cable)} = 0.2 \text{ } \mu\text{H/ft}$

**HAZARDOUS AREA APPLICATION:**

“Associated apparatus” may include intrinsically safe amplifiers and barriers to monitor sensor supply current, which is the sensor’s output signal. Associated apparatus must limit both supply voltage and supply current in the event of failure.

### 4-Pin Euro-Style Pinout (Cable Connector Shown)

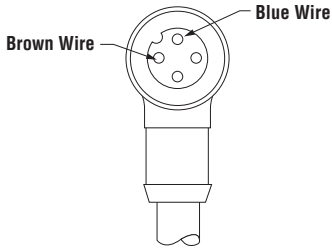

# Q45 NAMUR Sensors

## ACCESSORIES

### Modifications

Model Suffix	Modification	Description	Example of Model Number
W/30	9 m (30') cable	All Q45 Series sensors may be ordered with an integral 9 m (30') cable in place of the standard 2 m (6.5') cable	Q45AD9LV W/30

### Quick-Disconnect Cables

Following is the selection of cables available for Q45 QD models.

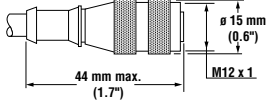
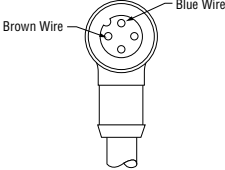
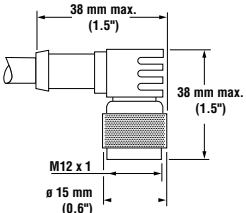
Style	Model	Length	Dimensions	Pin-out
4-Pin Euro (NAMUR)	MQD9-406 MQD9-415	2 m (6.5') 5 m (15')		
	MQD9-406RA MQD9-415RA	2 m (6.5') 5 m (15')		

### Extension Cables (without connectors)

The following cables are available for extending the length of existing sensor cable. These are 30 m (100') lengths of Q45 cable. This cable may be spliced to existing cable. Connectors, if used, must be customer-supplied.





Model	Type	Used with:
ECAD9-100	2-conductor	All NAMUR models (Q45AD9 Series)

### Replacement Lens Assemblies

Q45 Series lens assemblies are field-replaceable.

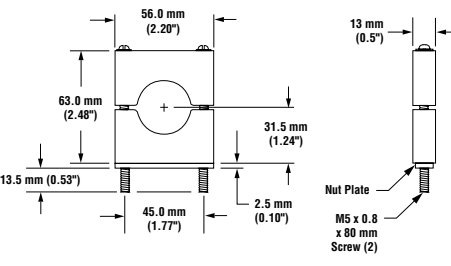
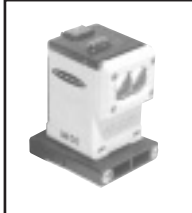
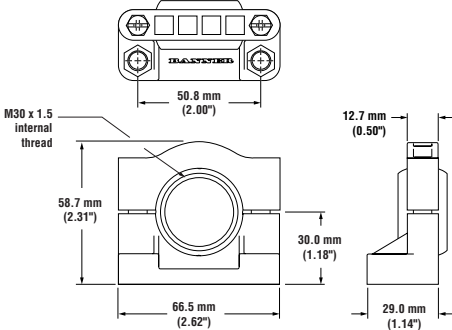
Model	Description
UC-45L	Replacement lens for E, R, DL and LV
UC-45LP	Replacement lens for LP
UC-45D	Replacement lens for D
UC-45F	Replacement lens for F and FV
UC-45FP	Replacement lens for FP
UC-45C	Replacement lens for CV
UC-45C4	Replacement lens for CV4

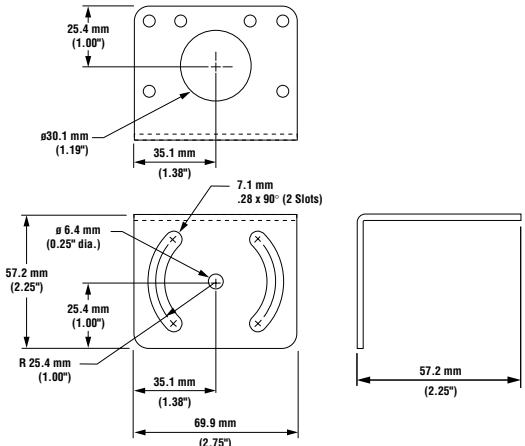
## Q45 NAMUR Mounting Brackets

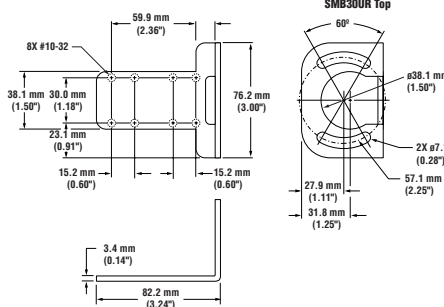
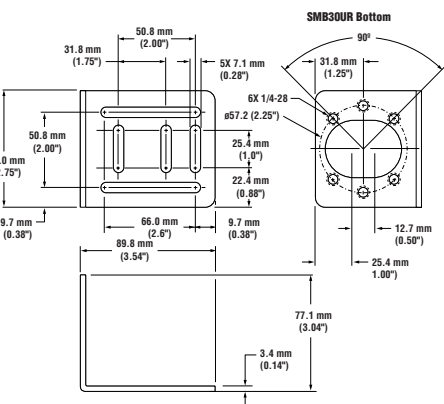
<p><b>SMB30C</b></p>	<ul style="list-style-type: none"> <li>• 30 mm split clamp bracket</li> <li>• Black reinforced thermoplastic polyester</li> <li>• Includes stainless steel mounting hardware</li> </ul>	<p><b>SMB30SC</b></p>	<ul style="list-style-type: none"> <li>• 30 mm swivel bracket</li> <li>• Black reinforced thermoplastic polyester</li> <li>• Includes stainless steel mounting and swivel locking hardware</li> </ul>
			
<p><b>SMB30MM</b></p>	<ul style="list-style-type: none"> <li>• 30 mm, 12-gauge, stainless steel bracket with curved mounting slots for versatility and orientation</li> <li>• Clearance for M6 (1/4") hardware</li> </ul>	<p><b>SMB30UR</b></p>	<ul style="list-style-type: none"> <li>• 2-piece universal swivel bracket for limit-switch style sensors</li> <li>• 300 series stainless steel</li> <li>• Includes stainless steel swivel locking hardware</li> </ul>
			

# Q45 NAMUR Sensors

## Quick-Disconnect (Q-suffix) Sensor, Connector View

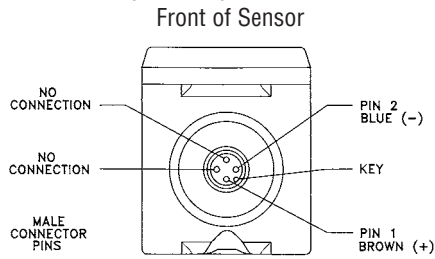

### HAZARDOUS AREA APPLICATION:

#### Entity Parameters:

Associated Apparatus may include amplifiers and barriers to monitor apparatus supply current which is the apparatus output signal. Associated apparatus must limit both supply voltage and supply current in the event of failures.

#### Associated Apparatus

$$\begin{aligned} V_{oc} &\leq 15V \text{ dc} \\ I_{sc} &\leq 60 \text{ mA} \\ C_a &\geq *C_{(cable)} + C_i \\ L_a &\geq *L_{(cable)} + L_i \end{aligned}$$

Cable Parameters (if unknown)

$$*C_{(cable)} = 60 \text{ pF/ft}$$

#### Sensor Apparatus

$$\begin{aligned} V_{max} &= 15V \text{ dc} \\ I_{max} &= 60 \text{ mA} \\ C_i &= 0.3\mu\text{F} \\ L_i &= 0 \quad P_i = 225 \text{ mW} \end{aligned}$$

$$*L_{(cable)} = 0.2 \mu\text{H/ft}$$

#### FM Installation Notes:

a) Associated Apparatus (barrier) entity parameters must meet the following requirements:

$$\begin{aligned} V_{oc} &\leq V_{max} & C_a &\geq C_i + C_{cable} \\ I_{sc} &\leq I_{max} & L_a &\geq L_i + L_{cable} \end{aligned}$$

- b) The Associated Apparatus shall not be connected to any device that uses or generates in excess of 250 Volts rms or dc.  
 c) Intrinsic safety ground, if required for the Associated Apparatus, shall be less than 1 ohm.  
 d) Installation shall be in accordance with the National Electrical Code

Sensing Mode	Model Designations & Part Numbers	
	Quick-Disconnect	2 m (6.5') Cable
Short-range Diffuse (D)	Q45AD9DQ 37627	Q45AD9D 37617
Long-range Diffuse (DL)	Q45AD9DLQ 37628	Q45AD9DL 37618
Glass Fiber Optic (F)	Q45AD9FQ 37631	Q45AD9F 37621
Glass Fiber Optic (FV)	Q45AD9FVQ 59014	Q45AD9FV 58266
Plastic Fiber Optic (FP)	Q45AD9FPQ 37632	Q45AD9FP 37622
Visible Retroreflective (LV)	Q45AD9LVQ 37630	Q45AD9LV 37620
Visible Polarized Retroreflective (LP)	Q45AD9LPQ 37629	Q45AD9LP 37619
Visible Convergent 38 mm (1.5") (CV)	Q45AD9CVQ 37633	Q45AD9CV 37623
Visible Convergent 102 mm (4") (CV4)	Q45AD9CV4Q 37634	Q45AD9CV4 37624
Emitter (E)	Q459EQ 37635	Q459E 37625
Receiver (R)	Q45AD9RQ 37636	Q45AD9R 37626

## Wiring: Cabled and Quick-Disconnect (Q-suffix) Models

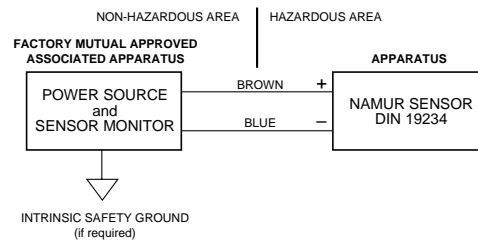

(ANSI/NFPA70), local codes, Associated Apparatus manufacturer's installation requirements and ANSI/ISA RP12.6 for hazardous (classified) location installation.

- e) Associated Apparatus is not required for installation of the devices within a Division 2 hazardous (classified) location. The maximum voltage for Division 2 installation is 15V dc.  
 f) Maximum connector torque: 6 foot-lbs

#### CSA Installation Notes:

a) Associated Apparatus (barrier) entity parameters must meet the following requirements:

$$\begin{aligned} V_{oc} &\leq V_{max} & C_a &\geq C_i + C_{cable} \\ I_{sc} &\leq I_{max} & L_a &\geq L_i + L_{cable} \end{aligned}$$

- b) The Associated Apparatus shall not be connected to any device that uses or generates in excess of 250 Volts rms or dc.  
 c) Intrinsic safety ground, if required for the Associated Apparatus, shall be less than 1 ohm.  
 d) Installation shall be in accordance with the Canadian Electrical Code, Part 1.  
 e) Associated Apparatus (barrier) shall be installed in accordance with the manufacturer's instructions.  
 f) Associated Apparatus is not required for installation of the devices within a Division 2 hazardous (classified) location when installed in, or through the wall of a suitable enclosure with provision or connection of rigid metal conduit per the Canadian Electrical Code, as acceptable to the local inspection authority having jurisdiction. The maximum rating for Division 2 installation is 15V dc, 60 mA.  
 g) In Division 2 installations, observe the following warnings:

#### WARNING: EXPLOSION HAZARD

Do not disconnect equipment unless power has been switched off or the area is known to be non-hazardous.

#### AVERTISSEMENT: RISQUE D'EXPLOSION

Avant de deconnecter l'equipment, couper le courant ou s'assurer que l'emplacement est designe non dangereux.

#### APPROVALS

**KEMA:** EN50014, EN50020, EN50284  
 DIN 19234 NAMUR  
 II 1 G EEx ia IIC T6 KEMA No. 03ATEX1441 X  
 Ta -40°C .. 70°C

**ETL:** Listed 554656

**CSA:** C22.2#157-92, 213-M1987, Exia  
 CL I DIV 1 GP A-D  
 CL I DIV 2 GP A-D – Ambient 70°C

**FM:** 3610, 3611  
 I.S. CL I, II, III DIV 1 GP A-G  
 N.I. CL I DIV 2 GP A-D (all models)  
 CL II, III DIV 2 GP F-G (cable models only)



Q45AD9 Series  
 Intrinsically Safe Sensors

Banner Engineering Corp.  
 9714 Tenth Avenue North  
 Minneapolis, MN 55441

Control Drawing #38343  
 Revision G