

Because of their extremely high excess gain, these opposed-mode sensors are an excellent option for sensing in contaminated or dirty areas, and are also the best choice for long-range sensing.

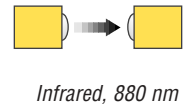

## Q45BW22 Series Features

- Advanced one-piece photoelectric sensors with outstanding optical performance and extremely rugged design
- 90 to 250V ac
- Protected solid-state relay output; 300 mA max. load at up to 250V ac
- Multiple sensing modes include: opposed, diffuse, retroreflective and convergent, plus glass and plastic fiber optic models
- Switchable light/dark operate
- Versatile plug-in modules available for output timing logic and/or signal strength display
- Highly visible Power, Signal (AID™ System\*), and Output indicator LEDs
- Choice of prewired 2 m (6.5') or 9 m (30') unterminated cable, plus Mini-style or Micro-style quick-disconnect fittings
- Versatile mounting options
- Designed to withstand 1200 psi washdown; exceeds its NEMA 6P and IEC IP67 rating

\*U.S. Patent no. 4356393

## Q45BW22 Series Opposed-Mode Emitter (E) and Receiver (R) Models

| Models   | Range       | Cable  | Supply Voltage | Output Type            | Excess Gain | Beam Pattern |
|--|-------------|--|----------------|------------------------|-------------|--------------|
| Q452E Emitter<br>Q45BW22R Receiver   | 60 m (200') | 2-wire 2m (6.5')   | 90 to 250V ac  | SPST Solid-state Relay |             |              |
| Q452EQ Emitter<br>Q452EQ1 Emitter<br>Q45BW22RQ Receiver<br>Q45BW22RQ1 Receiver |             | 3-Pin Mini-style QD<br>4-Pin Micro-style QD<br>3-Pin Mini-style QD<br>4-Pin Micro-style QD |                |                        |             |              |

NOTES: i) 9 m (30') cables are available by adding suffix "W/30" to the model number of any cabled sensor (e.g., Q452E W/30)  
ii) A model with a QD connector requires a mating cable; see page 10.

**IMPORTANT: SEE SAFETY USE WARNING ON BACK PAGE**

# Q45BW22 Series

The visible red sensing beam of these sensors makes them very easy to align. Model Q45BW22LP polarizes the emitted light and filters out unwanted reflections, making sensing possible in applications otherwise considered unsuited to retroreflective sensing. Performance is specified using the model BRT-3 3" reflector (see the Accessories section of your current Banner Photoelectric Sensors catalog for further information).

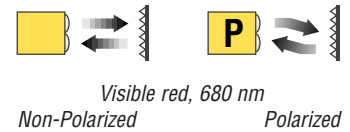
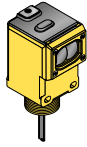

## Q45BW22 Series Retroreflective-Mode Models

| Models  | Range                      | Cable  | Supply Voltage | Output Type            | Excess Gain | Beam Pattern |
|---|----------------------------|--|----------------|------------------------|-------------|--------------|
| <b>Non-Polarized</b>  |                            |  |                |                        |             |              |
| <b>Q45BW22LV</b><br><b>Q45BW22LVQ</b><br><b>Q45BW22LVQ1</b> | 0.08 to 9 m<br>(3" to 30') | 3-wire 2 m (6.5')<br>3-Pin Mini-style QD<br>4-Pin Micro-style QD | 90 to 250V ac  | SPST Solid-state Relay |             |              |
| <b>Polarized</b>  |                            |  |                |                        |             |              |
| <b>Q45BW22LP</b><br><b>Q45BW22LPQ</b><br><b>Q45BW22LPQ1</b> | 0.15 to 6 m<br>(6" to 20') | 3-wire 2 m (6.5')<br>3-Pin Mini-style QD<br>4-Pin Micro-style QD | 90 to 250V ac  | SPST Solid-state Relay |             |              |

### NOTES:

- i) 9 m (30') cables are available by adding suffix "W/30" to the model number of any cabled sensor (e.g., **Q45BW22LV W/30**)
- ii) A model with a QD connector requires a mating cable; see page 10.

# Q45BW22 Series

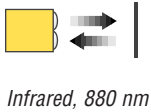

These diffuse-mode models detect objects by sensing the reflection of their own emitted light. Ideal for use when the reflectivity and profile of the object to be sensed are sufficient to return a large percentage of emitted light back to the sensor. Model Q45BW22DX is the first choice for diffuse-mode applications when there are no background objects to falsely return light.

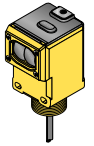

## Q45BW22 Series Diffuse-Mode Models

| Models  | Range       | Cable  | Supply Voltage | Output Type            | Excess Gain  | Beam Pattern |
|---|-------------|--|----------------|------------------------|--|--------------|
|   |             |  |                |                        | Performance based on 90% reflectance white test card |              |
| <b>Short Range</b>  |             |  |                |                        |  |              |
| <b>Q45BW22D</b><br><b>Q45BW22DQ</b><br><b>Q45BW22DQ1</b>    | 45 cm (18") | 3-wire 2 m (6.5')<br>3-Pin Mini-style QD<br>4-Pin Micro-style QD | 90 to 250V ac  | SPST Solid-state Relay |  |              |
| <b>Long Range</b>   |             |  |                |                        |  |              |
| <b>Q45BW22DL</b><br><b>Q45BW22DLQ</b><br><b>Q45BW22DLQ1</b> | 1.8 m (6')  | 3-wire 2 m (6.5')<br>3-Pin Mini-style QD<br>4-Pin Micro-style QD | 90 to 250V ac  | SPST Solid-state Relay |  |              |
| <b>High Power</b>   |             |  |                |                        |  |              |
| <b>Q45BW22DX</b><br><b>Q45BW22DXQ</b><br><b>Q45BW22DXQ1</b> | 3 m (10')   | 3-wire 2 m (6.5')<br>3-Pin Mini-style QD<br>4-Pin Micro-style QD | 90 to 250V ac  | SPST Solid-state Relay |  |              |

# Q45BW22 Series

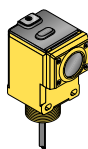

These sensors are ideal for reflective sensing of very small parts or profiles, and can accurately sense the position of parts approaching from the side. Will ignore all but highly reflective objects that are outside the sensing range.



Visible red. 680 nm

## Q45BW22 Series Convergent-Mode Models

| Models   | Focus  | Cable  | Supply Voltage | Output Type            | Excess Gain  | Beam Pattern |
|--|--|--|----------------|------------------------|--|--------------|
|  |  |  |                |                        | Performance based on 90% reflectance white test card |              |
| <b>Q45BW22CV</b><br><b>Q45BW22CVQ</b><br><b>Q45BW22CVQ1</b>    | 38 mm (1.5")<br><b>Spot Size at Focus:</b><br>1.3 mm (0.05") | 3-wire 2 m (6.5')<br>3-Pin Mini-style QD<br>4-Pin Micro-style QD | 90 to 250V ac  | SPST Solid-state Relay |  |              |
| <b>Q45BW22CV4</b><br><b>Q45BW22CV4Q</b><br><b>Q45BW22CV4Q1</b> | 100 mm (4")<br><b>Spot Size at Focus:</b><br>1.5 mm (0.06")  | 3-wire 2 m (6.5')<br>3-Pin Mini-style QD<br>4-Pin Micro-style QD | 90 to 250V ac  | SPST Solid-state Relay |  |              |

### NOTES:

- i) 9 m (30') cables are available by adding suffix "W/30" to the model number of any cabled sensor (e.g., **Q45BW22CV W/30**)
- ii) A model with a QD connector requires a mating cable; see page 10.

# Q45BW22 Series

These models are an excellent choice for glass fiber optic applications where faster sensor response is not important. Their high excess gain means that opposed individual fibers can operate reliably in many very hostile environments. Also, special miniature bifurcated fiber optic assemblies with bundle sizes as small as .5 mm (.020") dia. may be used successfully for diffuse-mode sensing when using sensor model Q45BW22F(Q). For more information on compatible glass fiber optics, refer to your current Banner Photoelectric Sensors catalog.

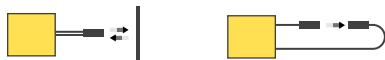
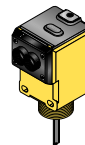

Infrared, 880 nm and Visible Red, 650 nm

## Q45BW22 Series Glass Fiber-Optic Models

| Models                                 | Range  | Cable  | Supply Voltage | Output Type            | Excess Gain   |  | Beam Pattern |  |
|--|--|--|----------------|------------------------|---|--|--------------|--|
|  |  |  |                |                        | Diffuse mode performance based on 90% reflectance white test card |  |              |  |
| <b>Infrared, 880 nm</b>                |  |  |                |                        |   |  |              |  |
| Q45BW22F<br>Q45BW22FQ<br>Q45BW22FQ1    | Range varies by sensing mode and fiber optics used | 3-wire 2 m (6.5')<br>3-Pin Mini-style QD<br>4-Pin Micro-style QD | 90 to 250V ac  | SPST Solid-state Relay |   |  |              |  |
| <b>Visible Red, 650 nm</b>             |  |  |                |                        |   |  |              |  |
| Q45BW22FV<br>Q45BW22FVQ<br>Q45BW22FVQ1 | Range varies by sensing mode and fiber optics used | 3-wire 2 m (6.5')<br>3-Pin Mini-style QD<br>4-Pin Micro-style QD | 90 to 250V ac  | SPST Solid-state Relay |   |  |              |  |

# Q45BW22 Series

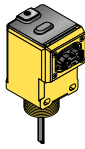

Lower in cost than glass fiber optics, plastic fiber optics are ideal for use in situations where environmental conditions allow (for example, low levels of acids, alkalis, and solvents). Most are easily cut to length in the field, and are available in a variety of sensing end styles. For more information on compatible plastic fiber optics, refer to your current Banner Photoelectric Sensors catalog.



Visible red, 660 nm



## Q45BW22 Series Plastic Fiber-Optic Models

| Models  | Range  | Cable  | Supply Voltage | Output Type            | Excess Gain   | Beam Pattern |
|---|--|--|----------------|------------------------|---|--------------|
|   |  |  |                |                        | Diffuse mode performance based on 90% reflectance white test card |              |
| <b>Q45BW22FP</b><br><b>Q45BW22FPQ</b><br><b>Q45BW22FPQ1</b> | Range varies by sensing mode and fiber optics used | 3-wire 2 m (6.5')<br>3-Pin Mini-style QD<br>4-Pin Micro-style QD | 90 to 250V ac  | SPST Solid-state Relay |   |              |

NOTES:

- i) 9 m (30') cables are available by adding suffix "W/30" to the model number of any cabled sensor (e.g., **Q45BW22FP W/30**)
- ii) A model with a QD connector requires a mating cable; see page 10.

## Q45BW22 Series Specifications

|                                    |   |
|------------------------------------|---|
| <b>Supply Voltage and Current</b>  | 90 to 250V ac (50 - 60 Hz). Average current 20 mA. Peak current 500 mA at 120C ac, 750 mA at 250V ac  |
| <b>Supply Protection Circuitry</b> | Protected against transient voltages.   |
| <b>Output Configuration</b>        | Short circuit/overload protected FET solid-state relay  |
| <b>Output Rating</b>               | <b>Continuous current:</b> 300 mA max. to 50° C (derate to 200 mA at 70°C, 5 mA/°C)<br><b>Inrush current:</b> 3A max. for 100 milliseconds, 5A max. for 1 millisecond<br><b>Off-state leakage current:</b> <100 microamps<br><b>Saturation voltage:</b> <3V at 200 mA   |
| <b>Output Protection Circuitry</b> | Manually-resettable output latch-out trips in the event of an output overload or short circuit condition. The green Power LED flashes to indicate the latch-out. To reset the output, remove power to the sensor and load for 5 seconds, then restore power.  |
| <b>Output Response Time</b>        | <b>Opposed mode:</b> 2 milliseconds ON, 1 millisecond OFF<br><b>All other sensing modes:</b> 2 milliseconds ON/OFF<br>(NOTE: 100 millisecond delay on power-up. Output is non-conducting during this time.)   |
| <b>Repeatability</b>               | <b>Opposed mode:</b> 0.25 milliseconds<br><b>All other sensing modes:</b> 0.5 milliseconds<br>Response time and repeatability specifications are independent of signal strength.  |
| <b>Adjustments</b>                 | <b>Beneath sensor's transparent cover:</b> Light/Dark Operate select switch; and multi-turn Sensitivity control (allows precise sensitivity setting – turn clockwise to increase gain). Optional logic and logic/display modules have adjustable timing functions (see page 10).  |
| <b>Indicators</b>                  | Indicator LEDs are clearly visible beneath a raised transparent Lexan® dome on top of the sensor.<br><b>Power (green) LED</b> lights whenever 90 to 250V ac power is applied, and flashes to indicate output overload or output short circuit<br><b>Signal (red) AID™ System LED</b> lights whenever the sensor sees its modulated light source, and pulses at a rate proportional to the strength of the received light signal<br><b>Load (yellow) LED</b> lights whenever the output relay is energized<br><b>Optional 7-element LED</b> signal strength display module |
| <b>Construction</b>                | Molded reinforced thermoplastic polyester housing, o-ring-sealed transparent Lexan® cover, molded acrylic lenses, and stainless steel hardware. Q45s are designed to withstand 1200 psi washdown. The base of cabled models has a 1/2" NPS integral internal conduit thread.  |
| <b>Environmental Rating</b>        | NEMA 6P, IEC IP67   |
| <b>Connections</b>                 | PVC-jacketed 2 m (6.5') or 9 m (30') cables, or 3-pin Mini-style ("Q" suffix models) or 4-pin Micro-style ("Q1" suffix models) quick-disconnect (QD) fittings are available. QD cables are ordered separately. See page 10.   |
| <b>Operating Conditions</b>        | <b>Temperature:</b> -40° to +70° C (-40° to +158°F)<br><b>Maximum relative humidity:</b> 90% at 50°C (non-condensing)   |
| <b>Application Notes</b>           | Optional output timing modules are available. See page 10 for more information.   |
| <b>Certifications</b>              |      |

Lexan® is a registered trademark of General Electric Co.

# Q45BW22 Series

## Q45BW22 Series Dimensions

Opposed, Retro, and Diffuse Sensing Modes  
(model suffix E, R, D, DL, DX, LP & LV)

### Cabled

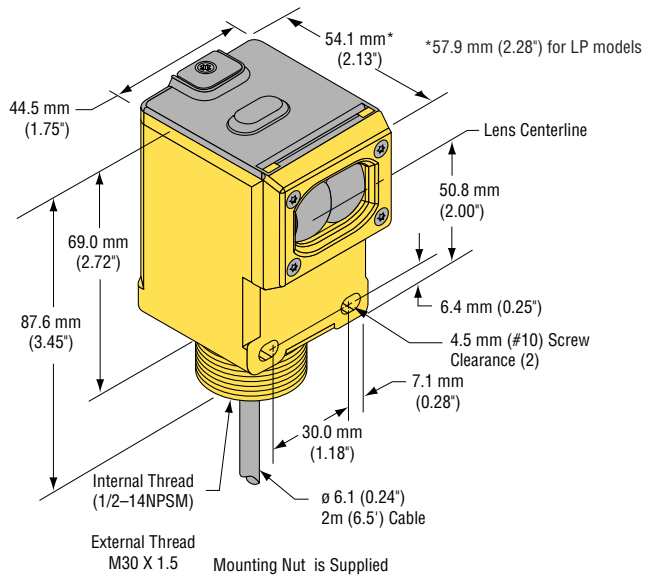

### Mini-style Quick-disconnect

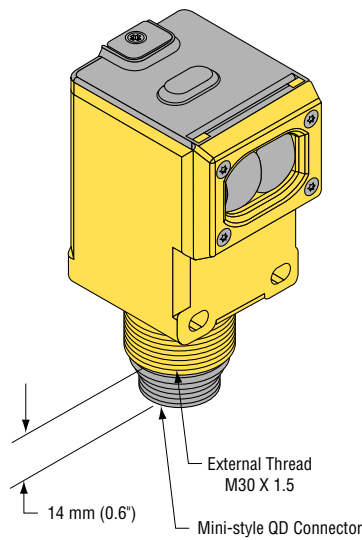

### Micro-style Quick-disconnect

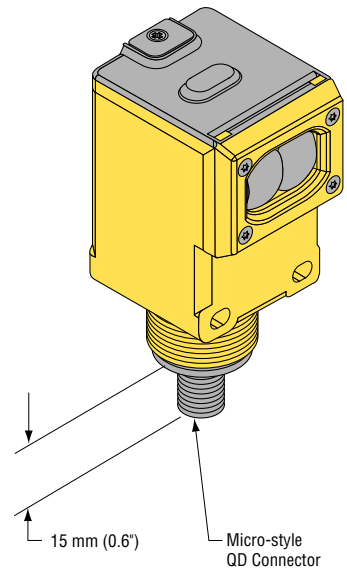

### Convergent Sensing Mode (model suffix CV & CV4)

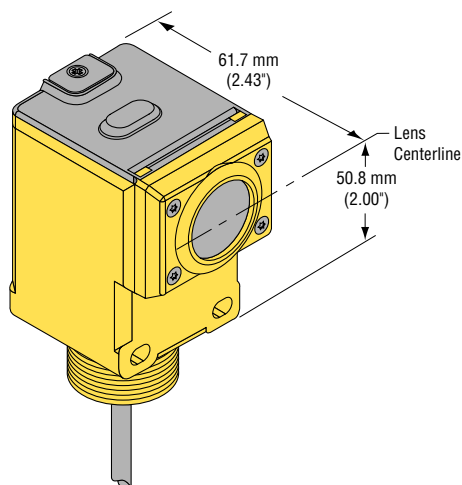

### Glass Fiber Optic (model suffix F and FV)

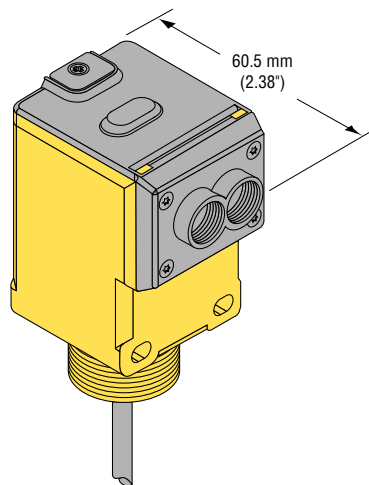

### Plastic Fiber Optic (model suffix FP)

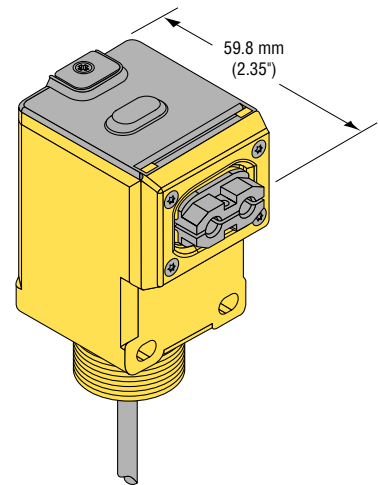

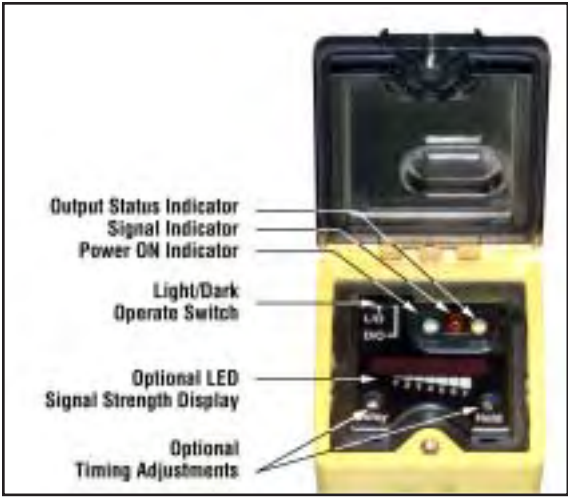

Figure 1. Indicators and controls on the Q45BW22 Series Sensors

## Q45BW22 Series Indicators and Controls

Status indicator LEDs for Power, Signal and Output are clearly visible beneath a raised dome in the sensor's transparent o-ring-sealed Lexan® cover. The Power indicator lights whenever power is applied to the sensor. The Signal LED lights whenever the sensor sees its modulated light source, and pulses at a rate proportional to the strength of the received light signal; this is the AID™ Alignment Indicating Device\*. The Output indicator lights whenever the sensor's output relay is energized. This indicator is especially useful when a timing logic module is used and Signal and Output conditions are not concurrent.

Also located beneath the sensor's o-ring-sealed cover are controls for light/dark operate selection and Sensitivity adjustment.

\* US patent no. 4356393

## Q45BW22 Series Hookups

### Q45BW22 Sensors with Attached Cable

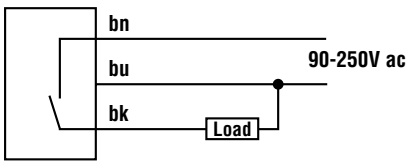

### Q45BW22 Sensors with Quick-Disconnect 3-Pin Mini-Style (model suffix Q)

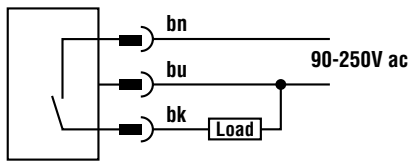

### Q45BW22 Sensors with Quick-Disconnect 4-Pin Micro-Style (model suffix Q1)

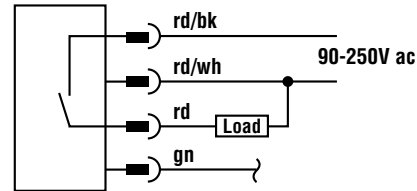

### Q452E Emitter with Attached Cable



### Q452E Emitter with Quick-Disconnect 3-Pin Mini-Style (model suffix Q)

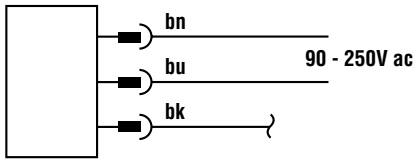

### Q452E Emitter with Quick-Disconnect 4-Pin Micro-Style (model suffix Q1)

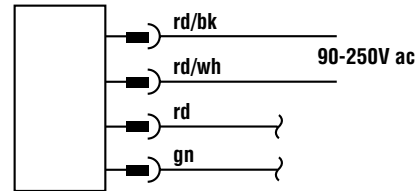

## Quick Disconnect (QD) Option

AC Q45BW22 Series sensors are sold with either a 2 m (6.5') or a 9 m (30') PVC-covered unterminated cable, or with a 3-pin Mini-style or 4-pin Micro-style QD cable fitting.

AC 3-pin Mini-style QD sensors are identified by the letter "Q" in their model number suffix and 4-pin Micro-style are identified by "Q1". Mating cables for QD Q45BW22 sensors are specified on page 10.

# Q45BW22 Series

## Accessories

### Quick-Disconnect Cables

**Cable:** PVC jacket, polyurethane connector body; nylon coupling nut (Mini), chrome-plated brass coupling nut (Micro)  
**Conductors:** 18 AWG (Mini), 22 or 20 AWG (Micro) high-flex stranded, PVC insulation, gold plated contacts  
**Temperature:** -40° to +80°C (-40° to +176°F)

| Style   | Model   | Length                               | Dimensions | Pin-Out (Female View) |
|---|---|--------------------------------------|------------|-----------------------|
| 3-Pin<br>Mini-style<br>Female<br>Pin-out<br>Straight  | <b>MBCC-306</b><br><b>MBCC-312</b><br><b>MBCC-330</b> | 2 m (6.5')<br>4 m (12')<br>9 m (30') |            |                       |
| 4-Pin<br>Micro-style<br>Female<br>Pin-out<br>Straight | <b>MQAC-406</b><br><b>MQAC-415</b><br><b>MQAC-430</b> | 2 m (6.5')<br>5 m (15')<br>9 m (30') |            |                       |

### Retroreflective Targets

Banner offers a wide selection of high-quality retroreflective targets. See the Accessories section of your current Banner Photoelectric Sensors catalog for complete information.

NOTE: Polarized sensors require corner cube type retroreflective targets only. Non-polarized sensors may use any retroreflective target.

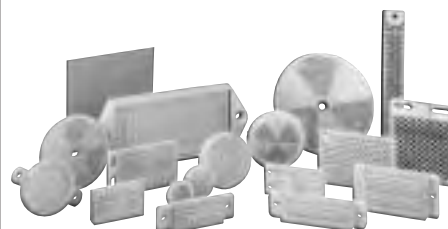

### Output Timing Logic and Signal Strength Display Modules

Q45 sensors easily accept the addition of output timing logic and signal strength display functions. Display modules have a seven-element display which gives a more precise indication of excess gain than does the AID™ system LED that is standard on Q45 sensors. The modules listed below may be used with all Q45VR2 sensors. See the data sheet packed with the module for more information.

| Model   | Logic and/or Display Function  |  |
|---|--|--|
| <b>45LM58</b><br><b>45LM58D</b><br><b>45LMD</b> | Programmable output timing logic<br>Programmable output timing logic plus signal strength display<br>Signal strength display only (no timing function) |  |

| Mounting Brackets   |             |            |
|---|-------------|------------|
| Model   | Description | Dimensions |
| <p><b>SMB30C</b></p> <ul style="list-style-type: none"> <li>• 30 mm split clamp, black PBT bracket</li> <li>• Stainless steel mounting hardware included</li> </ul>   |             |            |
| <p><b>SMB30MM</b></p> <ul style="list-style-type: none"> <li>• 30 mm, 11-gauge, stainless steel bracket with curved mounting slots for versatility and orientation</li> <li>• Clearance for M6 (1/4") hardware</li> </ul> |             |            |
| <p><b>SMB30SC</b></p> <ul style="list-style-type: none"> <li>• 30 mm swivel, black PBT bracket</li> <li>• Stainless steel mounting hardware included</li> </ul>   |             |            |