

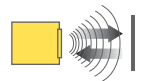

# U-GAGE™ Analog Q45U Long-Range Ultrasonic Sensors

*Piezoelectric Proximity Mode Sensors with Push-button  
Programming of Sensing Window Limits*

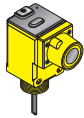

Ultrasonic

## Features

- Ultrasonic proximity detection from 0.25 to 3.0 m (9.8" to 118")
- Push button TEACH-mode programming of sensing window limits
- Digital filtering for exceptional immunity to electrical and acoustic "noise"
- Selectable 0 to 10V dc voltage sourcing or 4 to 20mA current sourcing analog outputs
- Selectable output slope: positive or negative with increasing target distance
- Wide operating temperature range of -25° to +70°C; all models include temperature compensation
- Rugged design for use in demanding sensing environments; rated IEC IP67, NEMA 6P
- Choose models with integral 2 m (6.5') or 9 meter (30') cable, or with Mini-style or Euro-style quick-disconnect fitting
- Input for remote TEACH-mode programming of window limits

## Analog Q45U Series Proximity Mode

| Models         | Temperature Compensation | Range                           | Cable *                | Supply Voltage | Output Type                                           | Response Time                                            |
|----------------|--------------------------|---------------------------------|------------------------|----------------|-------------------------------------------------------|----------------------------------------------------------|
| Q45ULIU64BCR   | Yes                      | 250 mm - 3.0 m<br>(9.8" - 118") | 2 m (6.5')             | 15-24V dc      | Selectable<br>0-10V dc<br>or<br>4 - 20 mA<br>sourcing | Adjustable from<br>80 milliseconds<br>to<br>2.56 seconds |
| Q45ULIU64BCRQ  |                          |                                 | 5-Pin<br>Mini-style QD |                |                                                       |                                                          |
| Q45ULIU64BCRQ6 |                          |                                 | 5-Pin<br>Euro-style QD |                |                                                       |                                                          |

\* NOTES:

- 9 m (30') cables are available by adding suffix "W/30" to the model number of the cabled sensor (e.g., **Q45ULIU64BCR W/30**).
- A model with a QD connector requires an optional mating cable, see page 8.

### Temperature Compensation:

All models listed above feature temperature compensation. An increase in air temperature shifts both sensing window limits closer to the sensor. Conversely, a decrease in air temperature shifts both limits further away from the sensor. The shift is approximately 3.5% of the limit distance for a 20°C change in temperature.

Temperature compensated models maintain the position of both sensing window limits to within 1% of each limit distance over the 0° to +50°C range, and to within 2.5% over the full operating range of from -25° to +70°C.

# U-GAGE™ Analog Q45U Long-Range Ultrasonic Sensors

## Near and Far Sensing Limit Settings:

The Q45U features a single push button for programming of sensing window near and far limits (Figure 1). See the programming procedure on page 4.

## Status Indicators:

Status indicator LEDs are visible through the transparent, o-ring sealed acrylic top cover. Indicator function in the **RUN** mode is, as follows:

- The green LED is on steadily whenever power is applied to the sensor, and flashes to indicate a current output fault.
- The red LED lights when an echo is received, and flashes at a rate that is proportional to echo strength.
- The yellow LED lights whenever the target is within the operating window limits.

The 5-segment moving dot LED indicator displays the relative position of the target within the programmed sensing window. The #1 LED flashes when the target is closer than the near limit. The #5 LED flashes when the target is beyond the far limit.

## Output Response Settings:

**IMPORTANT:** Remove power before making any internal adjustments.

Using the two slots shown in Figure 1, a small flat-blade screwdriver may be used to lift up and remove the black inner cover to expose the 4-position DIP switch (Figure 2).

Those switches are used to program the following functions: output slope, output mode, loss of echo, and min./max. output value default (see Figure 2).

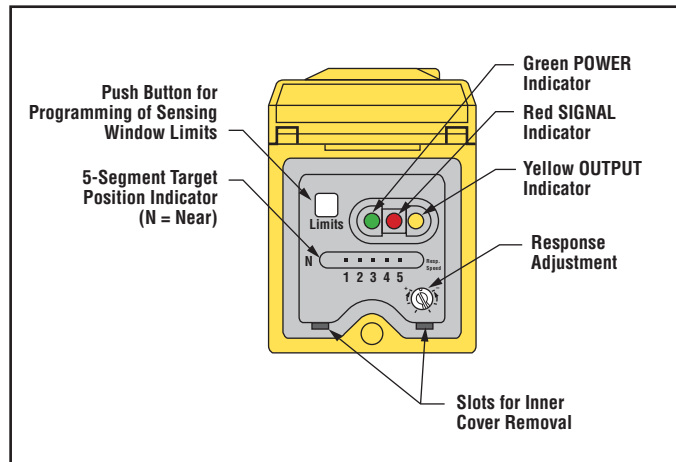

Figure 1. Analog Q45U Features

| Switch | Function            | Settings                                                                                               |
|--------|---------------------|--------------------------------------------------------------------------------------------------------|
| 1      | <b>Output Slope</b> | On = Output value <i>increases</i> with distance<br>Off* = Output value <i>decreases</i> with distance |
| 2      | <b>Output Mode</b>  | On = Current output enabled<br>Off* = Voltage output enabled                                           |
| 3      | <b>Loss of Echo</b> | On = Min - Max Mode<br>Off* = Hold Mode                                                                |
| 4      | <b>Min - Max</b>    | On* = Default to maximum output value<br>Off = Default to minimum output value                         |

Figure 2. Analog Q45U Programming Switches

# U-GAGE™ Analog Q45U Long-Range Ultrasonic Sensors

## Explanation of Programmable Output Functions:

### Switch 1: Output Slope Select

- On = Direct = Output value (voltage or current) increases with increasing distance of the target from the sensor
- Off\* = Inverse = Output value decreases with increasing distance of the target from the sensor

### Switch 2: Output Mode Select

- On = The 4 to 20 mA current output (white wire) is enabled
- Off\* = The 0 to 10V dc voltage output (black wire) is enabled

This switch configures the D/A driver to use either the current output or the voltage output driver. **This output function can only be set with the power to the sensor turned off.**

### Switch 3: Loss of Echo Mode Select

- On = Min - Max Mode
- Off\* = Hold Mode

This switch determines the output response to the loss of echo. The “Hold Mode” (Switch 3 Off\*) maintains the output at the value which was present at the time of echo loss. The “Min - Max Mode” (Switch 3 On) drives the output to either the minimum value (0V or 4mA or the maximum value (10V or 20mA) when the echo is lost. Minimum or maximum value is selected by Switch 4.

### Switch 4: Min - Max Default

- On\* = Default to maximum output value at loss of echo
- Off = Default to minimum output value at loss of echo

Switch 4 selects the output response to loss of echo when “Min - Max Mode” is selected by Switch 3 (see above).

### Response Speed Adjustment

The speed of the output response is set using the single-turn potentiometer (see Figures 1 and 4). There are six values for response speed, which relate directly to the number of sensing cycles over which the output value is averaged. The response value is set by aligning the slot of the potentiometer with one of the marked positions. The positions are identified in Figure 4.

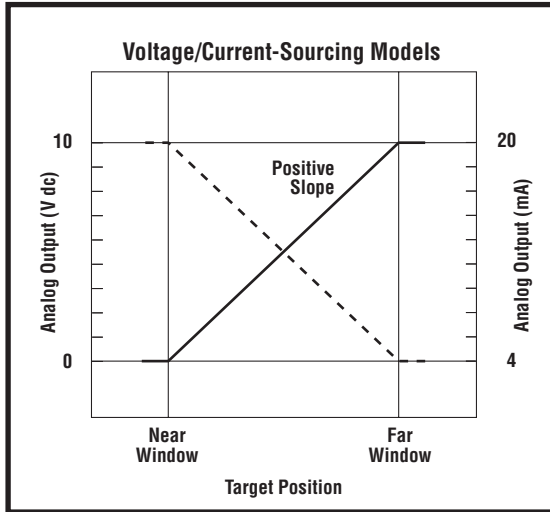

Figure 3. Output as a function of target position

| Response Speed Settings |                              |
|-------------------------|------------------------------|
| Position                | Response Speed               |
| 1                       | 80 milliseconds (2 cycles)   |
| 2                       | 160 milliseconds (4 cycles)  |
| 3                       | 320 milliseconds (8 cycles)  |
| 4                       | 640 milliseconds (16 cycles) |
| 5                       | 1.28 seconds (32 cycles)     |
| 6                       | 2.56 seconds (64 cycles)     |

**NOTE:** This example shows the potentiometer set at position number 4. There are no numbers on the actual product label.

Figure 4. Response Adjustment Positions

# U-GAGE™ Analog Q45U Long-Range Ultrasonic Sensors

## Window Limit Programming

The “Limits” push button, located under the transparent top cover, is used to program the near and the far limits. The near limit may be set as close as 250 mm (9.8") and the far limit may be set as far as 3.0 m (118") from the transducer face. Minimum window width is 25 mm (1"). Whenever possible, use the actual target to be sensed when setting the window limits. The following procedure begins with the sensor in RUN mode.

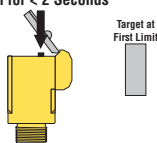
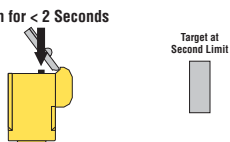
| Push Button                                                                                                                                                     | Indicator Status                                                                                                                                                                                                                                                                                                                                                                                                                                            |
|-----------------------------------------------------------------------------------------------------------------------------------------------------------------|-------------------------------------------------------------------------------------------------------------------------------------------------------------------------------------------------------------------------------------------------------------------------------------------------------------------------------------------------------------------------------------------------------------------------------------------------------------|
| <p><b>Step 1</b></p> <p><b>ACCESS LIMIT PROGRAMMING MODE</b></p> <p>Push and hold until green indicator turns off (approximately 2 seconds)</p>                 | <p>Push and Hold for <math>\geq 2</math> Seconds</p>  <p>Green: Goes off<br/>Yellow: Is on steadily to indicate ready for teaching first limit<br/>Red: Flashes to indicate strength of echo or is off if no target is present</p>                                                                                                                                         |
| <p><b>Step 2</b></p> <p><b>SET FIRST LIMIT (Near or Far)</b></p> <p>Place the target at the first limit and press the push button for less than 2 seconds</p>   | <p>Push for <math>&lt; 2</math> Seconds</p>  <p>Green: Remains off<br/>Yellow: Flashes at 2 Hz to indicate ready for teaching second limit<br/>Red: Comes on steadily for a moment, then resumes flashing to indicate strength of echo</p>                                                                                                                                 |
| <p><b>Step 3</b></p> <p><b>SET SECOND LIMIT (Far or Near)</b></p> <p>Place the target at the second limit and press the push button for less than 2 seconds</p> | <p>Push for <math>&lt; 2</math> Seconds</p>  <p>Green: Remains off, then comes on steadily (returns to <b>RUN</b> mode)<br/>Yellow: On steadily for a moment, then is either on or off to indicate output state (returns to <b>RUN</b> mode)<br/>Red: Comes on steadily for a moment, then resumes flashing to indicate strength of echo (returns to <b>RUN</b> mode)</p> |

### Notes regarding window limit programming:

- 1) Either the near or far limit may be programmed, first.
- 2) There is a 2-minute time-out for programming of the first limit. The sensor will return to RUN mode with the previously programmed limits. There is no time-out between programming of the first and second limit.
- 3) The programming sequence may be cancelled at any time by pressing and holding the push button for  $\geq 2$  seconds. The sensor returns to RUN mode with the previously programmed limits.
- 4) During limit programming, the 5-segment moving dot indicator displays the relative target position between 0 and 4.0 meters (the maximum recommended far limit position is 3.0 meters).
- 5) If the target is positioned between 3.0 and 4.0 meters, the 5th segment of the moving dot indicator flashes to indicate that a valid echo is received, but the target is beyond the recommended 3.0 meter maximum far limit.
- 6) If a limit is rejected during either programming step, the sensor will revert to the first limit programming step (Step 2 in programming chart). This will be indicated by Green - off, Red - flashing to indicate signal strength, and Yellow - on steady.
- 7) If both limits are accepted, the sensor will return to RUN mode, which is indicated by the Green LED coming on steady.
- 8) If the target is held at the same position for programming of both limits, the sensor will establish a 50 mm-wide sensing window, centered on the target position.

# U-GAGE™ Analog Q45U Long-Range Ultrasonic Sensors

| Analog Q45U Series Specifications     |                                                                                                                                                                                                                                                                                                                                                                                                                                                                                                           |
|---------------------------------------|-----------------------------------------------------------------------------------------------------------------------------------------------------------------------------------------------------------------------------------------------------------------------------------------------------------------------------------------------------------------------------------------------------------------------------------------------------------------------------------------------------------|
| <b>Proximity Mode Range</b>           | Near limit: 250 mm (9.8") min<br>Far limit: 3.0 m (118")<br>NOTE: The far limit may be extended as far as 3.9 m for good acoustical targets (hard surfaces with area > 100 cm <sup>2</sup> )                                                                                                                                                                                                                                                                                                              |
| <b>Supply Voltage and Current</b>     | 15 to 24V dc (10% maximum ripple) at 100mA, exclusive of load                                                                                                                                                                                                                                                                                                                                                                                                                                             |
| <b>Supply Protection Circuitry</b>    | Protected against reverse polarity and transient voltages                                                                                                                                                                                                                                                                                                                                                                                                                                                 |
| <b>Output Configuration</b>           | One voltage sourcing and one current sourcing; one or the other output is enabled by internal programming switch #2. Output function may be programmed by a 4-position DIP switch located on top of the sensor, beneath the transparent o-ring sealed acrylic cover (see page 3 for complete information)                                                                                                                                                                                                 |
| <b>Output Rating</b>                  | <b>Voltage sourcing:</b> 0 to 10V dc, 10mA maximum<br><b>Current sourcing:</b> 4 to 20mA, 1 to 500 ohm impedance                                                                                                                                                                                                                                                                                                                                                                                          |
| <b>Output Protection Circuitry</b>    | Both outputs are protected against continuous overload and short circuit                                                                                                                                                                                                                                                                                                                                                                                                                                  |
| <b>Performance Specifications</b>     | <b>Sensing Repeatability:</b> ±0.1% of the measured distance (±0.50 mm minimum)<br><b>Sensing Resolution:</b> 0.50 mm (0.02 in)<br><b>Analog Output Resolutions:</b> 2mV, 3µA                                                                                                                                                                                                                                                                                                                             |
| <b>Indicators</b>                     | Three status LEDs:<br><b>Green ON steady</b> = power to sensor is ON<br><b>Green flashing</b> = current output fault detected (indicates that the 4-20mA current path to ground has been opened)<br><b>Yellow ON steady</b> = target is sensed within the window limits (Yellow LED also indicates programming status during setup mode)<br><b>Red flashing</b> = indicates relative strength of received echo<br>5-segment moving dot LED indicates the position of the target within the sensing window |
| <b>Construction</b>                   | Molded PBT thermoplastic polyester housing, o-ring sealed transparent acrylic top cover, and stainless steel hardware. Q45U sensors are designed to withstand 1200 psi washdown. The base of cabled models has a 1/2"-14NPS internal conduit thread                                                                                                                                                                                                                                                       |
| <b>Environmental Rating</b>           | Leakproof design is rated IEC IP67; NEMA 6P                                                                                                                                                                                                                                                                                                                                                                                                                                                               |
| <b>Connections</b>                    | 2 m (6.5') or 9 m (30') attached cable, or 5-pin Mini-style or 5-pin Euro-style quick-disconnect fitting                                                                                                                                                                                                                                                                                                                                                                                                  |
| <b>Operating Temperature</b>          | <b>Temperature:</b> -25° to +70°C (-13° to +158°F)<br><b>Maximum relative humidity:</b> 100%                                                                                                                                                                                                                                                                                                                                                                                                              |
| <b>Vibration and Mechanical Shock</b> | All models meet Mil. Std. 202F requirements. Method 201A (Vibration: 10 to 60Hz max., double amplitude 0.06-inch, maximum acceleration 10G). Method 213B conditions H & I (Shock: 75G with unit operating; 100G for non-operation) Also meets IEC 947-5-2 requirements: 30G, 11 ms duration, half sine wave                                                                                                                                                                                               |
| <b>Application Notes</b>              | <b>Minimum target size:</b> 50 mm x 50 mm aluminum plate at 3.0 m (118")                                                                                                                                                                                                                                                                                                                                                                                                                                  |

# U-GAGE™ Analog Q45U Long-Range Ultrasonic Sensors

## Remote Window Limit Programming

The yellow wire of the Analog Q45U may be connected to a switch or process controller for remote programming of the sensing window limits. The programming procedure is the same as for the push button (see page 4).

A remote programming input is generated when +5 to 24V dc is applied to the yellow wire. The timing diagrams, below, define the required input pulses.

### Notes regarding remote window limit programming:

- 1) The push button is disabled during remote limit programming. (The remote programming input is disabled during push button programming.)
- 2) Also see the notes regarding window limit programming on page 4.

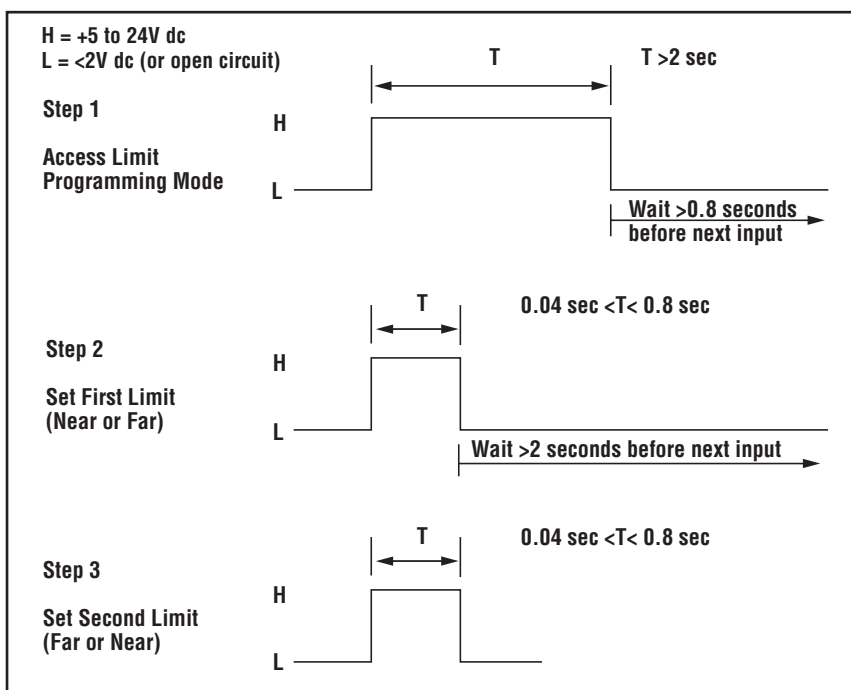
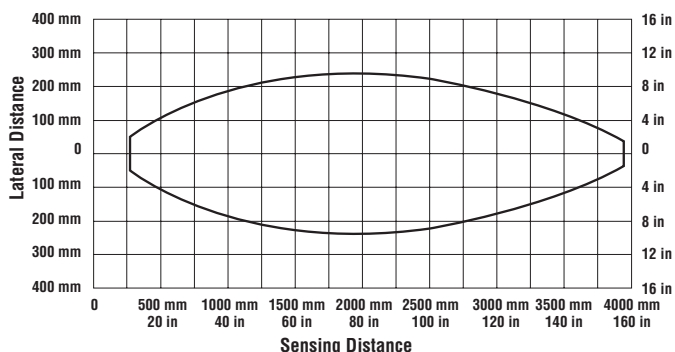

Figure 5. Remote window limit programming

## Analog Q45U Response Curves

### Analog Q45U Effective Beam with 100 mm x 100 mm Plate Target (Typical)



### Analog Q45U Effective Beam with 2.5 cm Dia. Rod Target (Typical)

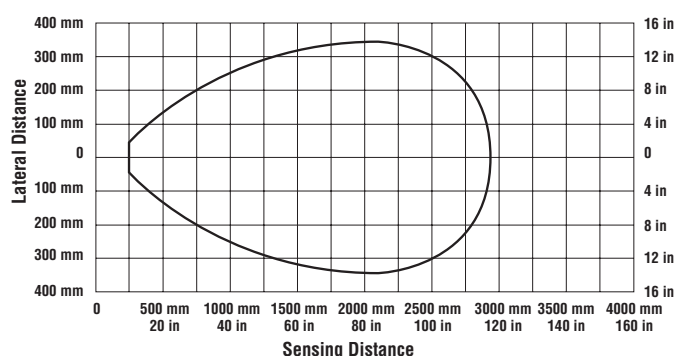

# U-GAGE™ Analog Q45U Long-Range Ultrasonic Sensors

## Analog Q45U Series Hookups

**Q45U Sensor with Attached Cable**

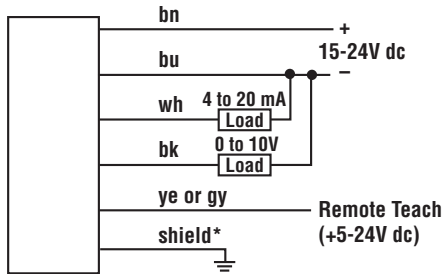

**Q45U Sensor with 5-Pin Mini-Style QD ("Q" model suffix)**

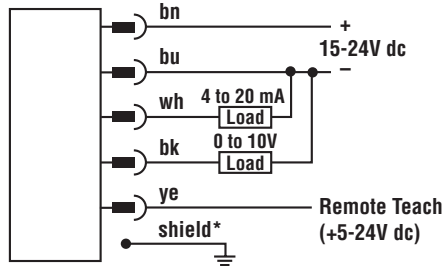

**Q45U Sensor with 5-Pin Euro-Style QD ("Q6" model suffix)**

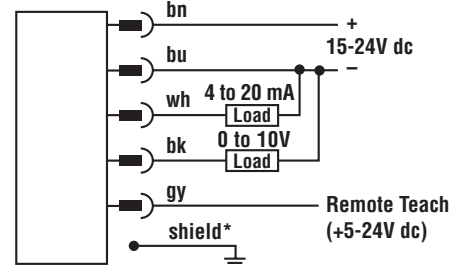

\*It is recommended that the shield wire be connected to earth ground or dc common.

**5-Pin Mini-Style Pin-out (Cable Connector Shown)**

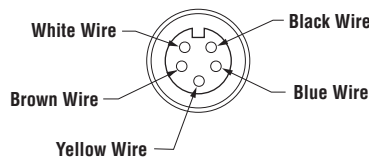

**5-Pin Euro-Style Pin-out (Cable Connector Shown)**

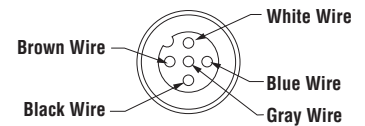

## Analog Q45U Series Dimensions

**Q45U Sensor with Attached Cable**

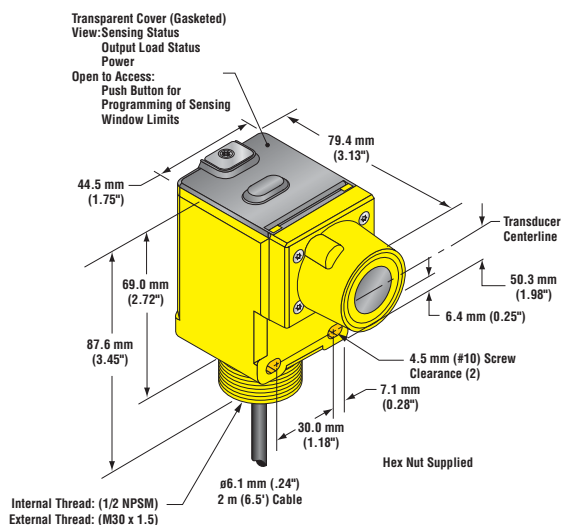

**Q45U Sensor with 5-Pin Mini-Style QD ("Q" model suffix)**

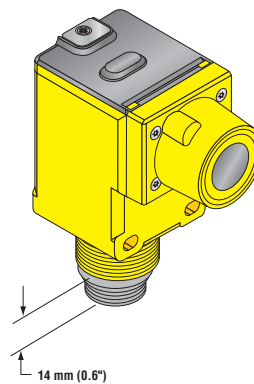

**Q45U Sensor with 5-Pin Euro-Style QD ("Q6" model suffix)**

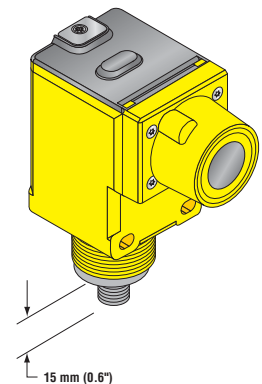

# U-GAGE™ Analog Q45U Long-Range Ultrasonic Sensors

## Quick-Disconnect (QD) Cables

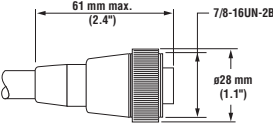
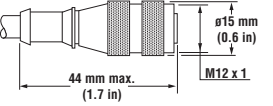
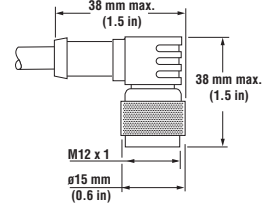
| Description                                       | Model                                                             | Length                                              | Connector                                                                         |
|---------------------------------------------------|-------------------------------------------------------------------|-----------------------------------------------------|-----------------------------------------------------------------------------------|
| 5-Pin<br>Mini-style<br>with shield                | <b>MBCC2-506</b><br><b>MBCC2-512</b><br><b>MBCC2-530</b>          | 2 meters (6.5')<br>4 meters (12')<br>9 meters (30') |  |
| 5-Pin<br>Euro-style<br>Straight<br>with shield    | <b>MQDEC2-506</b><br><b>MQDEC2-515</b><br><b>MQDEC2-530</b>       | 2 meters (6.5')<br>5 meters (15')<br>9 meters (30') |  |
| 5-Pin<br>Euro-style<br>Right-angle<br>with shield | <b>MQDEC2-506RA</b><br><b>MQDEC2-515RA</b><br><b>MQDEC2-530RA</b> | 2 meters (6.5')<br>5 meters (15')<br>9 meters (30') |  |

**WARRANTY:** Banner Engineering Corp. warrants its products to be free from defects for one year. Banner Engineering Corp. will repair or replace, free of charge, any product of its manufacture found to be defective at the time it is returned to the factory during the warranty period. This warranty does not cover damage or liability for the improper application of Banner products. This warranty is in lieu of any other warranty either expressed or implied.



**WARNING . . .**  
**Not to be used for personnel protection**

**Never use these products as sensing devices for personnel protection. Doing so could lead to serious injury or death.**

These sensors do NOT include the self-checking redundant circuitry necessary to allow their use in personnel safety applications. A sensor failure or malfunction can cause either an energized or de-energized sensor output condition. Consult your current Banner Safety Products catalog for safety products which meet OSHA, ANSI, and IEC standards for personnel protection.

## Mounting Brackets

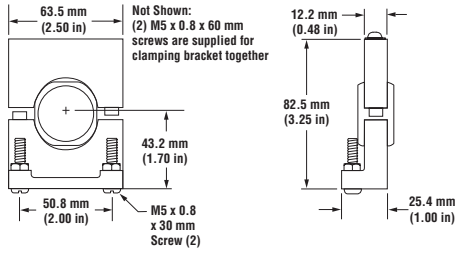
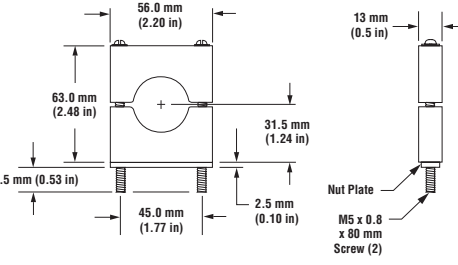
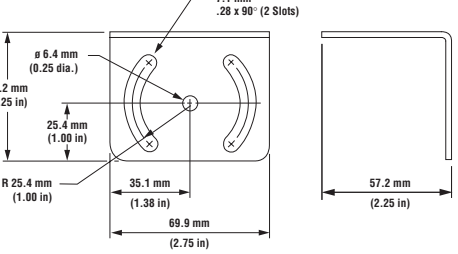
| Model          | Description                                                                                                                                                                                     | Dimensions                                                                          |
|----------------|-------------------------------------------------------------------------------------------------------------------------------------------------------------------------------------------------|-------------------------------------------------------------------------------------|
| <b>SMB30S</b>  | <ul style="list-style-type: none"> <li>30 mm swivel, black PBT bracket</li> <li>Stainless steel mounting hardware included</li> </ul>                                                           |  |
| <b>SMB30C</b>  | <ul style="list-style-type: none"> <li>30 mm split clamp, black PBT bracket</li> <li>Stainless steel mounting hardware included</li> </ul>                                                      |  |
| <b>SMB30MM</b> | <ul style="list-style-type: none"> <li>30 mm, 11-gauge, stainless steel bracket with curved mounting slots for versatility and orientation</li> <li>Clearance for M6 (1/4") hardware</li> </ul> |  |

**BANNER®**  
more sensors, more solutions



Figure 1. Remove the output card using a small screwdriver to dislodge it from its connector.



Figure 2. Switch settings

### Features

- Transfer the programmed sensing window limit settings from any Q45U sensor to the master window limit programming card
- Card stores window limit settings in non-volatile memory
- Transfer window limit settings stored on a card back to the Q45U sensor at any time
- Transfer window limit settings stored on one card to any Q45U which has the same sensing range as the sensor used to store the limit settings (i. e. - either long range or short range)

### Description

The Q45UML plugs into any Q45U ultrasonic proximity mode sensor in place of the sensor's output card. It can download the sensing window limit settings from the sensor it is plugged into. Those sensing limit settings are stored on the card in non-volatile memory, until new sensing limit settings are downloaded to it.

The sensor limit settings residing on the Q45UML card may be transferred to any Q45U sensor, as long as that sensor has the same range (long or short range) as the sensor used to store the limit settings on the Q45UML.

### Storing Window Limit Settings on the Q45UML Card

Use the following procedure to copy sensing window limit settings from a Q45U sensor to the Q45UML master window limit programming card:

- 1) Remove power from the Q45U sensor.
- 2) Remove the output card from the Q45U sensor (Figure 1). Use a small screwdriver, or similar tool, to dislodge the output card from its connector. Then, slide the card out of the sensor.
- 3) Turn switch #1 on the Q45UML card to "off" (see Figure 2). Note that only switch #1 is used. Switches #2, 3, and 4 have no function.
- 4) Slide the Q45UML card into the sensor in place of the sensor output card (Figure 3). Push it firmly into place.
- 5) Apply power to the sensor. The window limits are copied to the Q45UML card when power is applied to the sensor. The center three segments of the 5-segment LED indicator on the Q45UML will flash simultaneously to verify that the limit settings have been copied to the card.
- 6) Remove power from the Q45U sensor.
- 7) Remove the Q45UML card in the same manner used to remove the output card in step 2 (Figure 1).
- 8) Turn switch #1 on the Q45UML to "on" (Figure 2) to lock the window limit settings into memory.
- 9) Slide the output card back into the Q45U sensor, and push firmly into place.



**Figure 3.** Slide the Q45UML card into the sensor and push it firmly into place.

## Transferring Window Limit Settings from the Q45UML to a Sensor

Use the following procedure to copy sensing window limit settings stored on a Q45UML card to a Q45U sensor:

- 1) Remove power from the Q45U sensor.
- 2) Remove the output card from the Q45U sensor (Figure 1). Use a small screwdriver, or similar tool, to dislodge the output card from its connector. Then, slide the card out of the sensor.
- 3) Check to be certain that Switch #1 on the Q45UML card is set to "on" (see Figure 2).
- 4) Slide the Q45UML card into the sensor in place of the sensor output card (Figure 3). Push it firmly into place.
- 5) Apply power to the sensor. The window limits are copied from the Q45UML card when power is applied to the sensor. The outermost two segments of the 5-segment LED indicator on the Q45UML will flash simultaneously to verify that the limit settings have been copied to the sensor.
- 6) Remove power from the Q45U sensor.
- 7) Remove the Q45UML card in the same manner used to remove the output card in step 2 (Figure 1).
- 8) Slide the output card back into the Q45U sensor, and push firmly into place.



# U-GAGE™ Q45U Long-Range Ultrasonic Sensors

*Piezoelectric Proximity Mode Sensors with Push Button Programming of Sensing Window Limits – Bipolar Discrete Outputs*



- Analog models also available
- Models with other ranges also available

## Features

- Ultrasonic proximity detection from 0.25 to 3.0 m (9.8" to 118")
- Push button TEACH mode programming of sensing window limits
- Digital filtering for exceptional immunity to electrical and acoustic “noise”
- 12 to 24V dc operation
- Bipolar outputs: one NPN (sinking) and one PNP (sourcing)
- ON/OFF presence detection or HIGH/LOW level control are switch-selectable
- Wide operating temperature range of -25° to +70°C; models available with temperature compensation
- Rugged design for use in demanding sensing environments; rated IEC IP67, NEMA 6P
- Choose models with integral 2 m (6.5') or 9 m (30') cable, or with Mini-style or Euro-style quick-disconnect fitting
- External enable/disable feature for remote gating control

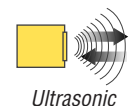
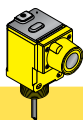

## Q45U Series Long-Range Proximity Mode Sensor Models

| Models       | Temperature Compensation* | Range                           | Cable**       | Supply Voltage | Output Type        | Response Time                                            |
|--------------|---------------------------|---------------------------------|---------------|----------------|--------------------|----------------------------------------------------------|
| Q45UBB63BC   | Yes                       | 250 mm - 3.0 m<br>(9.8" - 118") | 2 m (6.5')    | 12-24V dc      | Bipolar<br>NPN/PNP | Programmable for<br>40, 80, 320, or 1280<br>milliseconds |
| Q45UBB63BCQ  |                           |                                 | 5-Pin Mini QD |                |                    |                                                          |
| Q45UBB63BCQ6 |                           |                                 | 5-Pin Euro QD |                |                    |                                                          |

### \*Models with Temperature Compensation:

An increase in air temperature shifts both sensing window limits closer to the sensor. Conversely, a decrease in air temperature shifts both limits further away from the sensor. The shift is approximately 3.5% of the limit distance for a 20°C change in temperature.

Temperature compensated models maintain the position of both sensing window limits to within 1% of each limit distance over the range of from 0° to +50°C, and to within 2.5% over the full operating range of from -25° to +70°C.

### \*\*NOTES:

- 9 m (30') cables are available by adding suffix “W/30” to the model number of any cabled sensor (e.g., **Q45UBB63BC W/30**)
- A model with a QD connector requires an optional mating cable, see page 8.



### WARNING . . . Not To Be Used for Personnel Protection

**Never use these products as sensing devices for personnel protection. Doing so could lead to serious injury or death.**

These sensors do NOT include the self-checking redundant circuitry necessary to allow their use in personnel safety applications. A sensor failure or malfunction can cause either an energized or de-energized sensor output condition. Consult your current Banner Safety Products catalog for safety products which meet OSHA, ANSI and IEC standards for personnel protection.

# Q45U Long-Range Ultrasonic Sensors with Bipolar Discrete Outputs

## Near and Far Sensing Limit Settings:

The Q45U features a single push button for programming of sensing window near and far limits (Figure 1). See the programming procedure on page 4.

## Status Indicators:

Status indicator LEDs are visible through the transparent, o-ring sealed Lexan® top cover. Indicator function in the RUN mode is, as follows:

- The green LED is on steadily whenever power is applied to the sensor, and flashes to indicate an overloaded output.
- The red LED lights when an echo is received, and flashes at a rate that is proportional to echo strength.
- The yellow LED lights whenever the outputs are conducting.

The 5-segment moving dot LED indicator displays the relative position of the target within the programmed sensing window. The #1 LED flashes when the target is closer than the near limit. The #5 LED flashes when the target is beyond the far limit.

## Output Response Settings:

**IMPORTANT:** Remove power before making any internal adjustments.

Using the two slots shown in Figure 1, a small flat-blade screwdriver may be used to lift up and remove the black inner cover to expose the 4-position DIP switch (Figure 2). Those switches are used to program the following functions:

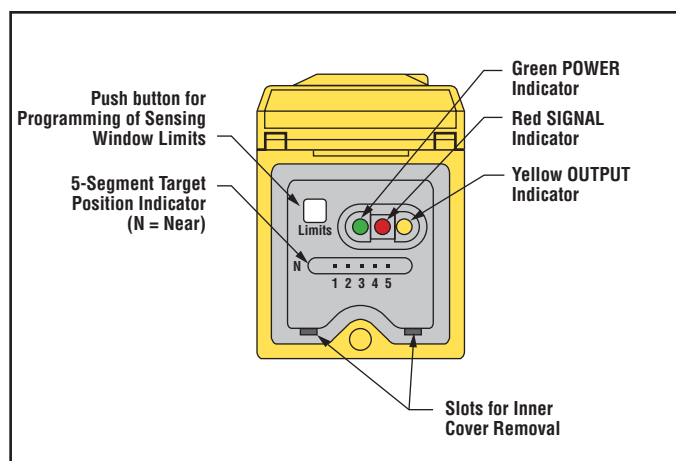

Figure 1. Q45U Features

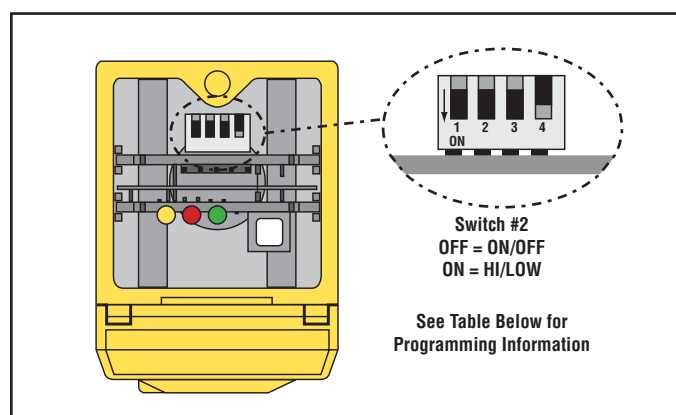

Figure 2. Q45U Programming Switches

| Switch | Function                                                                                                                                                  |                 |                                                        |
|--------|-----------------------------------------------------------------------------------------------------------------------------------------------------------|-----------------|--------------------------------------------------------|
| 1      | <b>ON/OFF</b> Mode<br>Output: On = normally closed (output energizes when target is absent)<br>Off* = normally open (output energizes when target sensed) |                 | <b>HIGH/LOW</b> Mode<br>On = Pump Out<br>Off = Pump In |
| 2      | Mode: On = <b>HIGH/LOW</b> (fill level control, see description, on page 3)<br>Off* = <b>ON/OFF</b> (output follows sensing action)                       |                 |                                                        |
| 3 - 4  | <b>Response</b> (40 ms/cycle)                                                                                                                             | <b>Switch 3</b> | <b>Switch 4</b>                                        |
|        | 1 Cycle                                                                                                                                                   | Off             | Off                                                    |
|        | 2 Cycles                                                                                                                                                  | On              | Off                                                    |
|        | 8 Cycles*                                                                                                                                                 | Off             | On                                                     |
|        | 32 Cycles                                                                                                                                                 | On              | On                                                     |

\*Denotes factory settings.

**NOTE:** Response setting of 2 cycles, or higher, is recommended for optimum sonic and electrical noise immunity. Always use the slowest acceptable response speed for your application. Single cycle update is only recommended for short range (>1.0 m) applications looking for a stationary background target.

# Q45U Long-Range Ultrasonic Sensors with Bipolar Discrete Outputs

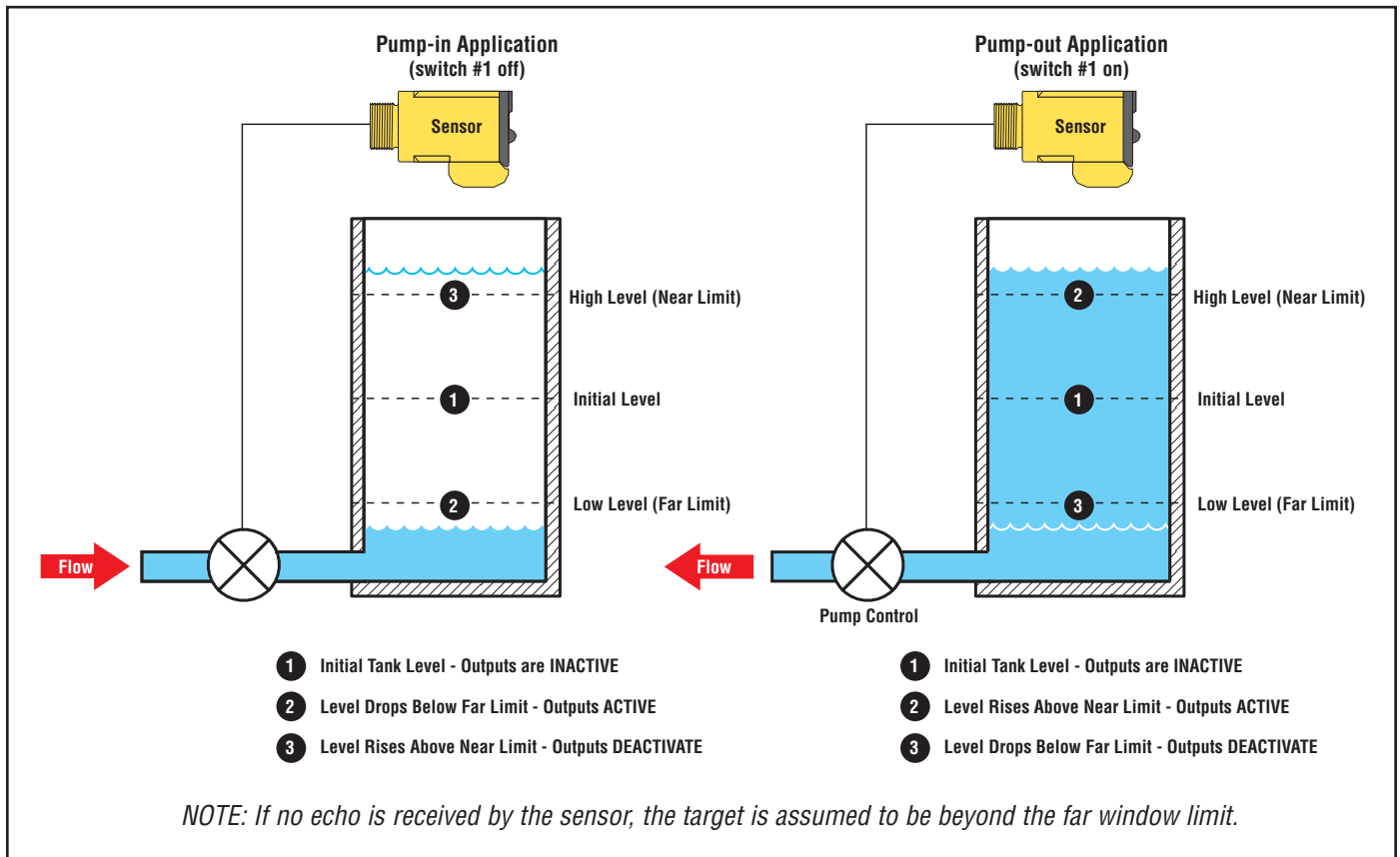



Figure 3. High/Low Level Control (switch #2 on)

The **HIGH/LOW** mode (switch #2 on) provides the switching logic required for fill-level, web tensioning control, and similar applications. In the HIGH/LOW mode, the output energizes when the target reaches the first sensing window limit, and stays energized until the target moves to the second limit. The output then de-energizes at the second limit and does not re-energize until the target moves, again, to the first limit. Figure 3 shows how pumping action might be controlled, directly, by the sensor in a fill-level application.

# Q45U Long-Range Ultrasonic Sensors with Bipolar Discrete Outputs

## Window Limit Programming

The "Limits" push button, located under the transparent top cover, is used to program the near and the far limits. The near limit may be set as close as 250 mm (9.8") and the far limit may be set as far as 3.0 m (118") from the transducer face. Minimum window width is 25 mm (1.0"). Whenever possible, use the actual target to be sensed when setting the window limits. The following procedure begins with the sensor in RUN mode.

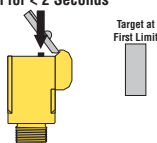
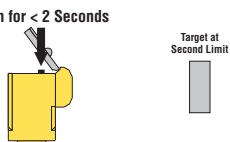
| Push Button                                                                                                                                                  | Indicator Status                                                                                                                       |                                                                                                                                                                                                                                                                                                                              |
|--------------------------------------------------------------------------------------------------------------------------------------------------------------|----------------------------------------------------------------------------------------------------------------------------------------|------------------------------------------------------------------------------------------------------------------------------------------------------------------------------------------------------------------------------------------------------------------------------------------------------------------------------|
| <p><b>Step 1</b></p> <p>Push and hold until green indicator turns off (approximately 2 seconds)</p>                                                          | <p>Push and Hold for <math>\geq 2</math> Seconds</p>  | <p>Green: Goes off<br/>Yellow: Is on steadily to indicate ready for teaching first limit<br/>Red: Flashes to indicate strength of echo or is off if no target is present</p>                                                                                                                                                 |
| <p><b>Step 2</b></p> <p><b>FIRST LIMIT</b> (Near or Far)<br/>Place the target at the first limit and press the push button for less than 2 seconds</p>       | <p>Push for <math>&lt; 2</math> Seconds</p>           | <p>Green: Remains off<br/>Yellow: Flashes at 2 Hz to indicate ready for teaching second limit<br/>Red: Comes on steadily for a moment, then resumes flashing to indicate strength of echo</p>                                                                                                                                |
| <p><b>Step 3</b></p> <p><b>SET SECOND LIMIT</b> (Far or Near)<br/>Place the target at the second limit and press the push button for less than 2 seconds</p> | <p>Push for <math>&lt; 2</math> Seconds</p>          | <p>Green: Remains off, then comes on steadily (returns to <b>RUN</b> mode)<br/>Yellow: On steadily for a moment, then is either on or off to indicate output state (returns to <b>RUN</b> mode)<br/>Red: Comes on steadily for a moment, then resumes flashing to indicate strength of echo (returns to <b>RUN</b> mode)</p> |

## Notes regarding window limit programming:

- 1) Either the near or far limit may be programmed, first.
- 2) There is a 2-minute timeout for programming of the first limit. The sensor will return to RUN mode with the previously programmed limits. There is no timeout between programming of the first and second limit.
- 3) The programming sequence may be cancelled at any time by pressing and holding the push button for  $\geq 2$  seconds. The sensor returns to RUN mode with the previously programmed limits.
- 4) During limit programming, the 5-segment moving dot indicator displays the relative target position between 0 and 4.0 m (the maximum recommended far limit position is 3.0 m).
- 5) If the target is positioned between 3.0 and 4.0 m, the 5th segment of the moving dot indicator flashes to indicate that a valid echo is received, but the target is beyond the recommended 3.0 meter maximum far limit.
- 6) If a limit is rejected during either programming step, the sensor will revert to the first limit programming step (Step 2 in programming chart). This will be indicated by Green - off, Red - flashing to indicate signal strength, and Yellow - on steadily.
- 7) If both limits are accepted, the sensor will return to RUN mode, which is indicated by the Green LED coming on steadily.
- 8) If the target is held at the same position for programming of both limits, the sensor will establish a 50 mm wide sensing window, centered on the target position.

# Q45U Long-Range Ultrasonic Sensors with Bipolar Discrete Outputs

## Q45U Series Long-Range Sensor Specifications

|                                       |                                                                                                                                                                                                                                                                                                                                                                                                                                                                                 |
|---------------------------------------|---------------------------------------------------------------------------------------------------------------------------------------------------------------------------------------------------------------------------------------------------------------------------------------------------------------------------------------------------------------------------------------------------------------------------------------------------------------------------------|
| <b>Proximity Mode Range</b>           | <p><b>Near limit:</b> 250 mm (9.8") min<br/> <b>Far limit:</b> 3.0 m (118")</p> <p>Note: The far limit may be extended as far as 3.9 m for good acoustical targets (hard surfaces with area &gt; 100 cm<sup>2</sup>)</p>                                                                                                                                                                                                                                                        |
| <b>Supply Voltage and Current</b>     | 12 to 24V dc (10% maximum ripple) at 100 mA, exclusive of load                                                                                                                                                                                                                                                                                                                                                                                                                  |
| <b>Supply Protection Circuitry</b>    | Protected against reverse polarity and transient voltages                                                                                                                                                                                                                                                                                                                                                                                                                       |
| <b>Output Configuration</b>           | <p>Bipolar: one current sourcing (PNP) and one current sinking (NPN) open-collector transistor; The following may be selected by a 4-position DIP switch located on top of the sensor, beneath a transparent o-ring sealed acrylic cover (see page 2):</p> <p>Switch 1: Output normally open/normally closed (pump in/pump out)<br/> Switch 2: High/Low level control mode or on/off presence sensing mode<br/> Switch 3 &amp; 4: Response speed selection (digital filter)</p> |
| <b>Output Rating</b>                  | <p>150 mA maximum (each)</p> <p><b>Off-state leakage current:</b> &lt; 25 microamp at 24V dc<br/> <b>On-state saturation voltage:</b> &lt; 1.5V at 10mA; &lt; 2.0V at 150 mA</p>                                                                                                                                                                                                                                                                                                |
| <b>Output Protection Circuitry</b>    | Protected against false pulse on power-up and continuous overload or short-circuit of outputs                                                                                                                                                                                                                                                                                                                                                                                   |
| <b>Performance Specifications</b>     | <p><b>Repeatability:</b> ±0.1% of measured distance (±0.50 mm min)<br/> <b>Minimum Window Width:</b> 25 mm (1.0")<br/> <b>Hysteresis:</b> 10 mm (0.4")</p>                                                                                                                                                                                                                                                                                                                      |
| <b>Indicators</b>                     | <p>Three status LEDs:</p> <p><b>Green ON steady</b> = power to sensor is ON<br/> <b>Green flashing</b> = output is overloaded<br/> <b>Yellow ON steady</b> = outputs are conducting (RUN mode)<br/> programming status (SETUP mode)<br/> <b>Red flashing</b> = indicates relative strength of received echo</p> <p>5-segment moving dot LED indicates the position of the target within the sensing window</p>                                                                  |
| <b>Construction</b>                   | Molded PBT thermoplastic polyester housing, o-ring sealed transparent acrylic top cover, and stainless steel hardware. Q45U sensors are designed to withstand 1200 psi washdown. The base of cabled models has a 1/2"-14NPS internal conduit thread                                                                                                                                                                                                                             |
| <b>Environmental Rating</b>           | Leakproof design is rated IEC IP67; NEMA 6P                                                                                                                                                                                                                                                                                                                                                                                                                                     |
| <b>Connections</b>                    | 2 m (6.5') or 9 m (30') attached cable, or 5-pin Mini-style or 5-pin Euro-style quick disconnect fitting                                                                                                                                                                                                                                                                                                                                                                        |
| <b>Operating Conditions</b>           | <p><b>Temperature:</b> -25° to +70°C (-13° to +158°F)<br/> <b>Maximum relative humidity:</b> 100%</p>                                                                                                                                                                                                                                                                                                                                                                           |
| <b>Vibration and Mechanical Shock</b> | All models meet Mil. Std. 202F requirements. Method 201A (Vibration: 10 to 60Hz max., double amplitude 0.06", maximum acceleration 10G). Method 213B conditions H & I (Shock: 75G with unit operating; 100G for non-operation) Also meets IEC 947-5-2 requirements: 30G, 11 ms duration, half sine wave.                                                                                                                                                                        |
| <b>Hysteresis</b>                     | <p><b>ON/OFF mode:</b> 10 mm<br/> <b>HIGH/LOW mode:</b> 0 mm</p>                                                                                                                                                                                                                                                                                                                                                                                                                |
| <b>Application Notes</b>              | <p><b>Minimum target size:</b> 50 mm x 50 mm aluminum plate at 3.0 m (118")</p> <p><b>Enable/Disable:</b> Connect yellow wire to +5 to 24V dc to enable sensor and 0 to +2V dc to disable sensor. When the sensor is disabled, the last output state is held until the sensor is re-enabled. The wire must be held to the appropriate voltage for at least 40 ms for the sensor to enable or disable.</p>                                                                       |

# Q45U Long-Range Ultrasonic Sensors with Bipolar Discrete Outputs

## Q45U Response Curves

**Q45U Effective Beam  
with 2.5 cm Rod Target (Typical)**

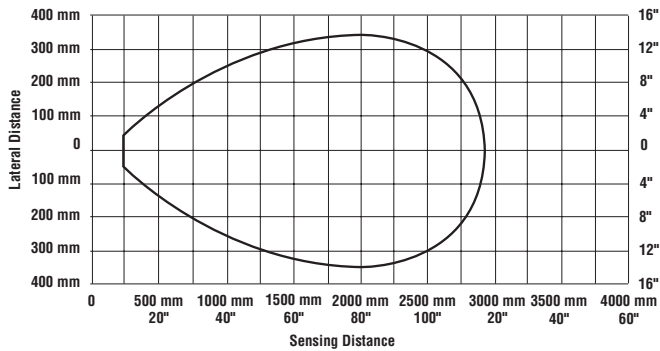

**Q45U Effective Beam  
with 100 mm x 100 mm Plate Target (Typical)**

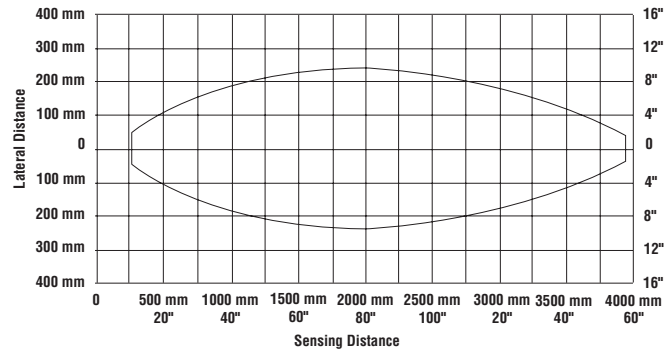

## Q45U Series Dimensions

**Q45U Sensor with Attached Cable**

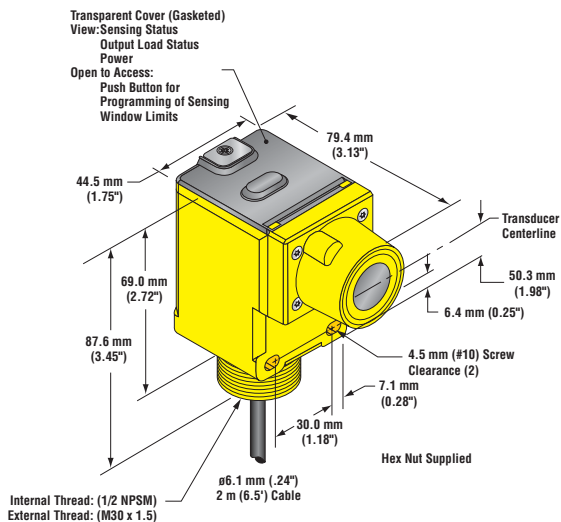

**Q45U Sensor  
with 5-Pin Mini-Style QD  
("Q" model suffix)**

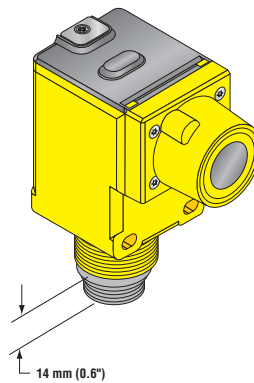

**Q45U Sensor  
with 5-Pin Euro-Style QD  
("Q6" model suffix)**

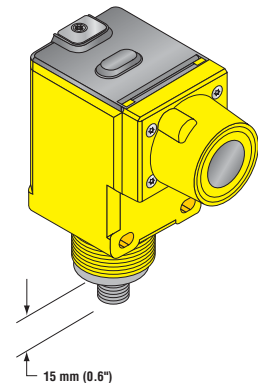

# Q45U Long-Range Ultrasonic Sensors with Bipolar Discrete Outputs

## Q45U Series Hookup Diagrams

Q45U Sensor with Attached Cable

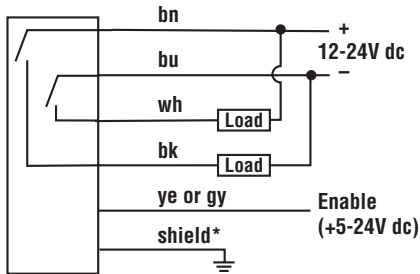

Q45U Sensor with 5-Pin Mini-Style QD ("Q" model suffix)

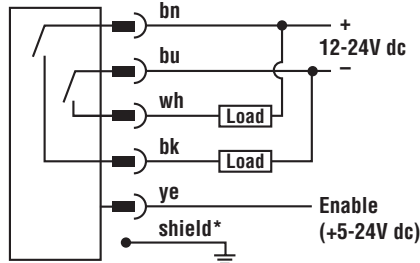

Q45U Sensor with 5-Pin Euro-Style QD ("Q6" model suffix)

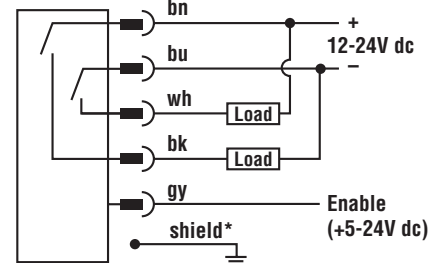

\*It is recommended that the shield wire be connected to earth ground or dc common.

## Quick-Disconnect (QD) Cables

| Style                                    | Model                                        | Length                               | Connector | Pin-out |
|------------------------------------------|----------------------------------------------|--------------------------------------|-----------|---------|
| 5-Pin Mini-style with Shield             | MBCC2-506<br>MBCC2-512<br>MBCC2-530          | 2 m (6.5')<br>4 m (12')<br>9 m (30') |           |         |
| 5-Pin Euro-style Straight with Shield    | MQDEC2-506<br>MQDEC2-515<br>MQDEC2-530       | 2 m (6.5')<br>5 m (15')<br>9 m (30') |           |         |
| 5-Pin Euro-style Right-angle with shield | MQDEC2-506RA<br>MQDEC2-515RA<br>MQDEC2-530RA | 2 m (6.5')<br>5 m (15')<br>9 m (30') |           |         |

# Q45U Long-Range Ultrasonic Sensors with Bipolar Discrete Outputs

| Mounting Brackets |                                                                                                                                                                                                     |               |                                                                                                                                           |
|-------------------|-----------------------------------------------------------------------------------------------------------------------------------------------------------------------------------------------------|---------------|-------------------------------------------------------------------------------------------------------------------------------------------|
| <b>SMB30C</b>     | <ul style="list-style-type: none"> <li>• 30 mm split clamp, black PBT bracket</li> <li>• Stainless steel mounting hardware included</li> </ul>                                                      | <b>SMB30S</b> | <ul style="list-style-type: none"> <li>• 30 mm swivel, black PBT bracket</li> <li>• Stainless steel mounting hardware included</li> </ul> |
|                   |                                                                                                                                                                                                     |               |                                                                                                                                           |
| <b>SMB30MM</b>    | <ul style="list-style-type: none"> <li>• 30 mm, 11-gauge, stainless steel bracket with curved mounting slots for versatility and orientation</li> <li>• Clearance for M6 (1/4") hardware</li> </ul> |               |                                                                                                                                           |
|                   |                                                                                                                                                                                                     |               |                                                                                                                                           |



**WARRANTY:** Banner Engineering Corp. warrants its products to be free from defects for one year. Banner Engineering Corp. will repair or replace, free of charge, any product of its manufacture found to be defective at the time it is returned to the factory during the warranty period. This warranty does not cover damage or liability for the improper application of Banner products. This warranty is in lieu of any other warranty either expressed or implied.

## U-GAGE™ Analog Q45U Ultrasonic Sensors

*Piezoelectric Analog Proximity Mode Sensors with Push-button or Remote Programming of Sensing Window Limits*



### Features

- Ultrasonic proximity detection from 100 to 1400 mm (4" to 55")
- Push-button TEACH-mode programming of sensing window limits
- Digital filtering for exceptional immunity to electrical and acoustic “noise”
- Selectable 0 to 10V dc voltage sourcing or 4 to 20 mA current sourcing analog outputs
- Selectable output slope: positive or negative with increasing target distance
- Wide operating temperature range of -25° to +70°C; all models include temperature compensation
- Rugged design for use in demanding sensing environments; rated IEC IP67, NEMA 6P
- Choose models with integral 2 m (6.5') or 9 m (30') cable, or with Mini-style or Euro-style quick-disconnect fitting
- Input for remote TEACH-mode programming of window limits

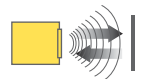
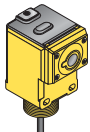

Ultrasonic

### Models

| Models         | Temperature Compensation | Range                        | Cable*                 | Supply Voltage | Output Type                                           | Response Time                                            |
|----------------|--------------------------|------------------------------|------------------------|----------------|-------------------------------------------------------|----------------------------------------------------------|
| Q45ULIU64ACR   | Yes                      | 100 mm - 1.4 m<br>(4" - 55") | 2 m (6.5')             | 15-24V dc      | Selectable<br>0-10V dc<br>or<br>4 - 20 mA<br>sourcing | Adjustable from<br>40 milliseconds<br>to<br>1.28 seconds |
| Q45ULIU64ACRQ  |                          |                              | 5-Pin<br>Mini-style QD |                |                                                       |                                                          |
| Q45ULIU64ACRQ6 |                          |                              | 5-Pin<br>Euro-style QD |                |                                                       |                                                          |

\* NOTES:

- 9 m (30') cables are available by adding suffix “W/30” to the model number of the cabled sensor (e.g., **Q45ULIU64ACR W/30**).
- A model with a QD connector requires an optional mating cable, see page 8.

#### Temperature Compensation:

All models listed above feature temperature compensation. An increase in air temperature shifts both sensing window limits closer to the sensor. Conversely, a decrease in air temperature shifts both limits further away from the sensor. The shift is approximately 3.5% of the limit distance for a 20°C change in temperature.

Temperature compensated models maintain the position of both sensing window limits to within 1% of each limit distance over the 0° to +50°C range, and to within 2.5% over the full operating range of from -25° to +70°C.

# U-GAGE™ Analog Q45U Ultrasonic Sensors

## Near and Far Sensing Limit Settings:

The Q45U features a single push button for programming of sensing window near and far limits (Figure 1). See the programming procedure on page 4.

## Status Indicators:

Status indicator LEDs are visible through the transparent, o-ring sealed acrylic top cover. Indicator function in the **RUN** mode is, as follows:

- The green LED is on steadily whenever power is applied to the sensor, and flashes to indicate a current output fault.
- The red LED lights when an echo is received, and flashes at a rate that is proportional to echo strength.
- The yellow LED lights whenever the target is within the operating window limits.

The 5-segment moving dot LED indicator displays the relative position of the target within the programmed sensing window. The #1 LED flashes when the target is closer than the near limit. The #5 LED flashes when the target is beyond the far limit.

## Output Response Settings:

**IMPORTANT:** Remove power before making any internal adjustments.

Using the two slots shown in Figure 1, a small flat-blade screwdriver may be used to lift up and remove the black inner cover to expose the 4-position DIP switch (Figure 2).

Those switches are used to program the following functions: output slope, output mode, loss of echo, and min./max. output value default (see Figure 2).

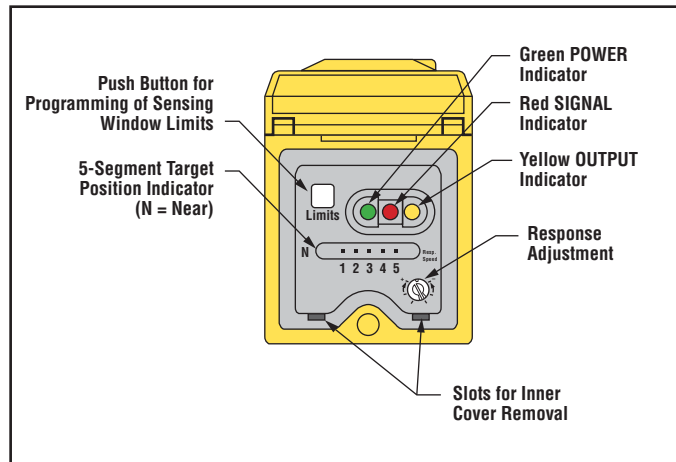

Figure 1. Analog Q45U Features

| Switch | Function            | Settings                                                                                               |
|--------|---------------------|--------------------------------------------------------------------------------------------------------|
| 1      | <b>Output Slope</b> | On = Output value <i>increases</i> with distance<br>Off* = Output value <i>decreases</i> with distance |
| 2      | <b>Output Mode</b>  | On = Current output enabled<br>Off* = Voltage output enabled                                           |
| 3      | <b>Loss of Echo</b> | On = Min - Max Mode<br>Off* = Hold Mode                                                                |
| 4      | <b>Min - Max</b>    | On* = Default to maximum output value<br>Off = Default to minimum output value                         |

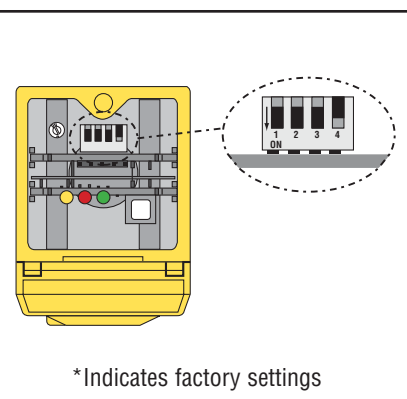

Figure 2. Analog Q45U Programming Switches

# U-GAGE™ Analog Q45U Ultrasonic Sensors

## Explanation of Programmable Output Functions:

### Switch 1: Output Slope Select

- On = Direct = Output value (voltage or current) increases with increasing distance of the target from the sensor
- Off\* = Inverse = Output value decreases with increasing distance of the target from the sensor

### Switch 2: Output Mode Select

- On = The 4 to 20 mA current output (white wire) is enabled
- Off\* = The 0 to 10V dc voltage output (black wire) is enabled

This switch configures the D/A driver to use either the current output or the voltage output driver. **This output function can only be set with the power to the sensor turned off.**

### Switch 3: Loss of Echo Mode Select

- On = Min - Max Mode
- Off\* = Hold Mode

This switch determines the output response to the loss of echo. The “Hold Mode” (Switch 3 Off\*) maintains the output at the value which was present at the time of echo loss. The “Min - Max Mode” (Switch 3 On) drives the output to either the minimum value (0V or 4mA or the maximum value (10V or 20mA) when the echo is lost. Minimum or maximum value is selected by Switch 4.

### Switch 4: Min - Max Default

- On\* = Default to maximum output value at loss of echo
- Off = Default to minimum output value at loss of echo

Switch 4 selects the output response to loss of echo when “Min - Max Mode” is selected by Switch 3 (see above).

### Response Speed Adjustment

The speed of the output response is set using the single-turn potentiometer (see Figures 1 and 4). There are six values for response speed, which relate directly to the number of sensing cycles over which the output value is averaged. The response value is set by aligning the slot of the potentiometer with one of the marked positions. The positions are identified in Figure 4.

\* Factory setting

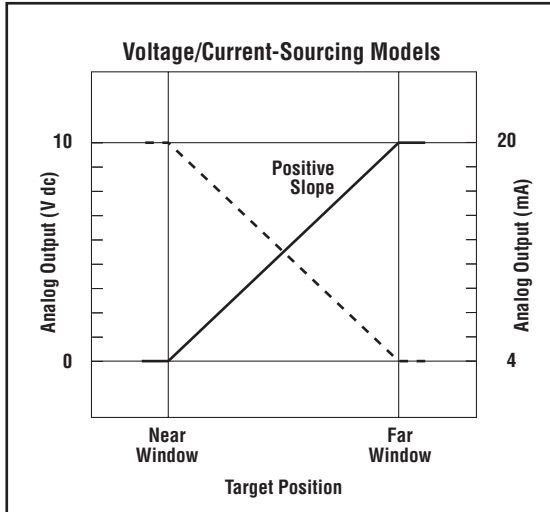

Figure 3. Output as a function of target position

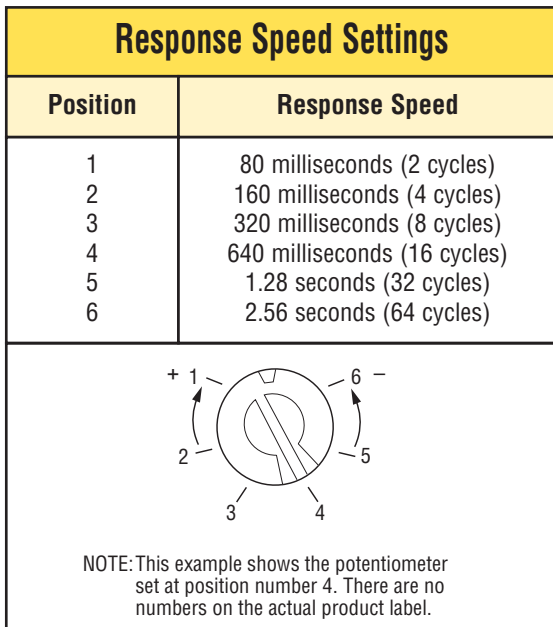

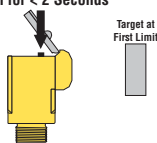
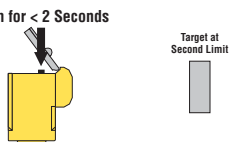

Figure 4. Response adjustment positions

# U-GAGE™ Analog Q45U Ultrasonic Sensors

## Window Limit Programming

The “Limits” push button, located under the transparent top cover, is used to program the near and the far limits. The near limit may be set as close as 100 mm (4") and the far limit may be set as far as 1400 mm (55") from the transducer face. Minimum window width is 10 mm (0.4"). Whenever possible, use the actual target to be sensed when setting the window limits. The following procedure begins with the sensor in RUN mode.

| Push Button                                                                                                                                                     | Indicator Status                                                                                                                                                                                                                                                                                                                                                                                                                                            |
|-----------------------------------------------------------------------------------------------------------------------------------------------------------------|-------------------------------------------------------------------------------------------------------------------------------------------------------------------------------------------------------------------------------------------------------------------------------------------------------------------------------------------------------------------------------------------------------------------------------------------------------------|
| <p><b>Step 1</b></p> <p><b>ACCESS LIMIT PROGRAMMING MODE</b></p> <p>Push and hold until green indicator turns off (approximately 2 seconds)</p>                 | <p>Push and Hold for <math>\geq 2</math> Seconds</p>  <p>Green: Goes off<br/>Yellow: Is on steadily to indicate ready for teaching first limit<br/>Red: Flashes to indicate strength of echo or is off if no target is present</p>                                                                                                                                         |
| <p><b>Step 2</b></p> <p><b>SET FIRST LIMIT (Near or Far)</b></p> <p>Place the target at the first limit and press the push button for less than 2 seconds</p>   | <p>Push for <math>&lt; 2</math> Seconds</p>  <p>Green: Remains off<br/>Yellow: Flashes at 2 Hz to indicate ready for teaching second limit<br/>Red: Comes on steadily for a moment, then resumes flashing to indicate strength of echo</p>                                                                                                                                 |
| <p><b>Step 3</b></p> <p><b>SET SECOND LIMIT (Far or Near)</b></p> <p>Place the target at the second limit and press the push button for less than 2 seconds</p> | <p>Push for <math>&lt; 2</math> Seconds</p>  <p>Green: Remains off, then comes on steadily (returns to <b>RUN</b> mode)<br/>Yellow: On steadily for a moment, then is either on or off to indicate output state (returns to <b>RUN</b> mode)<br/>Red: Comes on steadily for a moment, then resumes flashing to indicate strength of echo (returns to <b>RUN</b> mode)</p> |

### Notes regarding window limit programming:

- 1) Either the near or far limit may be programmed, first.
- 2) There is a 2-minute time-out for programming of the first limit. The sensor will return to RUN mode with the previously programmed limits. There is no time-out between programming of the first and second limit.
- 3) The programming sequence may be cancelled at any time by pressing and holding the push button for  $\geq 2$  seconds. The sensor returns to RUN mode with the previously programmed limits.
- 4) During limit programming, the 5-segment moving dot indicator displays the relative target position between 0 and 1500 mm (the maximum recommended far limit position is 1400 mm).
- 5) If the target is positioned between 1400 and 1500 mm, the 5th segment of the moving dot indicator flashes to indicate that a valid echo is received, but the target is beyond the recommended 1400 mm maximum far limit.
- 6) If a limit is rejected during either programming step, the sensor will revert to the first limit programming step (Step 2 in programming chart). This will be indicated by Green - off, Red - flashing to indicate signal strength, and Yellow - on steady.
- 7) If both limits are accepted, the sensor will return to RUN mode, which is indicated by the Green LED coming on steady.
- 8) If the target is held at the same position for programming of both limits, the sensor will establish a 10 mm-wide sensing window, centered on the target position.

# U-GAGE™ Analog Q45U Ultrasonic Sensors

| Analog Q45U Series Specifications     |                                                                                                                                                                                                                                                                                                                                                                                                                                                                                                            |
|---------------------------------------|------------------------------------------------------------------------------------------------------------------------------------------------------------------------------------------------------------------------------------------------------------------------------------------------------------------------------------------------------------------------------------------------------------------------------------------------------------------------------------------------------------|
| <b>Proximity Mode Range</b>           | <b>Near limit:</b> 100 mm (4.0") min<br><b>Far limit:</b> 1.4 m (55") max                                                                                                                                                                                                                                                                                                                                                                                                                                  |
| <b>Supply Voltage and Current</b>     | 15 to 24V dc (10% maximum ripple) at 100 mA, exclusive of load                                                                                                                                                                                                                                                                                                                                                                                                                                             |
| <b>Supply Protection Circuitry</b>    | Protected against reverse polarity and transient voltages                                                                                                                                                                                                                                                                                                                                                                                                                                                  |
| <b>Output Configuration</b>           | One voltage sourcing and one current sourcing; one or the other output is enabled by internal programming switch #2. Output function may be programmed by a 4-position DIP switch located on top of the sensor, beneath the transparent o-ring sealed acrylic cover (see page 3 for complete information)                                                                                                                                                                                                  |
| <b>Output Rating</b>                  | Voltage sourcing: 0 to 10V dc, 10mA maximum<br>Current sourcing: 4 to 20mA, 1 to 500 ohm impedance                                                                                                                                                                                                                                                                                                                                                                                                         |
| <b>Output Protection Circuitry</b>    | Both outputs are protected against continuous overload and short circuit                                                                                                                                                                                                                                                                                                                                                                                                                                   |
| <b>Performance Specifications</b>     | <b>Sensing Repeatability:</b> $\pm 0.1\%$ of the measured distance ( $\pm 0.25$ mm minimum)<br><b>Sensing Resolution:</b> 0.25 mm (0.01 in)<br><b>Analog Output Resolutions:</b> 2mV, 3 $\mu$ A                                                                                                                                                                                                                                                                                                            |
| <b>Indicators</b>                     | Three status LEDs:<br><b>Green ON steady</b> = power to sensor is ON<br><b>Green flashing</b> = current output fault detected (indicates that the 4-20 mA current path to ground has been opened)<br><b>Yellow ON steady</b> = target is sensed within the window limits (Yellow LED also indicates programming status during setup mode)<br><b>Red flashing</b> = indicates relative strength of received echo<br>5-segment moving dot LED indicates the position of the target within the sensing window |
| <b>Construction</b>                   | Molded PBT thermoplastic polyester housing, o-ring sealed transparent acrylic top cover, and stainless steel hardware. Q45U sensors are designed to withstand 1200 psi washdown. The base of cabled models has a 1/2"-14NPS internal conduit thread                                                                                                                                                                                                                                                        |
| <b>Environmental Rating</b>           | Leakproof design is rated IEC IP67; NEMA 6P                                                                                                                                                                                                                                                                                                                                                                                                                                                                |
| <b>Connections</b>                    | 2 m (6.5') or 9 m (30') attached cable, or 5-pin Mini-style or 5-pin Euro-style quick-disconnect fitting                                                                                                                                                                                                                                                                                                                                                                                                   |
| <b>Operating Temperature</b>          | <b>Temperature:</b> -25° to +70°C (-13° to +158°F)<br><b>Maximum relative humidity:</b> 100%                                                                                                                                                                                                                                                                                                                                                                                                               |
| <b>Vibration and Mechanical Shock</b> | All models meet Mil. Std. 202F requirements. Method 201A (Vibration: 10 to 60Hz max., double amplitude 0.06-inch, maximum acceleration 10G). Method 213B conditions H & I (Shock: 75G with unit operating; 100G for non-operation) Also meets IEC 947-5-2 requirements: 30G, 11 ms duration, half sine wave                                                                                                                                                                                                |
| <b>Application Notes</b>              | <b>Minimum target size:</b> 10 mm x 10 mm aluminum plate at 500 mm (20")<br>35 mm x 35 mm aluminum plate at 1.4 m (55")                                                                                                                                                                                                                                                                                                                                                                                    |

# U-GAGE™ Analog Q45U Ultrasonic Sensors

## Remote Window Limit Programming

The yellow wire of the Analog Q45U may be connected to a switch or process controller for remote programming of the sensing window limits. The programming procedure is the same as for the push button (see page 4).

A remote programming input is generated when +5 to 24V dc is applied to the yellow wire. The timing diagrams, below, define the required input pulses.

### Notes regarding remote window limit programming:

- 1) The push button is disabled during remote limit programming. (The remote programming input is disabled during push button programming.)
- 2) Also see the notes regarding window limit programming on page 4.

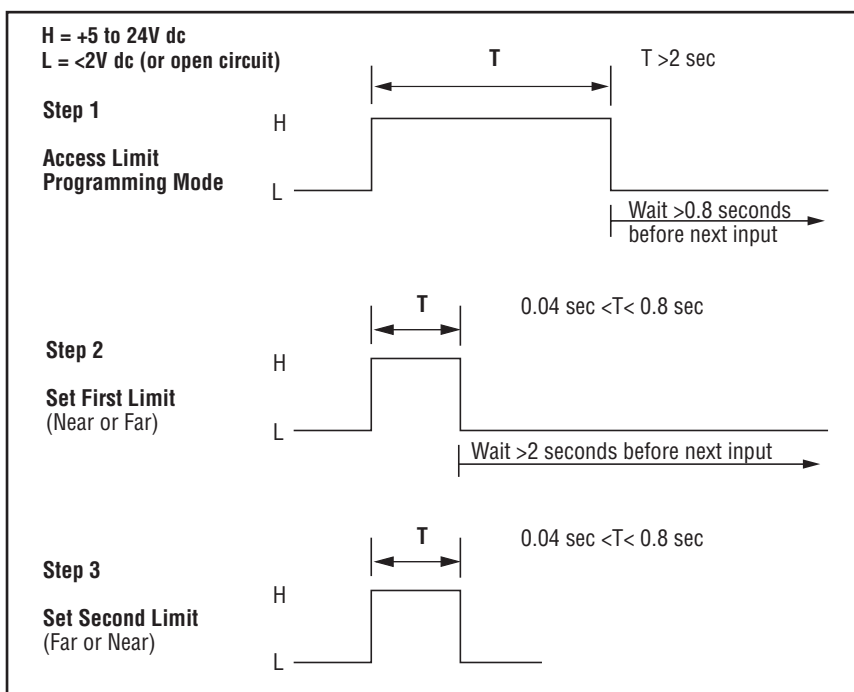
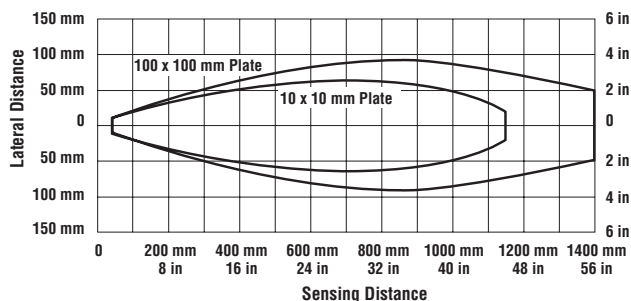

Figure 5. Remote window limit programming

## Analog Q45U Response Curves

### Analog Q45U Effective Beam with Plate Target (Typical)



### Analog Q45U Effective Beam with Rod Target (Typical)

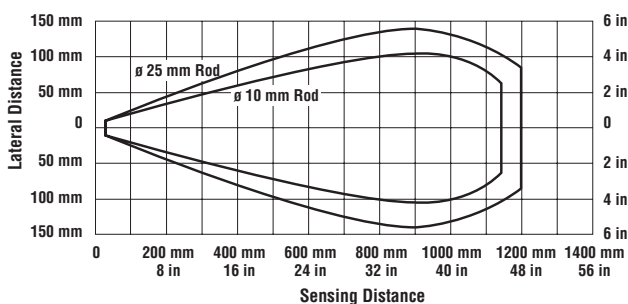

# U-GAGE™ Analog Q45U Ultrasonic Sensors

## Analog Q45U Series Hookups

**Q45U Sensor with Attached Cable**

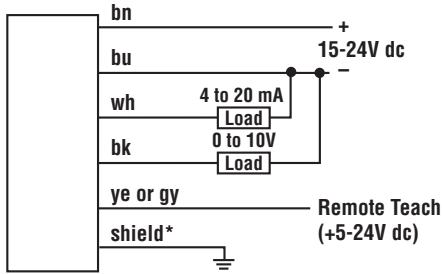

**Q45U Sensor with 5-Pin Mini-Style QD ("Q" model Suffix)**

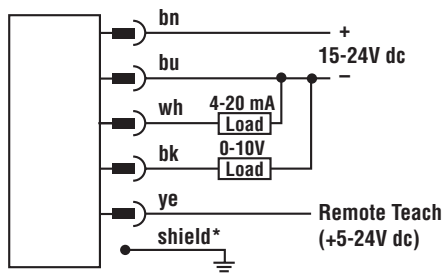

**Q45U Sensor with 5-Pin Euro-Style QD ("Q6" model Suffix)**

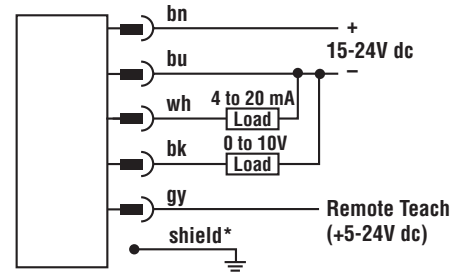

\*It is recommended that the shield wire be connected to earth ground or dc common.

**5-Pin Mini-Style Pin-out (Cable Connector Shown)**

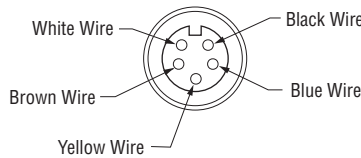

**5-Pin Euro-Style Pin-out (Cable Connector Shown)**

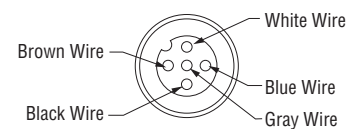

## Q45U Series Dimensions

**Q45U Sensor with Attached Cable**

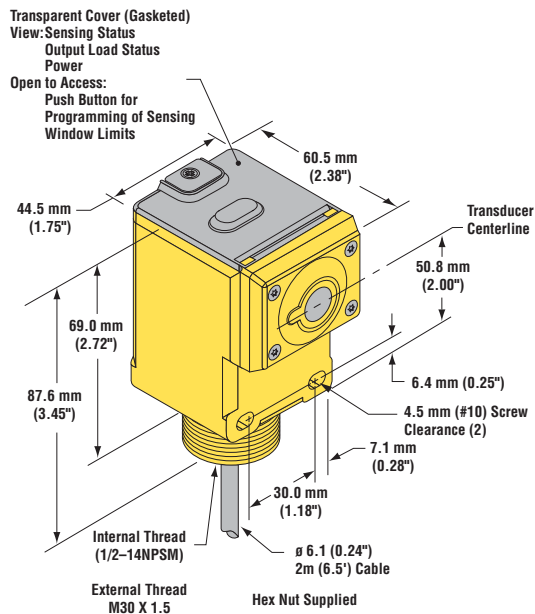

**Q45U Sensor with 5-Pin Mini-Style QD ("Q" model Suffix)**

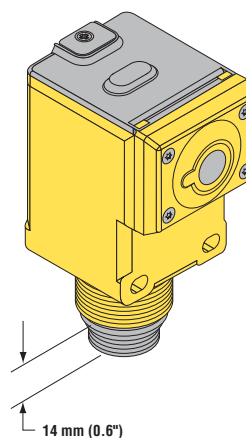

**Q45U Sensor with 5-Pin Euro-Style QD ("Q6" model Suffix)**

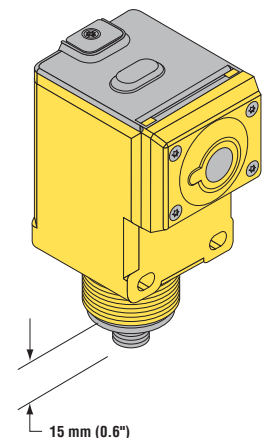

# U-GAGE™ Analog Q45U Ultrasonic Sensors

## Quick-Disconnect (QD) Cables

| Description                              | Model                                                             | Length                                              | Connector |
|------------------------------------------|-------------------------------------------------------------------|-----------------------------------------------------|-----------|
| 5-Pin Mini-style with shield             | <b>MBCC2-506</b><br><b>MBCC2-512</b><br><b>MBCC2-530</b>          | 2 meters (6.5')<br>4 meters (12')<br>9 meters (30') |           |
| 5-Pin Euro-style Straight with shield    | <b>MQDEC2-506</b><br><b>MQDEC2-515</b><br><b>MQDEC2-530</b>       | 2 meters (6.5')<br>5 meters (15')<br>9 meters (30') |           |
| 5-Pin Euro-style Right-angle with shield | <b>MQDEC2-506RA</b><br><b>MQDEC2-515RA</b><br><b>MQDEC2-530RA</b> | 2 meters (6.5')<br>5 meters (15')<br>9 meters (30') |           |



**WARNING . . .**  
Not to be used for personnel protection

**Never use these products as sensing devices for personnel protection. Doing so could lead to serious injury or death.**

These sensors do NOT include the self-checking redundant circuitry necessary to allow their use in personnel safety applications. A sensor failure or malfunction can cause either an energized or de-energized sensor output condition. Consult your current Banner Safety Products catalog for safety products which meet OSHA, ANSI, and IEC standards for personnel protection.

## Mounting Brackets

| Model          | Description                                                                                                                                                                                     | Dimensions                                                                                   |
|----------------|-------------------------------------------------------------------------------------------------------------------------------------------------------------------------------------------------|----------------------------------------------------------------------------------------------|
| <b>SMB30S</b>  | <ul style="list-style-type: none"> <li>30 mm swivel, black PBT bracket</li> <li>Stainless steel mounting hardware included</li> </ul>                                                           | <p>Not Shown:<br/>(2) M5 x 0.8 x 60 mm screws are supplied for clamping bracket together</p> |
| <b>SMB30C</b>  | <ul style="list-style-type: none"> <li>30 mm split clamp, black PBT bracket</li> <li>Stainless steel mounting hardware included</li> </ul>                                                      | <p>Nut Plate<br/>M5 x 0.8 x 80 mm Screw (2)</p>                                              |
| <b>SMB30MM</b> | <ul style="list-style-type: none"> <li>30 mm, 11-gauge, stainless steel bracket with curved mounting slots for versatility and orientation</li> <li>Clearance for M6 (1/4") hardware</li> </ul> |                                                                                              |

**WARRANTY:** Banner Engineering Corp. warrants its products to be free from defects for one year. Banner Engineering Corp. will repair or replace, free of charge, any product of its manufacture found to be defective at the time it is returned to the factory during the warranty period. This warranty does not cover damage or liability for the improper application of Banner products. This warranty is in lieu of any other warranty either expressed or implied.





# U-GAGE™ Q45U Ultrasonic Sensors

*Piezoelectric Proximity Mode Sensors with Push Button  
Programming of Sensing Window Limits – Bipolar Discrete Outputs*



- Analog models also available
- Models with other ranges also available

## Features

- Ultrasonic proximity detection from 100 to 1400 millimeters (4" to 55")
- Push button TEACH mode programming of sensing window limits
- Digital filtering for exceptional immunity to electrical and acoustic "noise"
- 12 to 24V dc operation
- Bipolar outputs: one NPN (sinking) and one PNP (sourcing)
- ON/OFF presence detection or HIGH/LOW level control are switch-selectable
- Wide operating temperature range of -25° to +70°C; models available with temperature compensation
- Rugged design for use in demanding sensing environments; rated IEC IP67, NEMA 6P
- Choose models with integral 2 m (6.5') or 9 m (30') cable, or with Mini-style or Euro-style quick-disconnect fitting
- External enable/disable feature for remote gating control

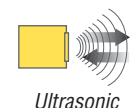
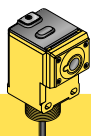

## Q45U Series Proximity Mode Sensor Models

| Models                                       | Temperature Compensation* | Range                        | Cable**                                      | Supply Voltage | Output Type        | Response Time                                           |
|----------------------------------------------|---------------------------|------------------------------|----------------------------------------------|----------------|--------------------|---------------------------------------------------------|
| Q45UBB63DA<br>Q45UBB63DAQ<br>Q45UBB63DAQ6    | No                        | 100 mm - 1.4 m<br>(4" - 55") | 2 m (6.5')<br>5-Pin Mini QD<br>5-Pin Euro QD | 12-24V dc      | Bipolar<br>NPN/PNP | Programmable for<br>20, 40, 160, or 640<br>milliseconds |
| Q45UBB63DAC<br>Q45UBB63DACQ<br>Q45UBB63DACQ6 | Yes                       |                              | 2 m (6.5')<br>5-Pin Mini QD<br>5-Pin Euro QD |                |                    |                                                         |

### \*Models with Temperature Compensation:

An increase in air temperature shifts both sensing window limits closer to the sensor. Conversely, a decrease in air temperature shifts both limits further away from the sensor. The shift is approximately 3.5% of the limit distance for a 20°C change in temperature.

Temperature compensated models maintain the position of both sensing window limits to within 1% of each limit distance over the range of from 0° to +50°C, and to within 2.5% over the full operating range of from -25° to +70°C.

### \*\*NOTES:

- 9 m (30') cables are available by adding suffix "W/30" to the model number of any cabled sensor (e.g., **Q45UBB63DA W/30**).
- A model with a QD connector requires an optional mating cable, see page 8.



### WARNING . . . Not To Be Used for Personnel Protection

**Never use these products as sensing devices for personnel protection. Doing so could lead to serious injury or death.**

These sensors do NOT include the self-checking redundant circuitry necessary to allow their use in personnel safety applications. A sensor failure or malfunction can cause either an energized or de-energized sensor output condition. Consult your current Banner Safety Products catalog for safety products which meet OSHA, ANSI and IEC standards for personnel protection.

# U-GAGE™ Q45U Ultrasonic Sensors with Bipolar Discrete Outputs

## Near and Far Sensing Limit Settings:

The Q45U features a single push button for programming of sensing window near and far limits (Figure 1). See the programming procedure on page 4.

## Status Indicators:

Status indicator LEDs are visible through the transparent, o-ring sealed Lexan® top cover. Indicator function in the **RUN** mode is, as follows:

- The green LED is on steadily whenever power is applied to the sensor, and flashes to indicate an overloaded output.
- The red LED lights when an echo is received, and flashes at a rate that is proportional to echo strength.
- The yellow LED lights whenever the outputs are conducting.

The 5-segment moving dot LED indicator displays the relative position of the target within the programmed sensing window. The #1 LED flashes when the target is closer than the near limit. The #5 LED flashes when the target is beyond the far limit.

## Output Response Settings:

**IMPORTANT:** Remove power before making any internal adjustments.

Using the two slots shown in Figure 1, a small flat-blade screwdriver may be used to lift up and remove the black inner cover to expose the 4-position DIP switch (Figure 2). Those switches are used to program the following functions:

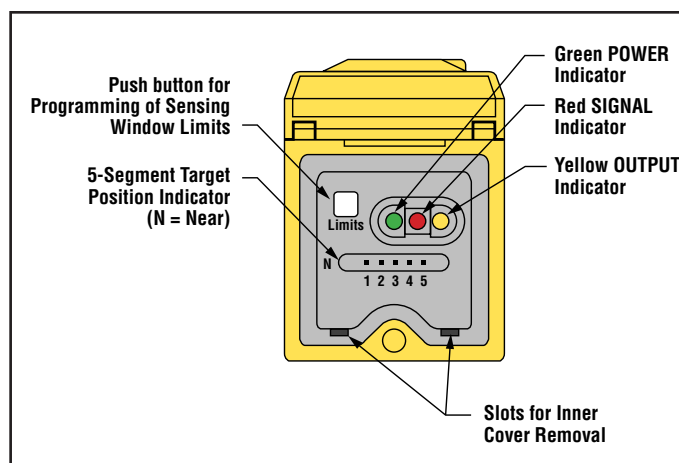

Figure 1. Q45U Features

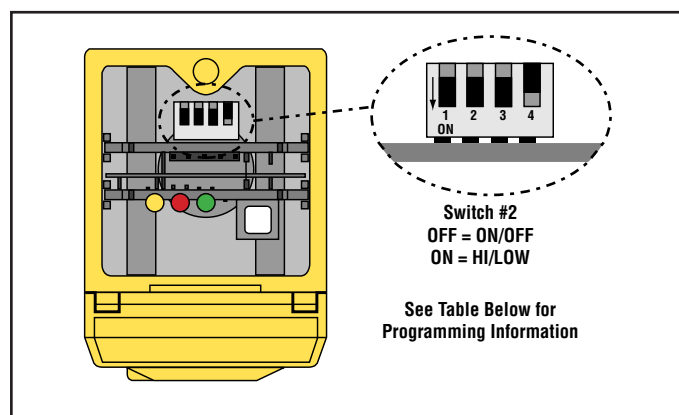

Figure 2. Q45U Programming Switches

| Switch | Function                                                                                                                                                  |                 |                                                        |
|--------|-----------------------------------------------------------------------------------------------------------------------------------------------------------|-----------------|--------------------------------------------------------|
| 1      | <b>ON/OFF</b> Mode<br>Output: On = normally closed (output energizes when target is absent)<br>Off* = normally open (output energizes when target sensed) |                 | <b>HIGH/LOW</b> Mode<br>On = Pump Out<br>Off = Pump In |
| 2      | Mode: On = <b>HIGH/LOW</b> (fill level control, see description, on page 3)<br>Off* = <b>ON/OFF</b> (output follows sensing action)                       |                 |                                                        |
| 3 - 4  | <b>Response</b> (20 ms/cycle)                                                                                                                             | <b>Switch 3</b> | <b>Switch 4</b>                                        |
|        | 1 Cycle                                                                                                                                                   | Off             | Off                                                    |
|        | 2 Cycles                                                                                                                                                  | On              | Off                                                    |
|        | 8 Cycles*                                                                                                                                                 | Off             | On                                                     |
|        | 32 Cycles                                                                                                                                                 | On              | On                                                     |

\*Denotes factory settings.

**NOTE:** Response setting of 2 cycles, or higher, is recommended for optimum sonic and electrical noise immunity. Always use the slowest acceptable response speed for your application. Single cycle update is only recommended for short range (<50 cm) applications looking for a stationary target (i.e. reflector).

# U-GAGE™ Q45U Ultrasonic Sensors with Bipolar Discrete Outputs

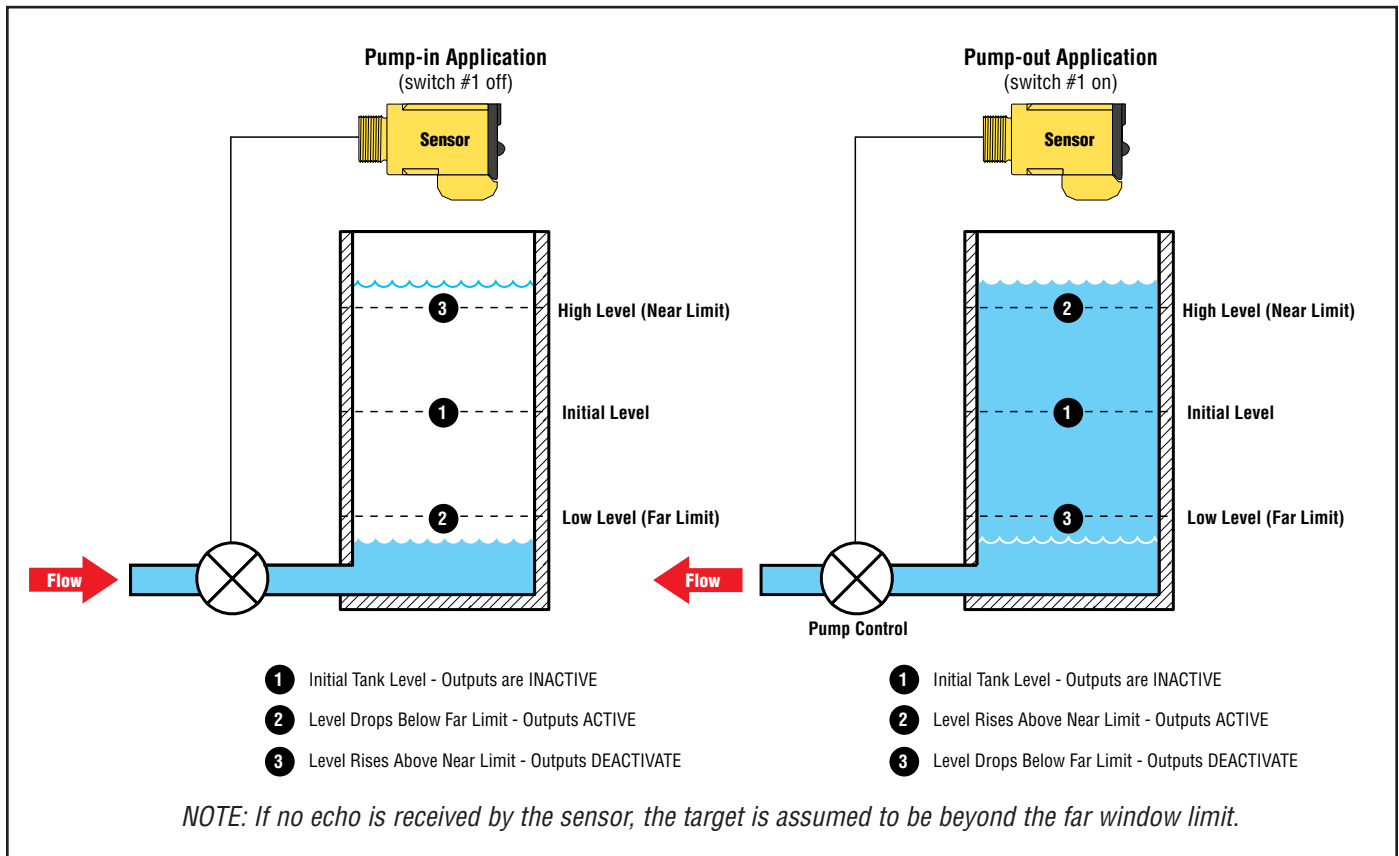



Figure 3. High/Low Level Control (switch #2 on)

The **HIGH/LOW** mode (switch #2 on) provides the switching logic required for fill-level, web tensioning control, and similar applications. In the HIGH/LOW mode, the output energizes when the target reaches the first sensing window limit, and stays energized until the target moves to the second limit. The output then de-energizes at the second limit and does not re-energize until the target moves, again, to the first limit. Figure 3 shows how pumping action might be controlled, directly, by the sensor in a fill-level application.

# U-GAGE™ Q45U Ultrasonic Sensors with Bipolar Discrete Outputs

## Window Limit Programming

The “Limits” push button, located under the transparent top cover, is used to program the near and the far limits. The near limit may be set as close as 100 millimeters (4”) and the far limit may be set as far as 1400 mm (55”) from the transducer face. Minimum window width is 10 mm (0.4”). Whenever possible, use the actual target to be sensed when setting the window limits. The following procedure begins with the sensor in RUN mode.

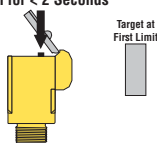
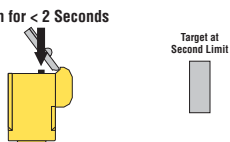
| Push Button                                                                                                                                                             |                                                                                                                                        | Indicator Status                                                                                                                                                                                                                                                                                                                                   |
|-------------------------------------------------------------------------------------------------------------------------------------------------------------------------|----------------------------------------------------------------------------------------------------------------------------------------|----------------------------------------------------------------------------------------------------------------------------------------------------------------------------------------------------------------------------------------------------------------------------------------------------------------------------------------------------|
| <p><b>Step 1</b></p> <p>Push and hold until green indicator turns off (approximately 2 seconds)</p>                                                                     | <p>Push and Hold for <math>\geq 2</math> Seconds</p>  | <p>Green: Goes off<br/>           Yellow: Is on steadily to indicate ready for teaching first limit<br/>           Red: Flashes to indicate strength of echo or is off if no target is present</p>                                                                                                                                                 |
| <p><b>Step 2</b></p> <p><b>FIRST LIMIT</b> (Near or Far)<br/>           Place the target at the first limit and press the push button for less than 2 seconds</p>       | <p>Push for <math>&lt; 2</math> Seconds</p>           | <p>Green: Remains off<br/>           Yellow: Flashes at 2 Hz to indicate ready for teaching second limit<br/>           Red: Comes on steadily for a moment, then resumes flashing to indicate strength of echo</p>                                                                                                                                |
| <p><b>Step 3</b></p> <p><b>SET SECOND LIMIT</b> (Far or Near)<br/>           Place the target at the second limit and press the push button for less than 2 seconds</p> | <p>Push for <math>&lt; 2</math> Seconds</p>          | <p>Green: Remains off, then comes on steadily (returns to <b>RUN</b> mode)<br/>           Yellow: On steadily for a moment, then is either on or off to indicate output state (returns to <b>RUN</b> mode)<br/>           Red: Comes on steadily for a moment, then resumes flashing to indicate strength of echo (returns to <b>RUN</b> mode)</p> |

### Notes regarding window limit programming:

- 1) Either the near or far limit may be programmed, first.
- 2) There is a 2-minute timeout for programming of the first limit. The sensor will return to RUN mode with the previously programmed limits. There is no timeout between programming of the first and second limit.
- 3) The programming sequence may be cancelled at any time by pressing and holding the push button for  $\geq 2$  seconds. The sensor returns to RUN mode with the previously programmed limits.
- 4) During limit programming, the 5-segment moving dot indicator displays the relative target position between 0 and 1500 millimeters (the maximum recommended far limit position is 1400 mm).
- 5) If the target is positioned between 1400 and 1500 mm, the 5th segment of the moving dot indicator flashes to indicate that a valid echo is received, but the target is beyond the recommended 1400 mm maximum far limit.
- 6) If a limit is rejected during either programming step, the sensor will revert to the first limit programming step (Step 2 in programming chart). This will be indicated by Green - off, Red - flashing to indicate signal strength, and Yellow - on steadily.
- 7) If both limits are accepted, the sensor will return to RUN mode, which is indicated by the Green LED coming on steadily.
- 8) If the target is held at the same position for programming of both limits, the sensor will establish a 10-mm wide sensing window, centered on the target position.

# U-GAGE™ Q45U Ultrasonic Sensors with Bipolar Discrete Outputs

## Q45U Series Sensor Specifications

|                                       |                                                                                                                                                                                                                                                                                                                                                                                                                                                              |
|---------------------------------------|--------------------------------------------------------------------------------------------------------------------------------------------------------------------------------------------------------------------------------------------------------------------------------------------------------------------------------------------------------------------------------------------------------------------------------------------------------------|
| <b>Proximity Mode Range</b>           | <b>Near limit:</b> 100 mm (4.0") min<br><b>Far limit:</b> 1.4 m (55") max                                                                                                                                                                                                                                                                                                                                                                                    |
| <b>Supply Voltage and Current</b>     | 12 to 24V dc (10% maximum ripple) at 100 mA, exclusive of load                                                                                                                                                                                                                                                                                                                                                                                               |
| <b>Supply Protection Circuitry</b>    | Protected against reverse polarity and transient voltages                                                                                                                                                                                                                                                                                                                                                                                                    |
| <b>Output Configuration</b>           | Bipolar: one current sourcing (PNP) and one current sinking (NPN) open-collector transistor. The following may be selected by a 4-position DIP switch located on top of the sensor, beneath a transparent o-ring sealed acrylic cover (see page 2):<br>Switch 1: Output normally open/normally closed (pump in/pump out)<br>Switch 2: High/Low level control mode or on/off presence sensing mode<br>Switch 3 & 4: Response speed selection (digital filter) |
| <b>Output Rating</b>                  | 150 mA maximum (each)<br><b>Off-state leakage current:</b> < 25 microamp at 24V dc<br><b>On-state saturation voltage:</b> < 1.5V at 10 mA; < 2.0V at 150 mA                                                                                                                                                                                                                                                                                                  |
| <b>Output Protection Circuitry</b>    | Protected against false pulse on power-up and continuous overload or short-circuit of outputs                                                                                                                                                                                                                                                                                                                                                                |
| <b>Performance Specifications</b>     | <b>Repeatability:</b> ±0.1% of measured distance (±0.25 mm min)<br><b>Minimum Window Width:</b> 10 mm (0.4")<br><b>Hysteresis:</b> 5 mm (0.2")                                                                                                                                                                                                                                                                                                               |
| <b>Indicators</b>                     | Three status LEDs:<br><b>Green ON steady</b> = power to sensor is ON<br><b>Green flashing</b> = output is overloaded<br><b>Yellow ON steady</b> = outputs are conducting (RUN mode)<br>programming status (SETUP mode)<br><b>Red flashing</b> = indicates relative strength of received echo<br>5-segment moving dot LED indicates the position of the target within the sensing window                                                                      |
| <b>Construction</b>                   | Molded PBT thermoplastic polyester housing, o-ring sealed transparent acrylic top cover, and stainless steel hardware. Q45U sensors are designed to withstand 1200 psi washdown. The base of cabled models has a 1/2"-14NPS internal conduit thread                                                                                                                                                                                                          |
| <b>Environmental Rating</b>           | Leakproof design is rated IEC IP67; NEMA 6P                                                                                                                                                                                                                                                                                                                                                                                                                  |
| <b>Connections</b>                    | 2 m (6.5') or 9 m (30') attached cable, or 5-pin Mini-style or 5-pin Euro-style quick-disconnect fitting                                                                                                                                                                                                                                                                                                                                                     |
| <b>Operating Conditions</b>           | <b>Temperature:</b> -25° to +70°C (-13° to +158°F)<br><b>Maximum relative humidity:</b> 100%                                                                                                                                                                                                                                                                                                                                                                 |
| <b>Vibration and Mechanical Shock</b> | All models meet Mil. Std. 202F requirements. Method 201A (Vibration: 10 to 60Hz max., double amplitude 0.06", maximum acceleration 10G). Method 213B conditions H & I (Shock: 75G with unit operating; 100G for non-operation) Also meets IEC 947-5-2 requirements: 30G, 11 ms duration, half sine wave.                                                                                                                                                     |
| <b>Hysteresis</b>                     | <b>ON/OFF mode:</b> 5 mm<br><b>HIGH/LOW mode:</b> 0 mm                                                                                                                                                                                                                                                                                                                                                                                                       |
| <b>Application Notes</b>              | <b>Minimum target size:</b> 10 mm x 10 mm aluminum plate at 500 mm (20")<br>35 mm x 35 mm aluminum plate at 1.4 m (55")<br><br><b>Enable/Disable:</b> Connect yellow wire to +5 to 24V dc to enable sensor and 0 to +2V dc to disable sensor. When the sensor is disabled, the last output state is held until the sensor is re-enabled. The wire must be held to the appropriate voltage for at least 40 ms for the sensor to enable or disable.            |

# U-GAGE™ Q45U Ultrasonic Sensors with Bipolar Discrete Outputs

## Q45U Response Curves

Q45U Effective Beam with Rod Target (Typical)

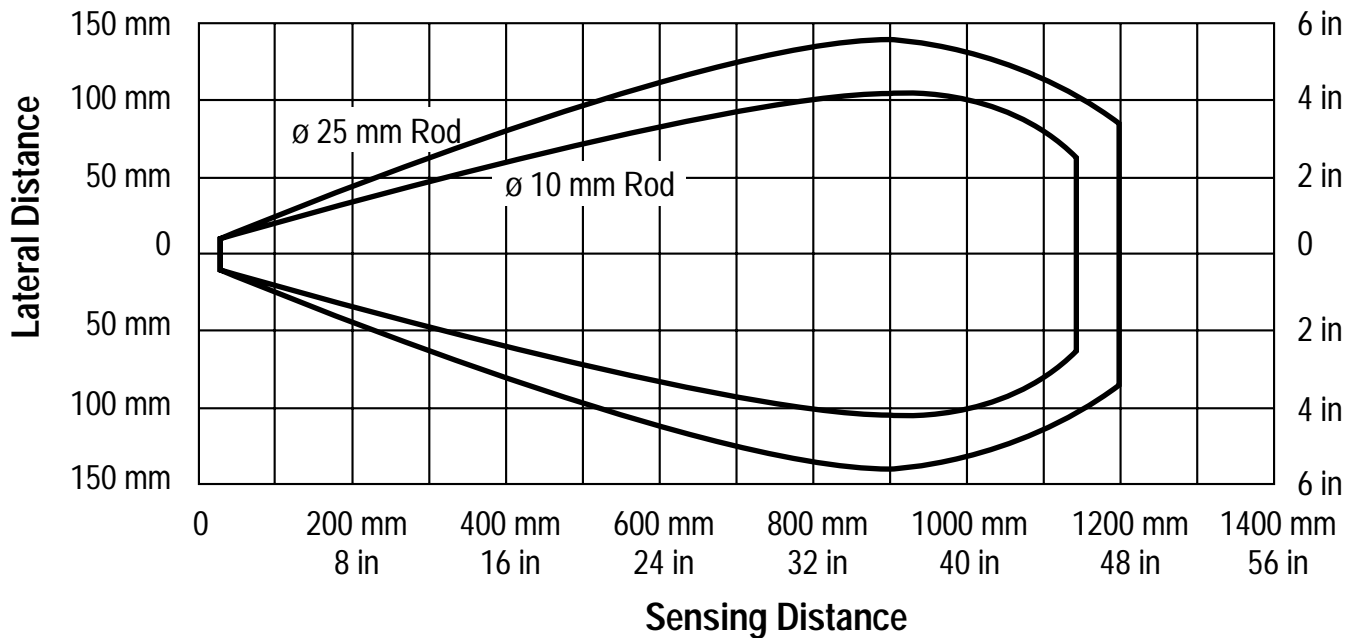

Q45U Effective Beam with Plate Target (Typical)

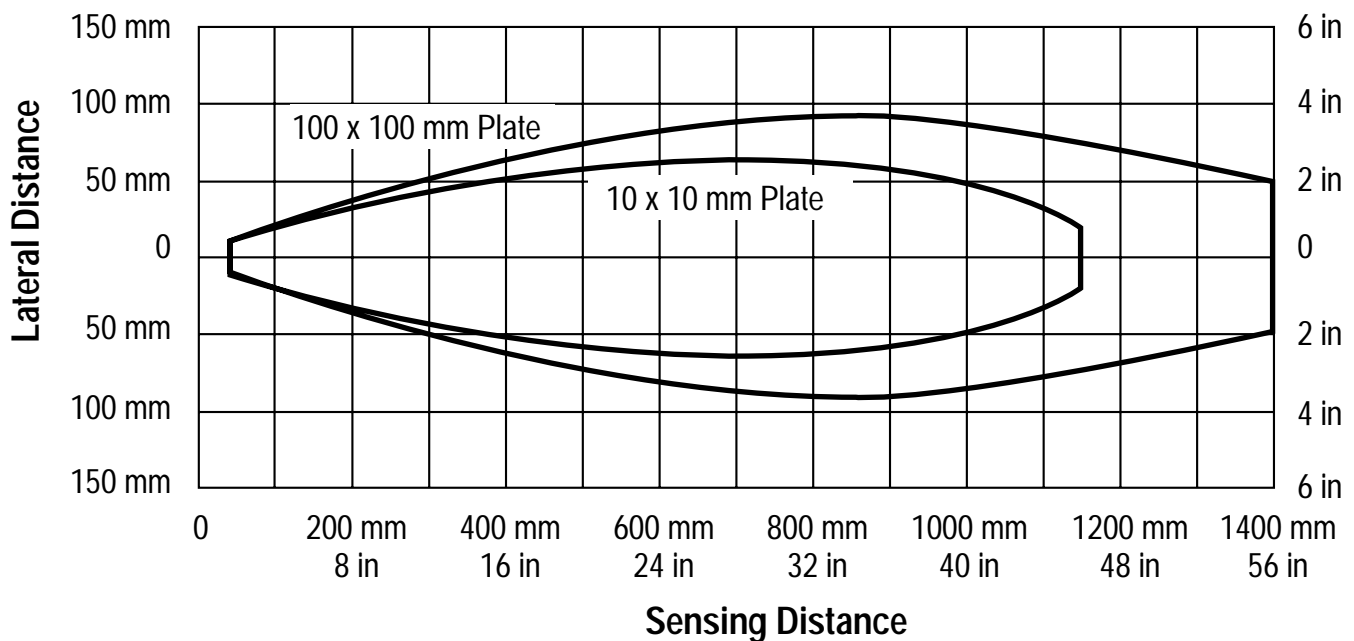

# U-GAGE™ Q45U Ultrasonic Sensors with Bipolar Discrete Outputs

## Q45U Series Hookup Diagrams

**Q45U Sensor with Attached Cable**

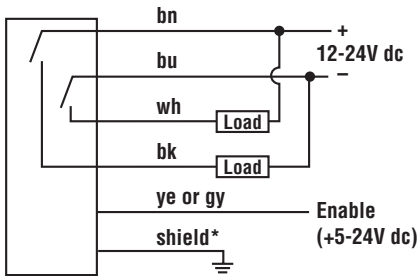

**Q45U Sensor with 5-Pin Mini-Style QD ("Q" model Suffix)**

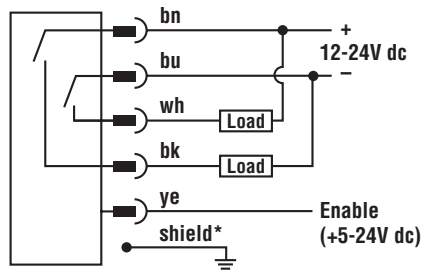

**Q45U Sensor with 5-Pin Euro-Style QD ("Q6" model Suffix)**

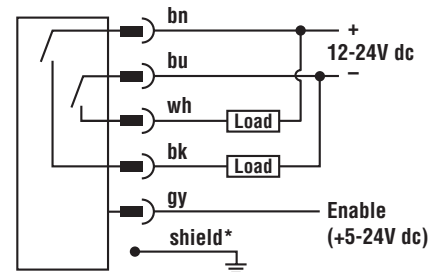

\*It is recommended that the shield wire be connected to earth ground or dc common.

**5-Pin Mini-Style Pin-out (Cable Connector Shown)**

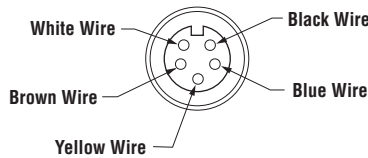

**5-Pin Euro-Style Pin-out (Cable Connector Shown)**

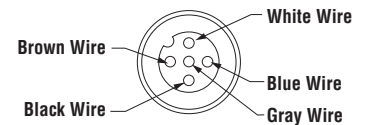

## Q45U Series Dimensions

**Q45U Sensor with Attached Cable**

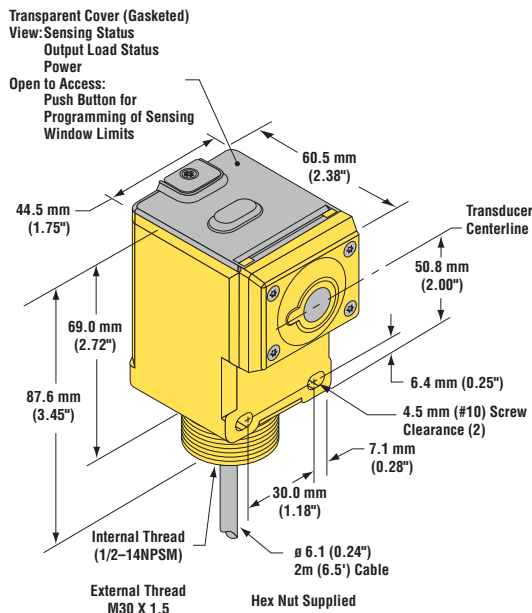

**Q45U Sensor with 5-Pin Mini-Style QD ("Q" model Suffix)**

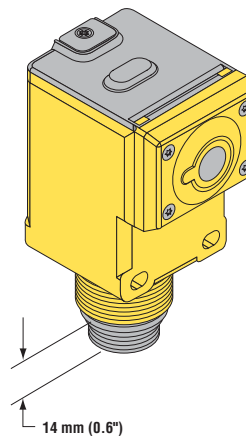

**Q45U Sensor with 5-Pin Euro-Style QD ("Q6" model Suffix)**

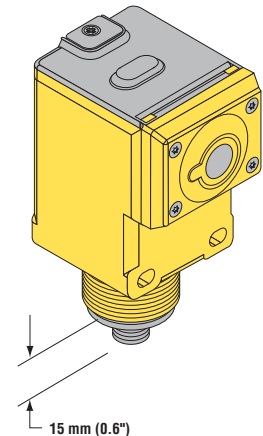

# U-GAGE™ Q45U Ultrasonic Sensors with Bipolar Discrete Outputs

| Mounting Brackets |                                                                                                                                                                                                     |
|-------------------|-----------------------------------------------------------------------------------------------------------------------------------------------------------------------------------------------------|
| <b>SMB30C</b>     | <ul style="list-style-type: none"> <li>• 30 mm split clamp, black PBT bracket</li> <li>• Stainless steel mounting hardware included</li> </ul>                                                      |
|                   |                                                                                                                                                                                                     |
| <b>SMB30S</b>     | <ul style="list-style-type: none"> <li>• 30 mm swivel, black PBT bracket</li> <li>• Stainless steel mounting hardware included</li> </ul>                                                           |
|                   |                                                                                                                                                                                                     |
| <b>SMB30MM</b>    | <ul style="list-style-type: none"> <li>• 30 mm, 11-gauge, stainless steel bracket with curved mounting slots for versatility and orientation</li> <li>• Clearance for M6 (1/4") hardware</li> </ul> |
|                   |                                                                                                                                                                                                     |

| Quick-Disconnect (QD) Cables             |                                                                   |                                      |           |
|------------------------------------------|-------------------------------------------------------------------|--------------------------------------|-----------|
| Style                                    | Model                                                             | Length                               | Connector |
| 5-Pin Mini-style with shield             | <b>MBCC2-506</b><br><b>MBCC2-512</b><br><b>MBCC2-530</b>          | 2 m (6.5')<br>4 m (12')<br>9 m (30') |           |
| 5-Pin Euro-style Straight with shield    | <b>MQDEC2-506</b><br><b>MQDEC2-515</b><br><b>MQDEC2-530</b>       | 2 m (6.5')<br>5 m (15')<br>9 m (30') |           |
| 5-Pin Euro-style Right-angle with shield | <b>MQDEC2-506RA</b><br><b>MQDEC2-515RA</b><br><b>MQDEC2-530RA</b> | 2 m (6.5')<br>5 m (15')<br>9 m (30') |           |

**WARRANTY:** Banner Engineering Corp. warrants its products to be free from defects for one year. Banner Engineering Corp. will repair or replace, free of charge, any product of its manufacture found to be defective at the time it is returned to the factory during the warranty period. This warranty does not cover damage or liability for the improper application of Banner products. This warranty is in lieu of any other warranty either expressed or implied.



## 45LMA Analog Output Card

For use with Analog Q45U Ultrasonic Proximity Mode Sensors



### Features

- Analog Output Card plugs into any Q45U ultrasonic proximity mode sensor in place of the existing output card.
- Selectable 0 to 10V dc voltage-sourcing or 4 to 20 mA current-sourcing analog outputs
- Selectable output slope: positive or negative as target distance increases

### Installing the 45LMA Card

Use the following procedure to install the 45LMA Analog Output Card:

- 1) Remove power from the Q45U sensor.
- 2) Remove the output card from the Q45U sensor (Figure 1). Use a small screwdriver, or similar tool, to dislodge the output card from its connector. Then, slide the card out of the sensor.
- 3) Slide the 45LMA card into the sensor in place of the sensor output card (Figure 3); push it firmly into place.
- 4) Configure DIP switches as necessary. See programming instructions and table for information.
- 5) Apply power to the sensor.

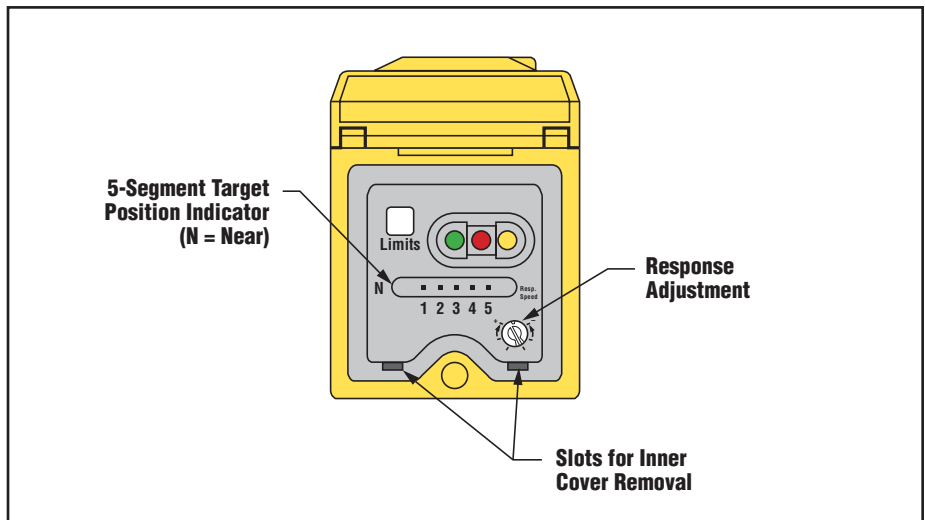

Figure 1. Analog Q45U (45LMA card) features

# Q45LMA Analog Output Card

## Programming the 45LMA Card

### Status Indicators:

Status indicator LEDs are visible through the transparent, o-ring sealed Lexan® top cover. Indicator function in the **RUN** mode is, as follows:

- The green LED is on steadily whenever power is applied to the sensor, and flashes to indicate a current output fault.
- The red LED lights when an echo is received, and flashes at a rate that is proportional to echo strength.
- The yellow LED lights whenever the target is within the operating window limits.

The 5-segment moving dot LED indicator displays the relative position of the target within the programmed sensing window. The #1 LED flashes when the target is closer than the near limit. The #5 LED flashes when the target is beyond the far limit.



Figure 2. Remove the output card using a small screwdriver to dislodge it from its connector.

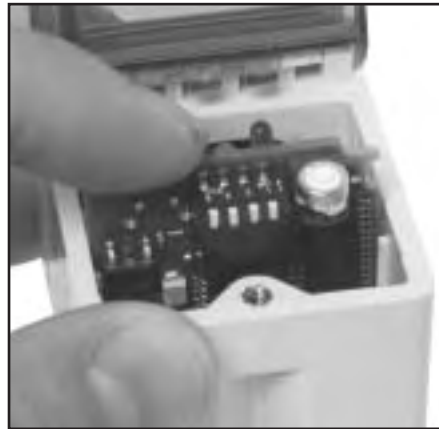

Figure 3. Slide the 45LMA card into the sensor and push it firmly into place.

|                                                    | Switch | Function            | Settings                                                                                               |
|----------------------------------------------------|--------|---------------------|--------------------------------------------------------------------------------------------------------|
| <p>See Table Below for Programming Information</p> | 1      | <b>Output Slope</b> | On = Output value <i>increases</i> with distance<br>Off* = Output value <i>decreases</i> with distance |
|                                                    | 2      | <b>Output Mode</b>  | On = Current output enabled<br>Off* = Voltage output enabled                                           |
|                                                    | 3      | <b>Loss of Echo</b> | On = Min - Max Mode<br>Off* = Hold Mode                                                                |
|                                                    | 4      | <b>Min - Max</b>    | On* = Default to maximum output value<br>Off = Default to minimum output value                         |
| *Indicates factory settings                        |        |                     |                                                                                                        |

Figure 4. 45LMA programming switches and their functions

### Output Response Settings:

**IMPORTANT:** Remove power before making any internal adjustments.

Using the two slots shown in Figure 1, a small flat-blade screwdriver may be used to lift up and remove the black inner cover to expose the 4-position DIP switch (Figure 2).

Those switches are used to program the functions as indicated in Figure 4.

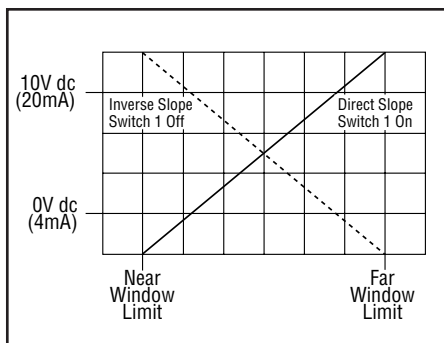

Figure 5. Output Slope

## Explanation of Programmable Output Functions:

### Switch 1: Output Slope Select

On = Direct = Output value (voltage or current) increases with increasing distance of the target from the sensor

Off\* = Inverse = Output value decreases with increasing distance of the target from the sensor

### Switch 2: Output Mode Select

On = The 4 to 20mA current output (white wire) is enabled

Off\* = The 0 to 10V dc voltage output (black wire) is enabled

This switch configures the D/A driver to use either the current output or the voltage output driver. **This output function can only be set with the power to the sensor turned off.**

### Switch 3: Loss of Echo Mode Select

On = Min - Max Mode

Off\* = Hold Mode

This switch determines the output response to the loss of echo. The “Hold Mode” (Switch 3 Off\*) maintains the output at the value which was present at the time of echo loss. The “Min - Max Mode” (Switch 3 On) drives the output to either the minimum value (0V or 4mA or the maximum value (10V or 20mA) when the echo is lost. Minimum or maximum value is selected by Switch 4.

### Switch 4: Min - Max Default

On\* = Default to maximum output value at loss of echo

Off = Default to minimum output value at loss of echo

Switch 4 selects the output response to loss of echo when “Min - Max Mode” is selected by Switch 3 (see above).

### Response Speed Adjustment

The speed of the output response is set using the single-turn potentiometer (see Figures 1 and 6). There are six values for response speed, which relate directly to the number of sensing cycles over which the output value is averaged. The response value is set by aligning the slot of the potentiometer with one of the marked positions. The positions and their corresponding settings are identified in Figure 6.

| Response Speed Settings                                                                                                       |          |                               |
|-------------------------------------------------------------------------------------------------------------------------------|----------|-------------------------------|
|                                                                                                                               | Position | Response Speed                |
| <p>NOTE: This example shows the potentiometer set at position number 4. There are no numbers on the actual product label.</p> | 1        | 40 milliseconds (2 cycles)    |
|                                                                                                                               | 2        | 80 milliseconds (4 cycles)    |
|                                                                                                                               | 3        | 160 milliseconds (8 cycles)   |
|                                                                                                                               | 4        | 320 milliseconds (16 cycles)  |
|                                                                                                                               | 5        | 640 milliseconds (32 cycles)  |
|                                                                                                                               | 6        | 1280 milliseconds (64 cycles) |

Figure 6. Response adjustment positions and their corresponding response speed values