

## Features

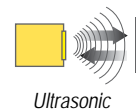

- Fast, easy-to-use TEACH-Mode programming; no potentiometer adjustments
- Ultra-compact housing
- One discrete output: NPN or PNP, depending on model
- Two bi-colored status LEDs
- Rugged encapsulated version for harsh environments
- Choose 2 meter or 9 meter unterminated cable, 4-pin Euro-style or 4-pin Pico-style QD connectors (either integral or with 150 mm pigtail)
- Wide operating range of -20° to +60° C (-13° to +140° F)
- Temperature compensation
- Configurable for normally open or normally closed operation
- Fast response time (15 milliseconds)



## Models

Model	Sensing Range	TEACH Options	Cable*	Supply Voltage	Output
QS18UNA	50 mm to 500 mm (2" to 20")	Integral push button or remote TEACH (IP67, NEMA 6P)	4-wire, 2 m (6.5') cable with shield	12-30V dc	NPN
QS18UPA					PNP
QS18UNAE		Remote TEACH (epoxy-encapsulated, IP68, NEMA 6P)			NPN
QS18UPAE					PNP

\*Only standard 2 m (6.5') cable models are listed. For 9 m (30') shielded cable, add suffix "W/30" to the model number (e.g., QS18UNA W/30).

QD models:

- For 4-pin integral Euro-style QD, add suffix "Q8" (e.g., QS18UNAQ8).
- For 4-pin Euro-style 150 mm (6") pigtail QD, add suffix "Q5" (e.g., QS18UNAQ5).
- For 4-pin integral Pico-style QD, add suffix "Q7" (e.g., QS18UNAQ7).
- For 4-pin Pico-style 150 mm (6") pigtail QD, add suffix "Q" (e.g., QS18UNAQ).

A model with a QD connector requires a mating cable (see page 10).



### WARNING . . . Not To Be Used for Personnel Protection

Never use these products as sensing devices for personnel protection. Doing so could lead to serious injury or death.

These sensors do NOT include the self-checking redundant circuitry necessary to allow their use in personnel safety applications. A sensor failure or malfunction can cause either an energized or de-energized sensor output condition. Consult your current Banner Safety Products catalog for safety products which meet OSHA, ANSI and IEC standards for personnel protection.

# WORLD BEAM® QS18U Series Ultrasonic Sensors

---

## Principles of Operation

Ultrasonic sensors emit one or multiple pulses of ultrasonic energy, which travel through the air at the speed of sound. A portion of this energy reflects off the target and travels back to the sensor. The sensor measures the total time required for the energy to reach the target and return to the sensor. The distance to the object is then calculated using the following formula:

$$D = \frac{ct}{2}$$

D = distance from the sensor to the target  
c = speed of sound in air  
t = transit time for the ultrasonic pulse

To improve accuracy, an ultrasonic sensor may average the results of several pulses before outputting a new value.

### Temperature Effects

The speed of sound is dependent upon the composition, pressure and temperature of the gas in which it is traveling. For most ultrasonic applications, the composition and pressure of the gas are relatively fixed, while the temperature may fluctuate.

In air, the speed of sound varies with temperature according to the following approximation:

$$C_{m/s} = 20 \sqrt{273 + T_C}$$

C<sub>m/s</sub> = speed of sound in meters per second  
T<sub>C</sub> = temperature in °C

Or, in English units:

$$C_{ft/s} = 49 \sqrt{460 + T_F}$$

C<sub>ft/s</sub> = speed of sound in feet per second  
T<sub>F</sub> = temperature in °F

### Temperature Compensation

Changes in air temperature affect the speed of sound, which in turn affects the distance reading measured by the sensor. An increase in air temperature shifts both sensing window limits closer to the sensor. Conversely, a decrease in air temperature shifts both limits farther away from the sensor. This shift is approximately 3.5% of the limit distance for a 20° C change in temperature.

The QS18U series ultrasonic sensors are temperature compensated. This reduces the error due to temperature by about 90%. The sensor will maintain its window limits to within 1.8% over the -20° to +60° C range.

#### NOTES:

- Exposure to direct sunlight can affect the sensor's ability to accurately compensate for changes in temperature.
- If the sensor is measuring across a temperature gradient, the compensation will be less effective.
- The temperature warmup drift upon power-up is less than 7% of the sensing distance. After 5 minutes, the apparent switchpoint will be within 0.6% of the actual position. After 25 minutes, the sensing position will be stable.

# WORLD BEAM® QS18U Series Ultrasonic Sensors

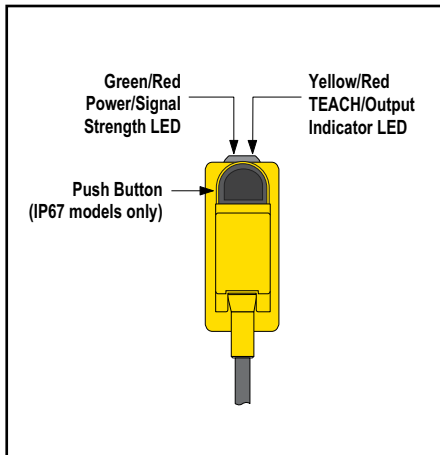

Figure 1. Sensor features

## Sensor Programming

Two TEACH methods may be used to program the sensor:

- Teach individual minimum and maximum limits, or
- Use Auto-Window feature to center a sensing window around the taught position.

The sensor may be programmed either via its push button, or via a remote switch. Remote programming also may be used to disable the push button, preventing unauthorized personnel from adjusting the programming settings. To access this feature, connect the white wire of the sensor to 0V dc, with a remote programming switch between the sensor and the voltage.

Programming is accomplished by following the sequence of input pulses (see programming procedures starting on page 4). The duration of each pulse (corresponding to a push button "click"), and the period between multiple pulses, are defined as "T":

$$0.04 \text{ seconds} < T < 0.8 \text{ seconds}$$

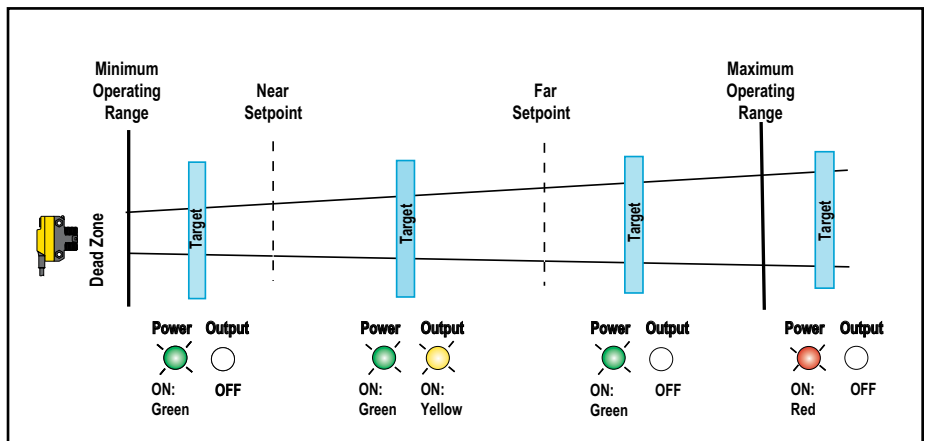

Figure 2. TEACH Interface

## Status Indicators

Power ON/OFF LED	Indicates
OFF	Power is OFF.
ON Red	Target is weak or outside sensing range.
ON Green	Sensor is operating normally, good target.

Output/Teach LED	Indicates
OFF	Target is outside window limits (normally open operation).
Yellow	Target is within window limits (normally open operation).
ON Red (solid)	In Teach Mode, waiting for first limit
ON Red (flashing)	In Teach Mode, waiting for second limit

# WORLD BEAM® QS18U Series Ultrasonic Sensors

## Teaching Minimum and Maximum Limits

### General Notes on Programming

- The sensor will return to RUN mode if the first TEACH condition is not registered within 120 seconds.
- After the first limit is taught, the sensor will remain in PROGRAM mode until the TEACH sequence is finished.
- To exit PROGRAM mode without saving any changes, press and hold the programming push button > 2 seconds (before teaching the second limit). The sensor will revert to the last saved limits.

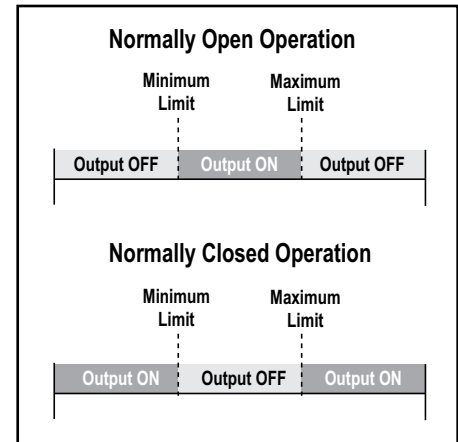







Figure 3. Teaching independent minimum and maximum limits

	Procedure		Result
	Push Button 0.04 sec. < "click" < 0.8 sec.	Remote Line 0.04 sec. < T < 0.8 sec.	
Programming Mode	<ul style="list-style-type: none"> <li>• Push and hold push button</li> </ul> 	<ul style="list-style-type: none"> <li>• No action required; sensor is ready for 1st limit teach</li> </ul>	Output LED: ON Red Power LED: ON Green (good signal) or ON Red (no signal)
Teach First Limit	<ul style="list-style-type: none"> <li>• Position the target for the first limit</li> </ul>	<ul style="list-style-type: none"> <li>• Position the target for the first limit</li> </ul>	Power LED: Must be ON Green
	<ul style="list-style-type: none"> <li>• "Click" the push button</li> </ul> 	<ul style="list-style-type: none"> <li>• Single-pulse the remote line</li> </ul> 	Teach Accepted Output LED: Flashing Red Teach Unacceptable Output LED: ON Red
Teach Second Limit	<ul style="list-style-type: none"> <li>• Position the target for the second limit</li> </ul>	<ul style="list-style-type: none"> <li>• Position the target for the second limit</li> </ul>	Power LED: Must be ON Green
	<ul style="list-style-type: none"> <li>• "Click" the push button</li> </ul> 	<ul style="list-style-type: none"> <li>• Single-pulse the remote line</li> </ul> 	Teach Accepted Output LED: Yellow or OFF Teach Unacceptable Output LED: Flashing Red

# WORLD BEAM® QS18U Series Ultrasonic Sensors

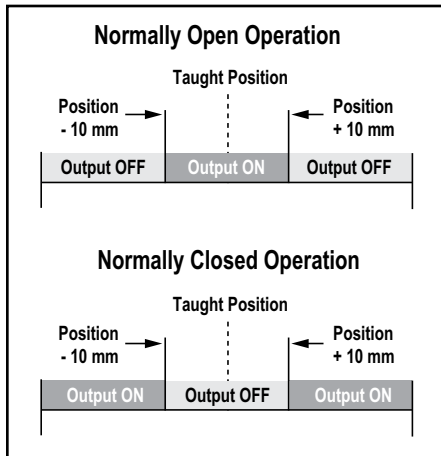







Figure 4. Using the Auto-Window feature for programming each output

## Teaching Limits Using the Auto-Window Feature

Teaching the same limit twice automatically centers a 20 mm window on the taught position.

### General Notes on Programming

- The sensor will return to RUN mode if the first TEACH condition is not registered within 120 seconds.
- After the first limit is taught, the sensor will remain in PROGRAM mode until the TEACH sequence is finished.
- To exit PROGRAM mode without saving any changes, press and hold the programming push button > 2 seconds (before teaching the second limit). The sensor will revert to the last saved program.

	Procedure		Result
	Push Button 0.04 sec. < "click" < 0.8 sec.	Remote Line 0.04 sec. < T < 0.8 sec.	
Programming Mode	<ul style="list-style-type: none"> <li>• Push and hold push button</li> </ul> 	<ul style="list-style-type: none"> <li>• No action required; sensor is ready for 1st limit teach</li> </ul>	Output LED: ON Red Power LED: ON Green (good signal) or ON Red (no signal)
Teach Limit	<ul style="list-style-type: none"> <li>• Position the target for the first limit</li> </ul>	<ul style="list-style-type: none"> <li>• Position the target for the center of window</li> </ul>	Power LED: Must be ON Green
	<ul style="list-style-type: none"> <li>• "Click" the push button</li> </ul> 	<ul style="list-style-type: none"> <li>• Single-pulse the remote line</li> </ul> 	Teach Accepted Output LED: Flashing Red Teach Unacceptable Output LED: ON Red
Re-Teach Limit	<ul style="list-style-type: none"> <li>• Without moving the target, "click" the push button again</li> </ul> 	<ul style="list-style-type: none"> <li>• Without moving the target, single-pulse the remote line again</li> </ul> 	Teach Accepted Output LED: Yellow or OFF Teach Unacceptable Output LED: Flashing Red

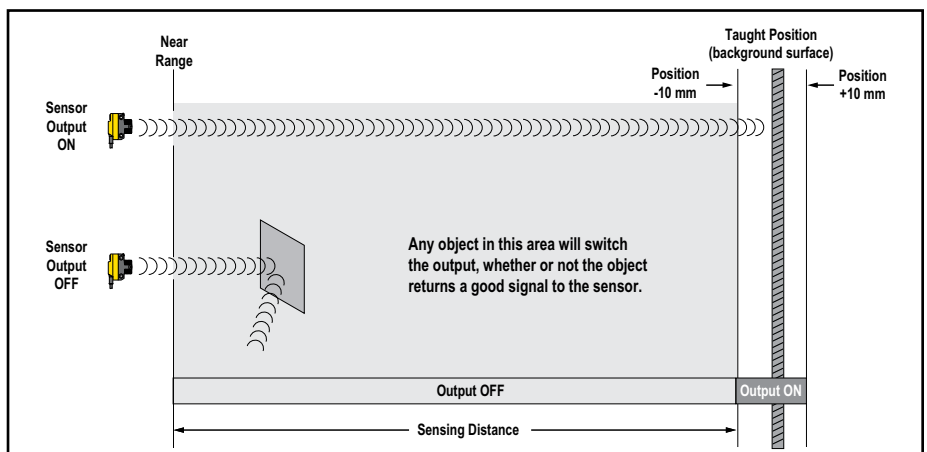
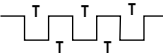

Figure 5. An application for the Auto-Window feature (retroreflective mode)

# WORLD BEAM® QS18U Series Ultrasonic Sensors

## Normally Open/Normally Closed Operation Select

The sensor can be configured for either normally open or normally closed operation via the remote teach wire (white). A series of three pulses on the line will toggle between normally open and normally closed operation. Normally open is defined as the output energizing when the target is present. Normally closed is defined as the output energizing when the target is absent. See Figures 3 and 4.

	Procedure		Result
	Push Button	Remote Line 0.04 sec. < T < 0.8 sec.	
Toggle between N.O. / N.C. Operation	<ul style="list-style-type: none"> <li>Not available via push button</li> </ul>	<ul style="list-style-type: none"> <li>Triple-pulse the remote line</li> </ul> 	<ul style="list-style-type: none"> <li>Either Normally Open or Normally Closed operation is selected, depending on previous condition.</li> </ul>

## Push Button Lockout

Enables or disables the push button to prevent unauthorized personnel from adjusting the program settings.

	Procedure		Result
	Push Button	Remote Line 0.04 sec. < T < 0.8 sec.	
Push Button Lockout	<ul style="list-style-type: none"> <li>Not available via push button</li> </ul>	<ul style="list-style-type: none"> <li>Four-pulse the remote line</li> </ul> 	<ul style="list-style-type: none"> <li>Push buttons are either enabled or disabled, depending on condition.</li> </ul>

# WORLD BEAM® QS18U Series Ultrasonic Sensors

## Specifications

Sensing Range	50 to 500 mm (2" to 20")	
Supply Voltage	12 to 30V dc (10% maximum ripple); 25 mA max. (exclusive of load)	
Ultrasonic Frequency	300 kHz, rep. rate 7.5 ms	
Supply Protection Circuitry	Protected against reverse polarity and transient voltages	
Output Configuration	SPST solid-state switch conducts when target is sensed within sensing window; one NPN (current sinking) or one PNP (current sourcing), depending on model.	
Output Protection	Protected against short circuit conditions	
Output Ratings	100 mA maximum OFF-state leakage current: < 10 microamps (sourcing); < 200 microamp (sinking) NPN saturation: < 1.6V @ 100 mA PNP saturation: < 2.0V @ 100 mA	
Output Response Time	15 milliseconds	
Delay at Power-Up	300 milliseconds	
Temperature Effect	Non-encapsulated models: $\pm 0.05\%$ per °C from -20° to +50° C, $\pm 0.1\%$ per °C from +50° to +60° C Encapsulated models: $\pm 0.05\%$ per °C from 0° to +60° C, $\pm 0.1\%$ per °C from -20° to 0° C	
Repeatability	0.7 mm	
Minimum Window Size	5 mm	
Hysteresis	1.4 mm	
Adjustments	Sensing window limits: TEACH-Mode programming of near and far window limits may be set using the push button or remotely via TEACH input (see page 3).	
Indicators	<b>Range Indicator (Red/Green)</b> Green — Target is within sensing range Red — Target is outside sensing range OFF — Sensing power is OFF	<b>Teach/Output Indicator (Yellow/Red)</b> Yellow — Target is within taught limits OFF — Target is outside taught window limits Red — Sensor is in TEACH mode
Construction	Housing: ABS Push Button: TPE	Push Button Housing: ABS Lightpipes: Polycarbonate
Operating Conditions	Temperature: -20° to +60° C (-4° to +140° F) Maximum relative humidity: 100%, non-condensing	
Connections	2 m (6.5') or 9 m (30') 4-conductor PVC jacketed attached cable or 4-pin Euro-style integral QD (Q8), or 4-pin Pico-style integral QD (Q7), or 4-pin Euro-style 150 mm (6") pigtail QD (Q5), or 4-pin Pico-style 150 mm (6") pigtail QD (Q)	
Environmental Rating	Leakproof design, rated NEMA 6P; IEC IP67 or IP68, depending on model (see page 1)	
Vibration and Mechanical Shock	All models meet Mil. Std. 202F requirements method 201A (vibration: 10 to 60 Hz max., double amplitude 0.06", maximum acceleration 10G). Also meets IEC 947-5-2 requirements: 30G 11 ms duration, half sine wave.	
Temperature Warmup Drift	See Temperature Compensation, page 2	
Application Notes	Objects passing inside the specified near limit may produce a false response.	
Certifications	Approvals are pending	

# WORLD BEAM® QS18U Series Ultrasonic Sensors

## Sensor Response Curves

QS18U Effective Beam Pattern (Typical)

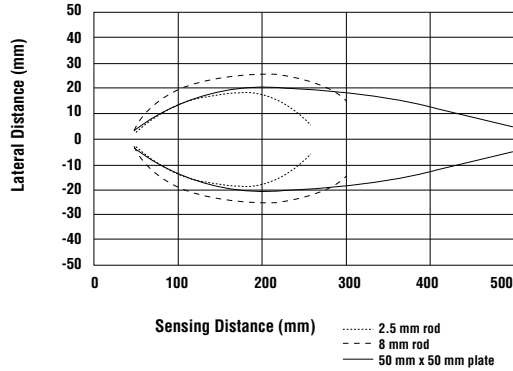

QS18U Maximum Target Rotation Angle

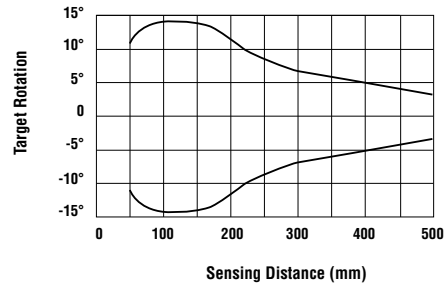

## Hookups

NPN (Sinking) Output Models

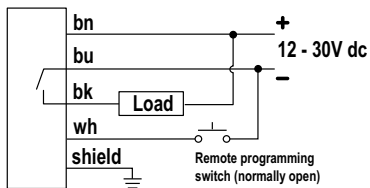

PNP (Sourcing) Output Models

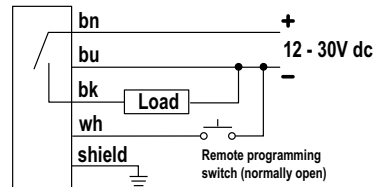

Cable and QD hookups are functionally identical.

It is recommended that the shield wire be connected to earth ground. Shielded cordsets are recommended for all QD models.

## Dimensions

Cabled Models

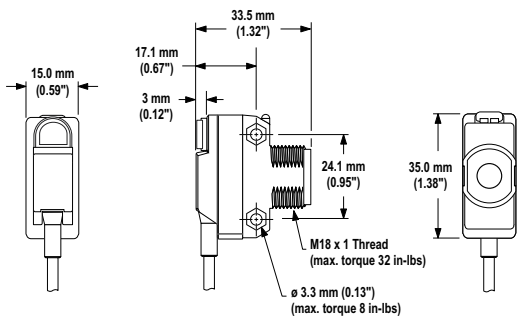

Pico-Style QD Models

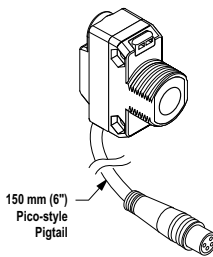

Euro-Style QD Models

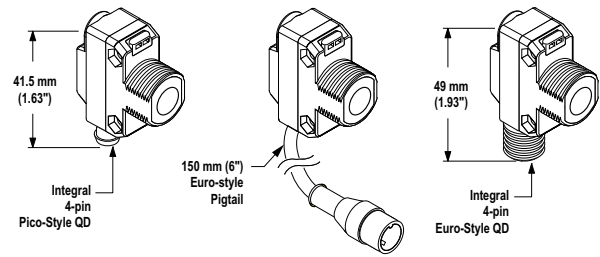

Locknut (Included with All Models)

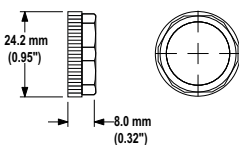

Washer (Included with All Models)

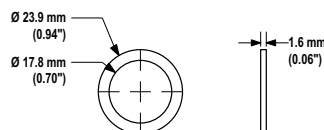

### M3 Hardware Packet Contents:

- 2 - M3 x 0.5 x 20 mm SS Screw
- 2 - M3 x 0.5 SS Hex Nut
- 2 - M3 SS Washer

# WORLD BEAM® QS18U Series Ultrasonic Sensors

## Accessories

### Quick-Disconnect Cables

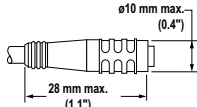
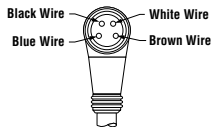
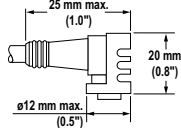
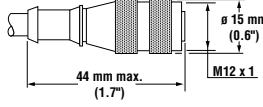
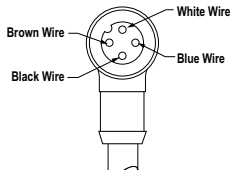
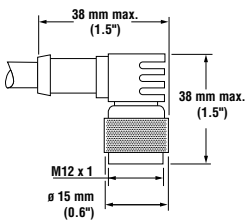
Style	Model	Length	Dimensions	Pinout
4-pin Pico-style Straight with shield, snap-on connector	PKG4S-2	2 m (6.5')		
4-pin Pico-style Right-angle with shield, snap-on connector	PKW4ZS-2	2 m (6.5')		
4-pin Euro-style Straight with shield	MQDEC2-406 MQDEC2-415 MQDEC2-430	2 m (6.5') 5 m (15') 9 m (30')		
4-pin Euro-style Right-angle with shield	MQDEC2-406RA MQDEC2-415RA MQDEC2-430RA	2 m (6.5') 5 m (15') 9 m (30')		

# WORLD BEAM® QS18U Series Ultrasonic Sensors

## Mounting Brackets

<p><b>SMBQS18RA</b></p>	<ul style="list-style-type: none"> <li>• 304 stainless steel</li> <li>• Right-angle bracket</li> <li>• NOTE: Integral QD models must mount to the "outside" to allow clearance</li> </ul>	<p><b>SMB18A</b></p>	<ul style="list-style-type: none"> <li>• 12-gauge, stainless steel, right-angle mounting bracket with a curved mounting slot for versatility and orientation</li> <li>• Clearance for M4 (#8) hardware</li> </ul>
		<p>* Use 4 mm (#8) screws to mount bracket. Drill screw holes 24.2 mm (0.95") apart.</p>	
<p><b>SMB18SF</b></p>	<ul style="list-style-type: none"> <li>• 18 mm swivel bracket</li> <li>• Black thermoplastic polyester</li> <li>• Includes stainless steel hardware</li> </ul>	<p><b>SMB18UR</b></p>	<ul style="list-style-type: none"> <li>• 2-piece universal 18 mm swivel bracket</li> <li>• 300 series stainless steel</li> <li>• Includes stainless steel swivel locking hardware</li> </ul>
<p>M18 x 1 internal thread</p>		<p>SMB18UR Top</p>	<p>SMB18UR Bottom</p>