



## Features

- Positive opening safety contacts (IEC 60947-5-1) (not dependent upon springs)
- Limit switch design (EN 50047)
- Mechanically-coded actuators utilize two independent operating elements to minimize intentional tampering or defeat
- Rotating head allows actuator engagement from four sides or four top positions; no tools are required to rotate head
- Low-profile design for limited space requirements; only 30.5 mm (1.3") depth
- Tough, glass-reinforced thermoplastic housing; metal actuator
- Choice of two in-line actuators or a flexible actuator
- Insulated device (IEC 60947-5-1)

## Models

Kit Model†	Actuator Type†	Interlock Body†	Contact Configuration (Actuator Engaged)	Contact Configuration (Actuator Removed)	Switching Diagrams
SI-LS100SF	SI-QS-SSA-2 Straight Rigid In-Line	SI-LS100F	Two N.C. and One N.O. Contact		
SI-LS100SRAF	SI-QS-SSA-3 Right-angle In-Line				
SI-LS100SRFF (Direct replacement for models SI-LS100MRHF and SI-LS100MRVF)	SI-QS-SSU Flexible In-Line				
SI-LS83SD	SI-QS-SSA-2 Straight Rigid In-Line	SI-LS83D	One N.C. and One N.O. Contact		
SI-LS83SRAD	SI-QS-SSA-3 Right-angle In-Line				
SI-LS83MRFD (Direct replacement for models SI-LS83MRHD and SI-LS83MRVD)	SI-QS-SSU Flexible In-Line				

NOTE: This symbol is used in the switching diagrams to identify the point in actuator travel where the normally closed safety contact is fully open.

† A kit contains an interlock and actuator. Individual interlock bodies or actuators are for replacement purposes only. See Warning on page 8.

Contacts: Open Closed Transition

# Machine Safety Switches – SI-LS83 and SI-LS100 Series

## Important Information Regarding the Use of Safety Switches

In the United States, the functions that Banner safety switches are intended to perform are regulated by the Occupational Safety and Health Administration (OSHA). Whether or not any particular safety switch installation meets all applicable OSHA requirements depends upon factors that are beyond the control of Banner Engineering Corp. These factors include the details of how the safety switches are applied, installed, wired, operated, and maintained.

Banner Engineering Corp. has attempted to provide complete application, installation, operation, and maintenance instructions. This information is found in the instruction manual packaged with each safety switch. In addition, we suggest that any questions regarding the use or installation of safety switches be directed to the factory applications department at the telephone numbers or address shown below.

Banner Engineering Corp. recommends that safety switches be applied according to the guidelines set forth in international (ISO/IEC) standards listed below. Specifically, Banner Engineering Corp. recommends application of these safety switches in a configuration which meets safety category 4, per ISO 13849 (EN954-1).

In addition, the user of Banner safety switches has the responsibility to ensure that all local, state, and national laws, rules, codes, and regulations relating to the use of Banner safety switches in any particular application are satisfied. Extreme care is urged that all legal requirements have been met and that all installations and maintenance instructions are followed.

### Application Assistance

**Toll Free:** 1-888-3-SENSOR (1-888-373-6767)  
**Email:** sensors@bannerengineering.com  
**Address:** 9714 Tenth Avenue North  
Minneapolis, MN 55441

### U.S. Regulations Applicable to Use of Banner Safety Switches

OSHA Code of Federal Regulations: Title 29, Parts 1900 to 1910

Available from: Superintendent of Documents  
Government Printing Office  
P.O. Box 371954  
Pittsburgh, PA 15250-7954  
Tel: 202-512-1800

### U.S. Standards Applicable to Use of Banner Safety Switches

ANSI B11 "Standards for Construction, Care, and Use of Machine Tools"  
Available from: Safety Director  
AMT—The Association for Manufacturing Technology  
7901 Westpark Drive  
McLean, VA 22102  
Tel: 703-893-2900

### Applicable European and International Standards

ISO/TR 12100-1 "Safety of Machinery—Basic Concepts, General Principles for Design"  
(EN 292-1/-2)  
ISO 13852 (EN 294) "Safety of Machinery—Safety Distances to Prevent Danger Zones Being Reached by the Upper Limbs"  
ISO 13853 (EN 811) "Safety of Machinery—Safety Distances to Prevent Danger Zones Being Reached by the Lower Limbs"  
ISO 13849-1 (EN 954-1) "Safety of Machinery—Safety Related Parts of Control Systems"  
ISO 13855 (EN 999) "Safety of Machinery—The Positioning of Protective Equipment in Respect to Approach Speeds of Parts of the Human Body"  
ISO 14119 (EN 1088) "Safety of Machinery—Interlocking Devices Associated with Guards—Principles for Design and Selection"  
IEC/EN 60204-1 "Safety of Machinery—Electrical Equipment of Machines"  
IEC/EN 60947-5-1 "Low Voltage Switchgear—Electromechanical Control Circuit Devices"

Available from: Global Engineering Documents  
15 Inverness Way East  
Englewood, CO 80112-5704  
Phone: 1-800-854-7179  
Fax: 303-397-2740

# Machine Safety Switches – SI-LS83 and SI-LS100 Series

## Models, continued

Kit Model†	Actuator Type†	Interlock Body†	Contact Configuration (Actuator Engaged)	Contact Configuration (Actuator Removed)	Switching Diagrams
SI-LS83SE	SI-QS-SSA-2 Straight Rigid In-Line	SI-LS83E	Two N.C. Contacts		
SI-LS83SRAE	SI-QS-SSA-3 Right-angle In-Line				
SI-LS83MRFE (Direct replacement for models SI-LS83MRHE and SI-LS83MRVE)	SI-QS-SSU Flexible In-Line				

NOTE: This symbol is used in the switching diagrams to identify the point in actuator travel where the normally closed safety contact is fully open.

Contacts: Open Closed Transition

† A kit contains an interlock and actuator. Individual interlock bodies or actuators are for replacement purposes only. See Warning on page 8.

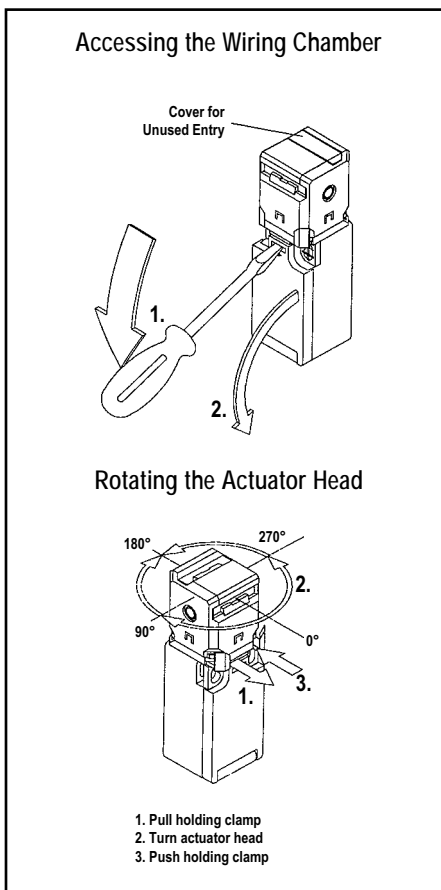

Figure 1. Features

## Overview

### Easy Access

The wiring chamber is accessed via a hinged door. Simply insert a flat-blade screwdriver, as shown, and pry gently down to open.

### Rotating Actuator Head

The actuator head may be rotated in 90° increments to create eight possible actuator engagement locations. To rotate the head, pull the holding clamp forward, rotate the head to the desired position, and push the holding clamp back in to lock.

## Mechanical Installation

All mounting hardware is supplied by the user. Fasteners must be of sufficient strength to guard against breakage. Use of permanent fasteners or locking hardware is recommended to prevent loosening or displacement of the actuator and the switch body. The mounting holes in the switch body and the actuator accept M5 screws (see dimensions, page 7).

Position the switch, with its actuator fully engaged, in the mounting location and mark the mounting holes. Drill the required holes and fasten the switch body and the actuator in place. After the mounting hardware is secure, check the actuator-switch engagement for misalignment and binding.

### IMPORTANT

1. A safety switch must be installed in a manner which discourages tampering or defeat. Mount each switch to prevent bypassing of the switching function at the terminal chamber.
2. A switch and its actuator must never be used as a mechanical stop.

# Machine Safety Switches – SI-LS83 and SI-LS100 Series

## Electrical Installation

### Access to the Wiring Chamber

The wiring chamber is accessed via the hinged door. See Figure 1. The SI-LS83 switches have a wire entrance of M16 x 1.5. The SI-LS100 models have a wire entrance of M20 x 1.5. All models come with an adaptor to convert to 1/2"–14 NPT. M16 x 1.5 and M20 x 1.5 cable glands are available on page 7.

### Connection to a Machine

As illustrated in Figure 2, a normally closed safety contact (i.e., a safety contact that is closed when the actuator is engaged) from each of two safety switches per interlocked guard must connect to a 2-channel safety module or safety interface in order to achieve a control reliable interface to the master stop control elements of a machine. Examples of appropriate safety modules include 2-channel emergency stop (E-stop) safety modules and gate monitor safety modules.

Two functions of the safety module or safety interface are:

1. to provide a means of monitoring the contacts of both safety switches for contact failure, and to prevent the machine from restarting if either switch fails; and
2. to provide a reset routine after closing the guard and returning the safety switch contacts to their closed position. This prevents the controlled machinery from restarting by simply reinserting the safety switch actuators. This necessary reset function is required by ANSI B11 and NFPA 79 machine safety standards.

Use only a positively driven, normally closed safety contact from each switch for connection to the safety module. *The normally open contact may be used for control functions that are not safety-related.* A typical use is to communicate switch status to a process controller. Refer to the installation instructions provided with the safety modules for more information regarding the interface of the safety module to the machine stop control elements.

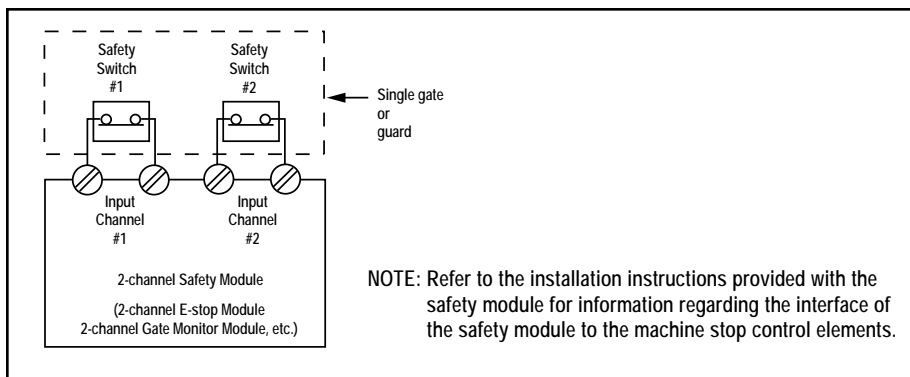

Figure 2. Connect two redundant safety switches per interlock guard to an appropriate 2-channel input safety module.



### WARNING . . .

It must not be possible for personnel to reach any hazard point through an opened guard (or any opening) before hazardous machine motion has completely stopped. Please reference OSHA CFR 1910.217 and ANSI B11 standards (see page 2) for information on determining safety distances and safe opening sizes for your guarding devices.



### CAUTION . . .

#### Electrical Installation

Two safety switches must be used for each interlock guard to achieve control reliability or Safety Category 4 (per ISO 13849-1, EN 954-1) of a machine stop circuit. Use of only one safety switch per interlock guard is not recommended.

In addition, normally closed safety contacts from each of the two safety switches should be connected to the two separate inputs of a 2-channel safety module or safety interface, as illustrated in Figure 2. This is required to provide monitoring for safety switch contact failure, and to provide the necessary reset routine, as required by IEC 60204-1 and NFPA 79 machine safety standards.



### WARNING . . . Series Connection of Safety Interlock Switches

Monitoring multiple guards with a series connection of multiple safety interlock switches is not a Safety Category 4 Application (per ISO 13849-1, EN 954-1). A single failure may be masked or not detected at all. When such a configuration is used, procedures must be performed regularly to verify proper operation of each switch.

# Machine Safety Switches – SI-LS83 and SI-LS100 Series

---

## Periodic Checks

We recommend that safety switches be checked at each shift change or machine setup by a *designated person* (see below) for:

1. Breakage of the switch body or actuator,
2. Good alignment and full engagement of the actuator with the receptor,
3. Confirmation that the safety switch is not being used as an end stop,
4. Loosening of the switch or actuator mounting hardware, and
5. Verification that it is not possible to reach any hazard point through an opened guard (or any opening) before hazardous machine motion has completely stopped.

In addition, we recommend that a *qualified person* check for the following on a periodic schedule determined by the user based upon the severity of the operating environment and the frequency of switch actuations:

1. Check the wiring chamber for signs of contamination.
2. Check the contacts for signs of deterioration or damage.
3. Inspect the electrical wiring for continuity and damage.
4. Verify that wiring conforms to the instructions on pages 3 and 4 of this data sheet.

A *designated person* is identified in writing by the employer as being appropriately trained to perform a specified checkout procedure. A *qualified person* possesses a recognized degree or certificate or has extensive knowledge, training, and experience to be able to solve problems relating to the safety switch installation (ANSI B30.2).

## Repairs



**Do not attempt any repairs to the switch. It contains no field-replaceable components. Return the switch to the factory for warranty repair or replacement.**

If it ever becomes necessary to return a switch to the factory, please do the following:

1. Contact the Banner applications engineering department at the number or address listed on the front cover. They will attempt to troubleshoot the system from your description of the problem. If they conclude that a component is defective, they will issue an RMA (Return Merchandise Authorization) number for your paperwork, and give you the proper shipping address.
2. Pack the switch carefully. Damage which occurs in shipping is not covered by warranty.

# Machine Safety Switches – SI-LS83 and SI-LS100 Series

## Specifications

Contact Rating	10A @ 24V ac, 10A @ 110V ac, 6A @ 230V ac; 6A @ 24V dc 2.5 kV max. transient tolerance NEMA A300 P300		
European Rating	Utilization categories: AC15 and DC13 (IEC 60947-5-1)	40-60 Hz	
	Switches with 1 and 2 contact pairs: $U_i = 500V$ ac $I_{th} = 10$ A	$\begin{array}{ c } \hline U_e \\ \hline V \\ \hline 24 \\ \hline 110 \\ \hline 230 \\ \hline \end{array}$	$\begin{array}{ c } \hline I_e/AC-15 \\ \hline A \\ \hline 10 \\ \hline 10 \\ \hline 6 \\ \hline \end{array}$
	Switches with 3 contact pairs: $U_i = 400V$ ac $I_{th} = 5$ A	$\begin{array}{ c } \hline I_e/DC-13 \\ \hline A \\ \hline 6 \\ \hline 1 \\ \hline 0.4 \\ \hline \end{array}$	
Contact Material	Silver-nickel alloy		
Maximum Switching Speed	30 operations per minute		
Maximum Actuator Speed	1 m/second (39"/second)		
Minimum Actuator Engagement Radius	In-line actuators: 150 mm (6") Flexible actuators: 50 mm (2") in all directions		
Actuator Extraction Force	12 Newtons (2.6 lbf)		
Short Circuit Protection	6 amp Slow Blow, 10 amp Fast Blow. Recommended external fusing or overload protection.		
Mechanical Life	1 million operations		
Wire Connections	Stranded and solid: 20 AWG (0.5 mm <sup>2</sup> ) to 18 AWG (1.0 mm <sup>2</sup> ) for one wire Stranded: 20 AWG (0.5 mm <sup>2</sup> ) to 18 AWG (1.0 mm <sup>2</sup> ) for two wires		
Cable Entry	SI-LS83 models: M16 x 1.5 threaded entrance SI-LS100 models: M20 x 1.5 threaded entrance Adapter supplied with each switch to convert to 1/2"-14 NPT threaded entrance.		
Construction	Glass fiber-reinforced polyamide thermoplastic housing; UL 94-V0 rating		
Environmental Rating	IEC IP65 NOTE: Addition of a No. 3 x 1/4" screw (max) to the wiring access door increases sealing to IEC IP67, NEMA 4X		
Operating Conditions	Temperature: -30° to +80° C (-22° to +176° F)		
Weight	SI-LS83 models: 0.12 kg (0.26 lb) SI-LS100 models: 0.13 kg (0.29 lb)		
Certifications	  		

# Machine Safety Switches – SI-LS83 and SI-LS100 Series

## Dimensions

Model SI-LS-100F Interlock Body

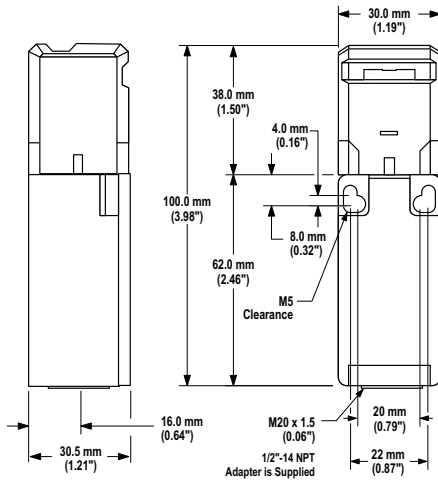

Model SI-LS-83.. Interlock Body

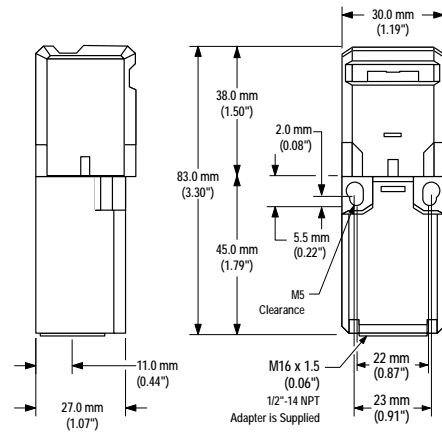

Model SI-QS-SSA-3 Right-Angle Actuator

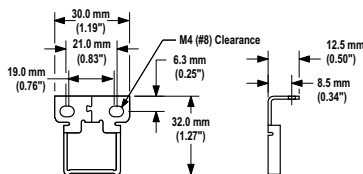

Switch and Actuator

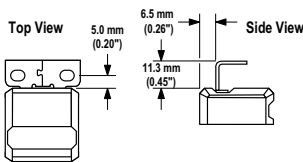

Model SI-QS-SSA-2 In-line Actuator

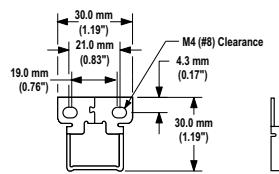

Switch and Actuator

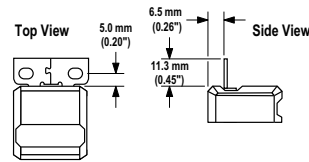

Model SI-QS-SSU Flexible Actuator

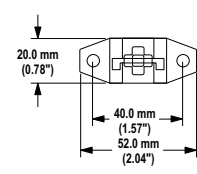

Switch and Actuator

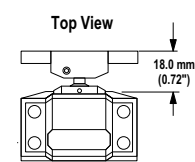

## Accessories

### Cable Glands

Size	Model	Used with Switch Models	For Cable Diameters	Dimensions
M16 x 1.5 Plastic	SI-QS-CGM16	SI-LS83	3.0 to 8.0 mm (0.12" to 0.31")	
M20 x 1.5 Plastic	SI-QS-CGM20	SI-LS100	5.0 to 12.0 mm (0.20" to 0.47")	

# Machine Safety Switches – SI-LS83 and SI-LS100 Series



## Accessories

### Conduit Adapters

Size	Model	Used with Switch Models	Thread Conversion	Dimensions
½"-14 NPT Plastic	SI-QS-M16	SI-LS83	M16 x 1.5 to ½"-14 NPT	
½"-14 NPT Plastic	SI-QS-M20	SI-LS100	M20 x 1.5 to ½"-14 NPT	

NOTE: One conduit adapter is supplied with each switch.

### Replacement Actuators

Type	Model	Application
In-line  SI-QS-SSA-2 SI-QS-SSA-3	SI-QS-SSA-2 SI-QS-SSA-3	For doors or covers with a radius of 150 mm (6"), or greater
Flexible 	SI-QS-SSU	For hinged doors with a radius of 50 mm (2") or greater. Flexes in four directions. The actuator is die-cast steel.
Adapter Plate 	SI-QS-SSUA	Clear acrylic adapter plate used to retrofit SI-QS-SSU to older flexible actuators SI-QS-HMA and SI-QS-VMA.



#### WARNING . . .

Spare actuators must NEVER be used to bypass or otherwise defeat the protective function of a safety switch. To do so may create an unsafe situation which could lead to serious injury or death.



**WARRANTY:** Banner Engineering Corp. warrants its products to be free from defects for one year. Banner Engineering Corp. will repair or replace, free of charge, any product of its manufacture found to be defective at the time it is returned to the factory during the warranty period. This warranty does not cover damage or liability for the improper application of Banner products. This warranty is in lieu of any other warranty either expressed or implied.