

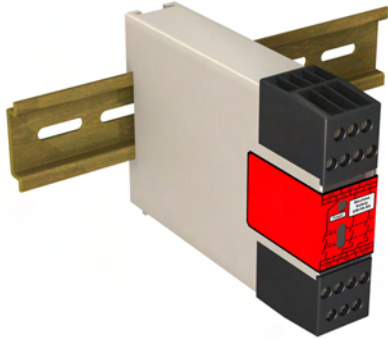

UM-FA-..A Series Universal Input Safety Modules

For 24V ac/dc operation, solid-state or relay inputs

Original Instructions



- **Monitors a wide variety of safety and non-safety input devices:**
 - Optical-based safeguarding devices, such as Safety Laser Scanners
 - Positive-opening safety switches used for guard interlocking
 - Emergency-stop devices, such as palm buttons and rope/cable pulls
 - Standard sensors for non-safety applications, such as photoelectric monitoring position or end-of-travel.
- **The safety inputs can monitor:**
 - +24V dc solid-state (PNP) outputs in single-channel or dual-channel hookup,
 - +24V dc source that is switched by hard/relay contacts in single-channel or dual-channel hookup, or
 - Hard/relay contacts in a dual-channel hookup using terminals S11-S12 and S21-S22
- **UM-FA-9A:** Three normally open (N.O.) output switching channels for connection to control-reliable power interrupt circuits
- **UM-FA-11A:** Two normally open (N.O.) and one normally closed (N.C.) output switching channels for connection to control-reliable power interrupt circuits
- Automatic reset or monitored manual reset, depending on hookup
- Design complies with standards ANSI B11.19, UL991, ISO 13850 (EN418), and ISO 13849-1 (EN954-1) (Safety Category 4)
- Safety Integrity Level (SIL) 3 (IEC 61508/62061)
- Performance level (PL) e (ISO 13849-1)
- For use in functional stop category 0 applications per ANSI NFPA 79 and IEC/EN 60204-1
- Plug-in terminal blocks
- 24V ac/dc operation

Models	Output Switching Channels	Safety Output Contact Rating
UM-FA-9A	3 normally open (N.O.)	6A
UM-FA-11A	2 normally open (N.O.), and 1 normally closed (N.C.)	7A

⚠ WARNING . . . Not a Point-of-Operation Guarding Device

This Safety Module is not a point-of-operation guarding device, as defined by OSHA regulations. It is necessary to install point-of-operation guarding devices, such as safety light curtains and/or hard guards, to protect personnel from hazardous machinery. **Failure to install point-of-operation guards on hazardous machinery can result in a dangerous condition which could lead to serious injury or death.**

Important ... read this before proceeding!

The user is responsible for satisfying all local, state, and national laws, rules, codes, and regulations relating to the use of this product and its application. Banner Engineering Corp. has made every effort to provide complete application, installation, operation, and maintenance instructions. Please direct any questions regarding the use or installation of this product to the factory applications department at the telephone numbers or address shown on back cover.

The user is responsible for making sure that all machine operators, maintenance personnel, electricians, and supervisors are thoroughly familiar with and understand all instructions regarding the installation, maintenance, and use of this product, and with the machinery it controls. The user and any personnel involved with the installation and use of this product must be thoroughly familiar with all applicable standards, some of which are listed below. Banner Engineering Corp. makes no claim regarding a specific recommendation of any organization, the accuracy or effectiveness of any information provided, or the appropriateness of the provided information for a specific application.

Applicable U.S. Standards	Applicable International Standards
<p>ANSI B11 Standards for Machine Tools Contact: Safety Director, AMT – The Association for Manufacturing Technology, 7901 Westpark Drive, McLean, VA 22102, Tel.: 703-893-2900</p>	<p>ISO 12100-1 (EN292-1) Safety of Machinery – Basic Concepts, General Principles for Design, Part 1: Basic Terminology, Methodology</p>
<p>ANSI NFPA79 Electrical Standard for Industrial Machinery Contact: National Fire Protection Association, 1 Batterymarch Park, P.O. Box 9101, Quincy, MA 02269-9101, Tel.: 800-344-3555</p>	<p>ISO 12100-2 (EN292-2) Safety of Machinery – Basic Concepts, General Principles for Design, Part 2: Technical Principals and Specifications</p>
<p>ANSI/RIA R15.06 Safety Requirements for Industrial Robots and Robot Systems Contact: Robotic Industries Association, 900 Victors Way, P.O. Box 3724, Ann Arbor, MI 48106, Tel.: 734-994-6088</p>	<p>IEC 62061 Safety of Machinery – Functional Safety of Safety-Related Electrical, Electronic and Programmable Electronic Control Systems</p>
	<p>ISO 13849-1 (EN954-1) Safety of Machinery – Related Parts of Control Systems: Part 1 General Principles for Design</p>
	<p>Contact: Global Engineering Documents, 15 Inverness Way East, Englewood, CO 80112-5704, Tel.: 800-854-7179</p>

Certificate of Adequacy

This Safety Module data sheet (p/n 141249) satisfies the requirements of Machinery Directive 2006/42/EC, Section 1.7.4 — instructions.

Overview

The **UM-FA-..A** Universal Safety Module (or "Safety Module" or "Module" in this document) is used to increase the control reliability of a circuit. As shown in Figures 4, 5, 6, and 7, the Safety Module is designed to monitor a 1-channel or 2-channel safety switch (e.g., E-stop or safety gate switch) or a 1-channel or 2-channel PNP output from devices such as a sensor or a safety laser scanner. (A 2-channel E-stop switch has two electrically isolated contacts.)

Safety Circuit Integrity and ISO 13849-1 Safety Circuit Principles

Safety circuits involve the safety-related functions of a machine that minimize the level of risk of harm. These safety-related functions can prevent initiation, or they can stop or remove a hazard. The failure of a safety-related function or its associated safety circuit usually results in an increased risk of harm.

The integrity of a safety circuit depends on several factors, including fault tolerance, risk reduction, reliable and well-tried components, well-tried safety principles, and other design considerations.

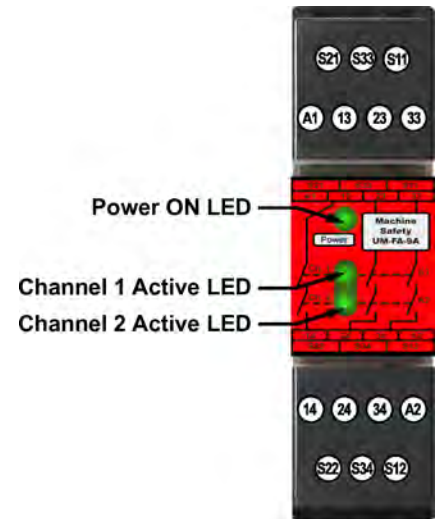

Figure 1: Features

Depending on the level of risk associated with the machine or its operation, an appropriate level of safety circuit performance (i.e., integrity) must be incorporated into its design. Standards that detail safety performance levels include ANSI/RIA R15.06 Industrial Robots, ANSI B11 Machine Tools, OSHA 29CFR1910.217 Mechanical Power Presses, and ISO 13849-1 (EN954-1) Safety-Related Parts of a Control System.

Safety Circuit Integrity Levels

Safety circuits in International and European standards have been segmented into categories, depending on their ability to maintain their integrity in the event of a failure. The most recognized standard that details safety circuit integrity levels is ISO 13849-1 (EN954-1), which establishes five levels: Categories B, 1, 2, 3, and the most stringent, Category 4.

In the United States, the typical level of safety circuit integrity has been called "control reliability." Control reliability typically incorporates redundant control and self-checking circuitry and has been loosely equated to ISO 13849-1 Categories 3 and 4 (see CSA Z432 and ANSI B11.TR4).

If the requirements described by ISO 13849-1 are to be implemented, a risk assessment must first be performed to determine the appropriate category, in order to ensure that the expected risk reduction is achieved. This risk assessment must also take into account national regulations, such as U.S. control reliability or European "C" level standards, to ensure that the minimum level of performance that has been mandated is complied with.

Fault Exclusion

An important concept within the category requirements of ISO 13849-1 is the "probability of the occurrence of the failure," which can be decreased using a technique termed "fault exclusion." The rationale assumes that the possibility of certain well-defined failure(s) can be reduced to a point where the resulting fault(s) can be, for the most part, disregarded-that is, "excluded."

Fault exclusion is a tool a designer can use during the development of the safety-related part of the control system and the risk assessment process. Fault exclusion allows the designer to design out the possibility of various failures and justify it through the risk assessment process to meet the intent requirements of Category 2, 3 or 4. See ISO 13849-1/-2 for further information.

⚠ WARNING . . . Safety Categories

The level of safety circuit integrity can be greatly impacted by the design and installation of the safety devices and the means of interfacing of those devices. **A risk assessment must be performed to determine the appropriate safety circuit integrity level or safety category as described by ISO 13849-1 (EN 954-1) to ensure that the expected risk reduction is achieved and that all relevant regulations and standards are complied with.**

Monitoring of Safety Devices

Requirements vary widely for the level of control reliability or safety category per ISO 13849-1 (EN954-1) in safety applications. While Banner Engineering always recommends the highest level of safety in any application, it is the responsibility of the user to safely install, operate and maintain each safety system and comply with all relevant laws and regulations.

While only three applications are listed in this document, the Module can monitor a variety of devices as long as the input requirements are complied with (see Electrical Installation and Specifications). **The UM-FA-..A Module does not have 500 ms simultaneity between inputs and thus can not be used for monitoring a two-hand control.** In all cases, the safety performance (integrity) must reduce the risk from identified hazards as determined by the machine's risk assessment.

⚠ WARNING . . . Incomplete Information

Many installation considerations necessary to properly applying these devices are not covered by this document. **Refer to the appropriate device installation instructions to ensure the safe application of the device.**

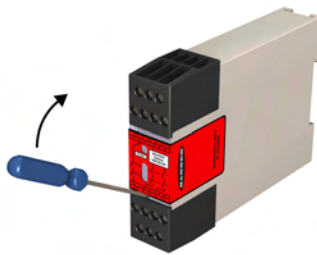

Figure 2: Accessing the DIP switches

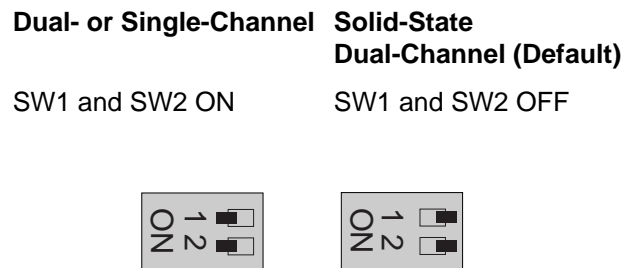

Figure 3: DIP switch settings

Indicators and Adjustments

The Safety Module has indicators for input power and output relay contact status (K1 and K2); see Figure 1. There are no adjustments and no user-serviceable parts.

The Safety Module can monitor dry contacts as well as solid state PNP outputs from sensors or light screens, either in single-channel or dual-channel mode. To select between contact inputs and solid-state inputs, set two DIP switches (under the lower terminal block) to the appropriate settings (see Figures). The factory default setting is for solid-state input mode (both switches OFF).

Input Device Requirements

Optical Sensors: The safety inputs may be used to monitor optical-based devices that use light as a means of detection. These devices include safety light screens (curtains), safety laser scanners, and multiple/single beam devices (grids/points).

The design and installation of the optical safeguarding device should comply with ANSI B11.19, IEC61496 (all parts), and other applicable standards. Optical safety devices must be placed at an appropriate safety distance (separation distance) from the safeguarded hazard. Because these devices vary, it is not practical to list specific calculations

here. Refer to the applicable standards and to manufacturer documentation specific to your device for the appropriate calculations and for complete installation information (such as AG4 installation manual p/n 144924).

Interlocked Guards (Gates): The safety inputs can be interfaced with positive-opening safety switches to monitor the position of an interlock guard or gate. Each switch must provide electrically isolated contacts: at minimum, one normally closed (N.C.) contact from each individually mounted switch. The contacts must be of "positive-opening" (direct-opening) design, as described by IEC 60947- 5-1, with one or more normally closed contacts rated for safety. In addition, the switches must be mounted in a "positive mode," to move/disengage the actuator from its home position and open the normally closed contact when the guard opens.

In higher levels of safety performance, the design of a dual-channel coded magnetic switch typically uses complementary switching, in which one channel is open and one channel is closed at all times. **The inputs of the UM-FA-..A do not support complementary switching, and thus should not be used with coded magnetic safety switches.**

The design and installation of the interlocked guard and the safety switches should comply with ANSI B11.19, ISO14119, and other applicable standards. See the device manufacturer installation instructions for complete information (such as **GM-FA-10J** p/n 60998, **SI-LS83/-LS100** p/n 59622, or **SI-HG63** p/n 129465 data sheets).

Emergency-Stop Push Buttons and Rope/Cable Pull Switches:

The safety inputs can be interfaced with positive-opening switches to monitor an emergency-stop (E-stop) push button or rope/cable pull. The switch must provide one or two contacts for safety which are closed when the switch is armed. Once activated, the E-stop switch must open all its safety-rated contacts, and must require a deliberate action (such as twisting, pulling, or unlocking) to return to the closed-contact, armed position. The switch must be a "positive-opening" (or direct-opening) type, as described by IEC 60947-5-1.

Standards ANSI NFPA 79, IEC/EN 60204-1, and ISO 13850 specify additional emergency stop switch device requirements, including the following:

- Emergency-stop push buttons shall be located at each operator control station and at other operating stations where emergency shutdown is required.
- Stop and emergency-stop push buttons shall be continuously operable and readily accessible from all control and operating stations where located. **Do not mute or bypass E-stop buttons or rope/cable pulls.**
- Actuators of emergency-stop devices shall be colored red. The background immediately around the device actuator shall be colored yellow (where possible). The actuator of a push-button-operated device shall be of the palm or mushroom-head type.
- The emergency-stop actuator shall be a self-latching type.

For Rope/Cable Pull installations only:

- The wire rope should be easily accessible and visible along its entire length. Markers or flags may be fixed on the rope to increase its visibility.
- Mounting points, including support points, must be rigid.
- The rope should be free of friction at all supports. Pulleys are recommended.

Some applications may have additional requirements; **comply with all relevant regulations.** See the device manufacturer installation instructions for complete information (such as **ES-..A-5A** p/n 122365, **SSA-EB...-** p/n 111880, or **RP-RM83F..** p/n 141245 data sheets).

WARNING . . . Emergency Stop Functions

Do not mute or bypass any emergency stop device. ANSI NFPA79 and IEC/EN 60204-1 require that the emergency stop function remain active at all times. **Muting or bypassing the Safety Outputs will render the emergency stop function ineffective.**

⚠ WARNING . . . Multiple E-Stop Switches

Whenever two or more emergency-stop switches are connected to the same Module:

- **Contacts of the corresponding pole of each switch must be connected together in series. Never connect the contacts of multiple emergency-stop switches in parallel to one Module.** Such a parallel connection defeats the switch contact monitoring ability of the Module and creates an unsafe condition which could result in serious injury or death.
- **Each switch must be individually actuated (engaged), then re-armed and the Module reset.** This allows the Module to check each switch and its wiring to detect faults.

Failure to test each switch individually in this manner could result in undetected faults and create an unsafe condition which could result in serious injury or death. This check must be performed during periodic checkouts.

Mechanical Installation

The Safety Module must be installed inside an enclosure. It is not designed for exposed wiring. **It is the user's responsibility to house the Safety Module in an enclosure with NEMA 3 (IEC IP54) rating, or better.**

The Safety Module mounts directly to standard 35 mm DIN rail; see Dimensions.

Heat Dissipation Considerations

For reliable operation, ensure that the operating specifications are not exceeded. The enclosure must provide adequate heat dissipation, so that the air closely surrounding the Module does not exceed the maximum operating temperature stated in the Specifications. Methods to reduce heat build-up include venting, forced airflow (e.g., exhaust fans), adequate enclosure exterior surface area, and spacing between modules and other sources of heat.

Electrical Installation

It is not possible to give exact wiring instructions for a Safety Module which interfaces to a multitude of machine control configurations. The following guidelines are general in nature.

The Safety Module has no delay function. Its output relay contacts open within 25 milliseconds after a safety input opens. This classifies the Safety Module as functional stop "Category 0", as defined by NFPA 79 and IEC/EN 60204-1.

The safety inputs can be connected to:

- +24V dc solid-state (PNP) outputs in single-channel or dual-channel hookup configuration,
- +24V dc source that is switched by hard/relay contacts in single-channel or dual-channel hookup configuration, or
- Hard/relay contacts in a dual-channel hookup configuration using terminals S11-S12 and S21-S22.

The UM Safety Module must be configured (via DIP switch) for the appropriate hookup in order to operate properly. When using devices with redundant solid-state safety outputs (such as the **AG4** Safety Laser Scanner OSSDs) or redundant hard contacts switching a +24V dc source, **both the DIP switches must be set to the "OFF" position** (default position, see Figure 3). This setting is for solid-state dual-channel hookup using terminals S11-S12 and S21-S22 as described in Figure 5.

To configure the Module for dual-channel hookup to monitor a device with redundant hard contacts (such as an emergency-stop button), **set both the DIP switches to the "ON" position**. This setting is for dual-channel hookup using terminals S11-S12 and S21-S22 as described in Figure 4, or when the dual-channel input is not used (i.e., is jumpered) in single-channel hookup configuration as described in Figures 6 and 7.

Safety Input Device Hookup Options

The operation of all dual-channel hookup options is concurrent, meaning that input channel 1 and input channel 2 must be in the same state in both the STOP and RUN condition, but with no simultaneity (i.e. timing) requirement between the channels.

The **dual-channel hookup configuration** is able to detect certain failures and faults, such as short circuits, that could result in a loss of the safety function. Once such a failure or fault is detected, the Safety Module will turn OFF (open) its safety outputs until the problem is fixed. This circuit (Figure 4) can meet ISO 13849-1 Category 2, 3, or 4 requirements, depending on the safety rating and the installation of the safety input device. This circuit can detect a short circuit between channels or to another source of power, at a minimum, when the device is actuated.

The **solid-state dual-channel hookup configuration** can not detect short circuits between input channels or to secondary sources of +24V dc. To achieve higher levels of safety performance, the safety device that is connected to input channels 1 and 2 must be capable of detecting these short circuits and properly responding by turning both channels OFF.

This circuit (Figure 5) can meet ISO 13849-1 Category 2, 3, or 4 requirements depending on the safety rating, installation, and the fault detection (e.g., short circuit) capabilities of the safety input device. If short circuit detection is not provided, the circuit can meet only Category 3. A single device with redundant outputs that can fail in such a manner to lose the safety function, such as a single safety interlocking switch, can typically meet only a Category 2. See below for means to eliminate or minimize the possibility of failures and faults that could result in the loss of the safety function(s).

The **single-channel hookup configuration** can not detect short circuits to secondary sources of +24V dc or detect the loss of the switching function of the safety input device (i.e., it is not redundant) and thus this circuit (Figures 6 and 7) typically can meet only ISO 13849-1 Category 2.

It is recommended that in all circumstances the installation of the **UM-FA-..A** Safety Module and its associated safety input devices are installed to eliminate or minimize the possibility of failures and faults that could result in the loss of the safety function(s).

Methods to eliminate or minimize the possibility of these failures include, but are not limited to:

- Physically separating interconnecting control wires from each other and from secondary sources of power.
- Routing interconnecting control wires in separate conduit, runs, or channels.
- Locating all elements (modules, switches, and devices under control) within one control panel, adjacent to each other, and directly connected with short wires.
- Properly installing multi-conductor cabling and multiple wires through strain-relief fittings. (Over-tightening of a strain-relief can cause short circuits at that point.)
- Using positive-opening components as described by IEC 60947-5-1 that are installed and mounted in a positive mode.
- Periodically checking the functional integrity / safety function and training operators, maintenance personnel, and others associated with the operation of the machine to recognize and immediately correct such failures.

If you have any questions about your intended use, please contact a Banner applications engineer at the numbers listed on the last page.

 **CAUTION . . . Shock Hazard**

Always disconnect power from the Safety Module and all power from the machine being controlled before making any connections or replacing any component. Electrical installation and wiring must be made by qualified personnel and must comply with the NEC (National Electrical Code), ANSI NFPA79 or IEC 60204-1, and all applicable local standards and codes.

 **WARNING . . . Wiring of Arc Suppressors**

If arc suppressors are used, they MUST be installed as shown across the actuator coil of the Master Stop Control Elements (MSC1 to MSC3). **NEVER install suppressors directly across the output contacts of the Safety Module.** It is possible for suppressors to fail as a short circuit. If installed directly across the output contacts of the Safety Module, **a short-circuited suppressor will create an unsafe condition which could result in serious injury or death.**

 **WARNING . . . Interfacing MSCs**

NEVER wire an intermediate device(s) (e.g., PLC, PES, PC), between the Safety Module outputs and the master stop control element (MSCE) it switches in such a manner that in the event of a failure there is the loss of the safety stop command, OR in such a manner that the safety function can be suspended, overridden, or defeated, unless accomplished with the same or greater degree of safety. Whenever forced-guided, mechanically linked relays are added as intermediate switching devices, a normally closed forced-guided monitor contact from each relay must be added to the series feedback loop between Safety Module terminals S31 and S32.

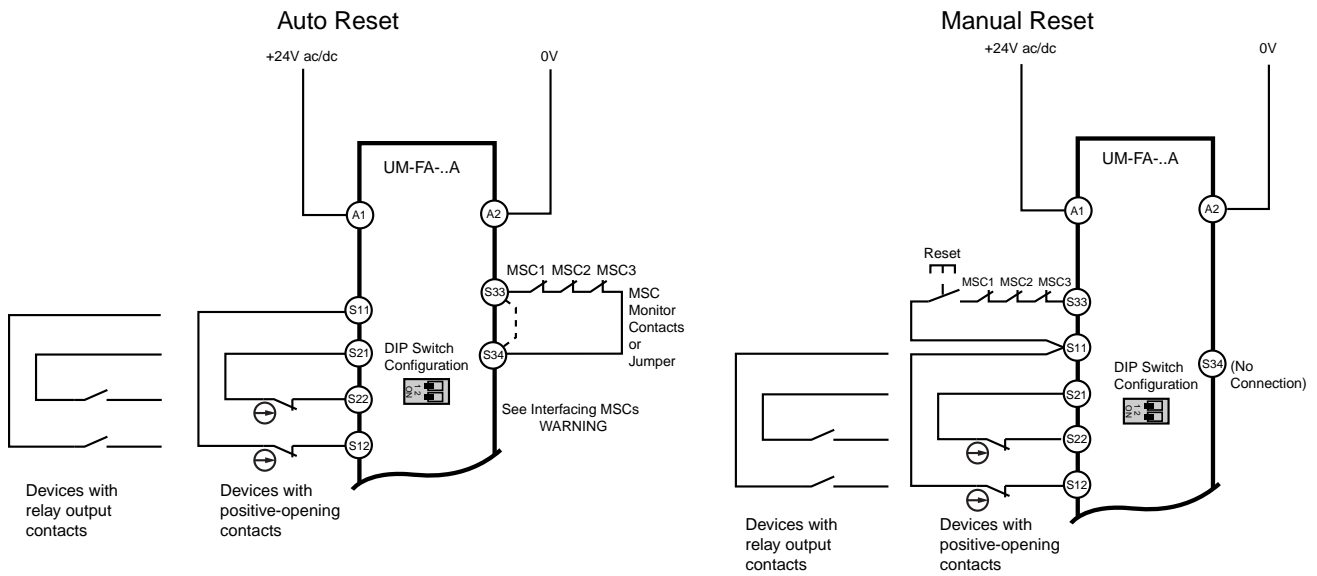

Figure 4: Dual-channel hookup configuration, devices with hard contacts

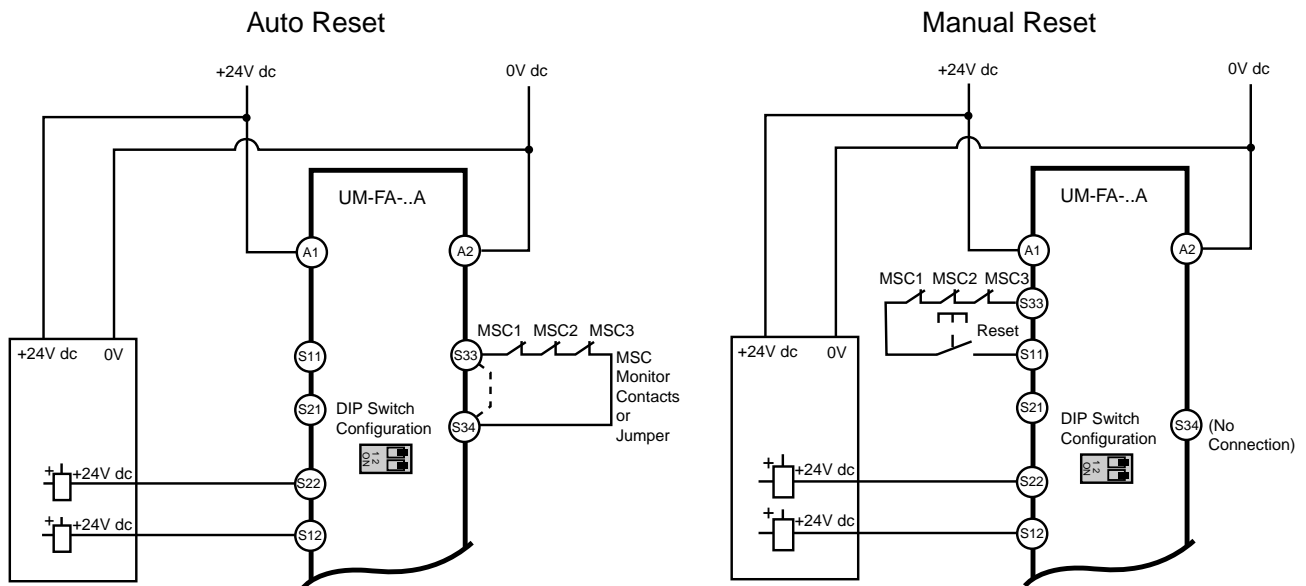

Figure 5: Dual-channel hookup configuration, solid-state devices (+24V dc supply only)

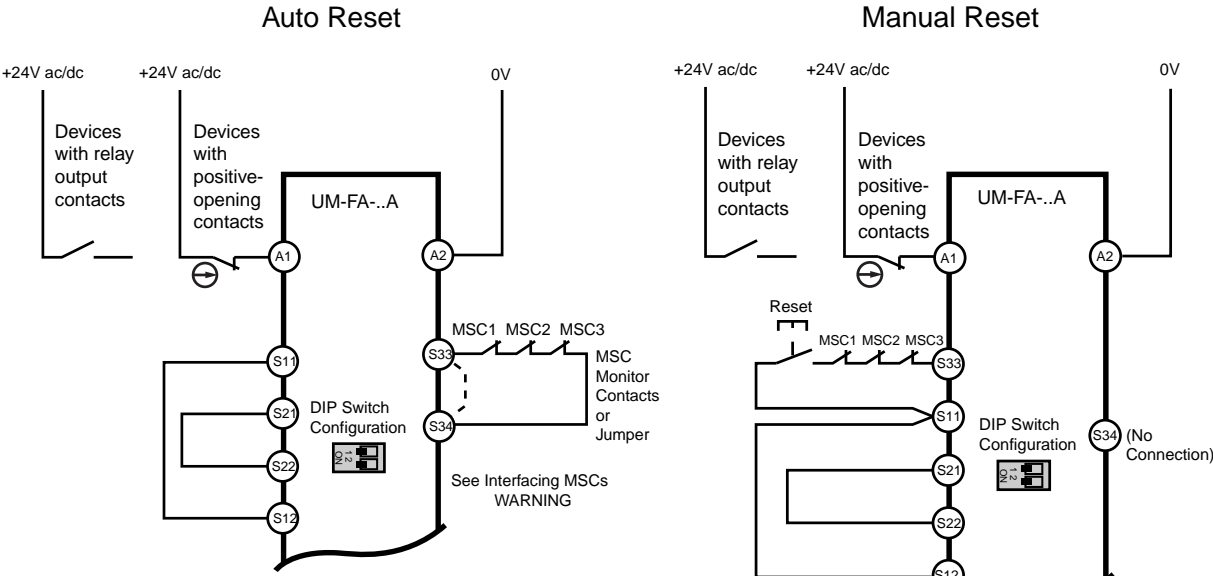

Figure 6: Single-channel hookup configuration, devices with hard contacts

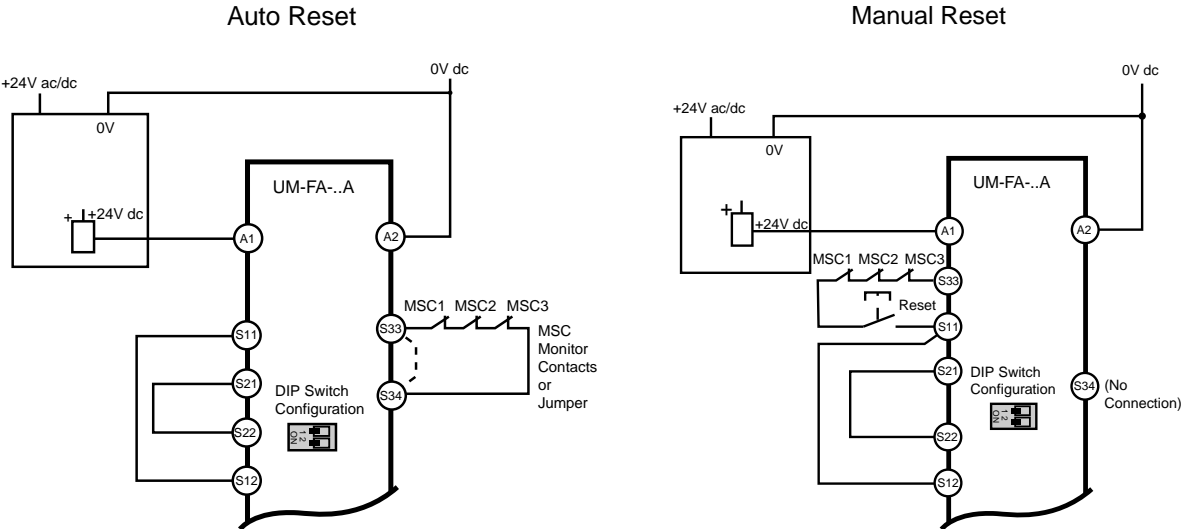

Figure 7: Single-channel hookup configuration, solid-state devices

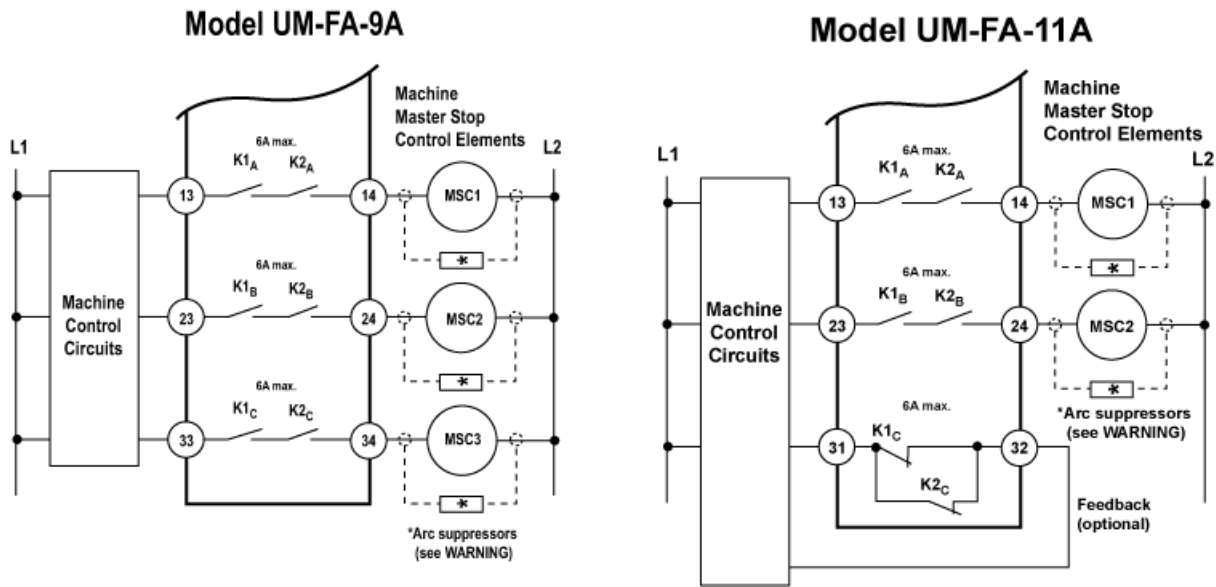

Figure 8: Machine control circuit connections

Connection of Reset Switch

The reset circuit switch can be any mechanical switch, such as a normally open momentary switch, or a two-position key switch. The reset switch must be capable of reliably switching 12V dc at 10 to 20 milliamps. As shown in Figures 4, 5, 6, and 7, the reset switch connects between terminals S11 and S33 of the Safety Module.

The reset switch must be located outside of – and not be accessible from – the area of dangerous motion, and must be positioned so that any area of dangerous motion may be observed by the switch operator during the reset procedure. See warning, Reset Switch Location.

⚠ WARNING . . . Reset Switch Location

The reset switch must be accessible only from outside, and in full view of, the hazardous area. Reset switches must also be out of reach from within the safeguarded space, and must be protected against unauthorized or inadvertent operation (e.g., through the use of rings or guards). If any areas are not visible from the reset switch(es), additional means of safeguarding must be provided.

Failure to do so could result in serious bodily injury or death.

Automatic Reset Mode

The Safety Module may be used also with automatic reset. If no MSC-monitor contacts are monitored, a jumper must be installed between terminals S33 and S34 (see Figures 4, 5, 6, and 7). The Safety Module will reset (and the outputs energize) as soon as the inputs return to an ON (or "closed-contact") state.

The automatic reset mode is useful for some automated processes. **However, if automatic reset is used, it is necessary to provide an alternate means of preventing resumption of hazardous machine motion, until an alternate reset procedure is performed.** The alternate procedure must include a reset/restart switch, located outside the area of dangerous motion, which is positioned so that any area of dangerous motion may be observed by the switch operator during the reset procedure. See Warning below.

⚠ WARNING . . . Reset Routine Required

U.S. and international standards require that a reset routine be performed after clearing the cause of a stop condition (e.g., arming an E-stop button, closing an interlocked guard, removing an interruption of a sensing field, etc.). **Allowing the machine to restart without actuating the normal start command/device can create an unsafe condition which could result in serious injury or death.**

NOTE: The minimum amount of time required for the Module to be in a STOP or OFF condition is 250 ms. This "recovery time" (OFF-state) is required for the internal circuitry of the Safety Module to normalize, allowing a reliable reset to occur. A lockout will occur if the Module is cycled too quickly. To clear the lockout, re-cycle the Module, meeting the minimum OFF time requirements.

Connection to the Machine to be Controlled

The machine control hookup diagrams show a generic connection of the Safety Module's redundant output circuits to the MSCs. An MSC is defined as an electrically powered device, external to the Safety Module, which stops the machinery being controlled by immediately removing electrical power to the machine and (when necessary) by applying braking to dangerous motion. This stopping action is accomplished by removing power to the actuator of either MSC.

External Device Monitoring

To satisfy the requirements of Control Reliability (OSHA and ANSI) Category 3 and 4 of ISO 13849-1 (EN 954-1), the master stop control elements (MSCs) must each offer a normally closed, forced-guided (mechanically linked) monitor contact. Connect one normally closed monitor contact from each master stop control element in series to S33-S34 in Auto Reset mode and to S11-S33 in Manual Reset mode (see Figures 4, 5, 6, and 7).

In operation, if one of the switching contacts of either MSC fails in the energized condition, the associated monitor contact will remain open. Therefore, it will not be possible to reset the Safety Module. If no MSC-monitor contacts are monitored, a jumper must be installed as shown on Figures 4, 5, 6, and 7. **It is the user's responsibility to ensure that any single failure will not result in a hazardous condition and will prevent a successive machine cycle.**

Overvoltage Category II and III Installations (EN 50178 and IEC 60664-1)

The Safety Module is rated for Overvoltage Category III when voltages of 1V to 150V ac/dc are applied to the output relay contacts. It is rated for Overvoltage Category II when voltages of 151V to 250V ac/dc are applied to the output relay contacts and no additional precautions are taken to attenuate possible overvoltage situations in the supply voltage. The Module can be used in an Overvoltage Category III environment (with voltages of 151V to 250V ac/dc) if care is taken either to reduce the level of electrical disturbances seen by the Module to Overvoltage Category II levels by installing surge suppressor devices (e.g., arc suppressors), or to install extra external insulation in order to isolate both the Safety Module and the user from the higher voltage levels of a Category III environment.

For Overvoltage Category III installations with output contact voltage 151V to 250V ac/dc applied to the output contact(s): the Safety Module may be used under the conditions of a higher overvoltage category where appropriate overvoltage reduction is provided. Appropriate methods include:

- An overvoltage protective device
- A transformer with isolated windings
- A distribution system with a multiplicity of branch circuits (capable of diverting energy of surges)
- A capacitance capable of absorbing energy of surges
- A resistance or similar damping device capable of dissipating the energy of surges

When switching inductive ac loads, it is good practice to protect the Safety Module outputs by installing appropriately-sized arc suppressors. However, if arc suppressors are used, they must be installed across the load being switched (e. g., across the coils of external safety relays), and never across the Safety Module's output contacts (see WARNING, Wiring of Arc Suppressors).

Initial Checkout Procedure



CAUTION . . . Disconnect Power Prior to Checkout

Before performing the initial checkout procedure, make certain all power is disconnected from the machine to be controlled.

Dangerous voltages may be present along the Safety Module wiring barriers whenever power to the machine control elements is ON. **Exercise extreme caution whenever machine control power is or may be present. Always disconnect power to the machine control elements before opening the enclosure that houses the Safety Module.**

1. Remove power from the machine control elements.
2. Ensure the safety device is in a STOP or "open-contact" state (e.g., actuate the E-stop switch to open its contacts).
3. Apply power to the Safety Module at terminals A1 and A2 (see Figures 4, 5, 6, and 7). Verify that only the Input Power indicator (Figure 1) is ON. If either input channel 1 (K1) or input channel 2 (K2) indicators are ON at this point, disconnect the input power and check all wiring. Return to step 2 after the cause of the problem has been corrected.
4. Reset or otherwise cause the safety device to reach an ON or "closed-contact" state (e.g., arm the E-stop switch to close its contacts).
5. **Automatic reset:** Ch1 (K1) and Ch2 (K2) indicators should come ON, and the safety output contacts should close.
Manual reset: From an open condition, close the reset switch for approximately ¼ second, and then re-open. The Ch1 (K1) and Ch2 (K2) indicators should both come ON steady at this time. If either indicator comes ON before the reset switch is opened, disconnect the input power and check all wiring. Return to step 2 after correcting the problem.
6. Cause the safety device to generate a STOP or "open-contact" state (e.g., actuate the E-stop switch to open its contacts). The Ch1 (K1) and Ch2 (K2) indicators should turn OFF simultaneously. If either indicator remains ON, disconnect the input power and check all wiring. Return to step 2 after the cause of the problem has been corrected.
7. **If more than one safety device is series-connected to the Safety Module, run the above checkout procedure individually for EACH device.**
8. Close and secure the enclosure in which the Safety Module is mounted. Apply power to the machine control elements and perform the Periodic Checkout Procedure.



WARNING . . . Multiple Safety Devices

When two or more safety devices are used, each device must be individually actuated, causing a STOP or open-contact condition, then reset/rearmed and the Safety Module reset (if using manual reset mode). This allows the monitoring circuits to check each device and its wiring to detect faults. Failure to test each device individually in this manner could result in undetected faults and create an unsafe condition which could result in serious injury or death.

Periodic Checkout Procedure

The functioning of the Safety Module and the device(s) connected to it must be verified on a regular periodic basis to ensure proper operation (see also the machine manufacturer's recommendations).

1. With the machine running, cause the safety device to generate a STOP or "open-contact" state (e.g., actuate the E-stop switch to open its contacts). Verify that the machine stops.
2. Reset or otherwise cause the safety device to reach an ON or "closed-contact" state. Verify that the machine does not restart.
3. **If using manual reset mode**, close and then open the reset switch within 3 seconds. Verify that the machine can be restarted by normal initiation.
4. **If more than one safety device is series-connected to the Safety Module, run the above checkout procedure individually for EACH device.**

Repairs

Do not attempt any repairs to the Safety Module. It contains no field-replaceable components. Return it to the factory for warranty repair or replacement.

Contact Banner Factory Application Engineering at the address or the numbers listed on the back page. They will attempt to troubleshoot the system from your description of the problem. If they conclude that a component is defective, they will issue a return merchandise authorization (RMA) number for your paperwork, and give you the proper shipping address.

Pack the Safety Module carefully. Damage which occurs in return shipping is not covered by warranty.

CAUTION . . . Abuse of Module After Failure

If an internal fault has occurred and the Module will not reset, **do not tap, strike, or otherwise attempt to correct the fault by a physical impact to the housing.** An internal relay may have failed in such a manner that its replacement is required.

If the Module is not immediately replaced or repaired, multiple simultaneous failures may accumulate such that the safety function can not be guaranteed.

Specifications

Category	Specification																				
Supply Voltage and Current	24V dc \pm 10% (SELV-rated supply according to EN IEC 60950, NEC Class 2) 24V ac \pm 10%, 50/60Hz (NEC Class 2-rated transformer) Power consumption: approx. 2W/2VA																				
Supply Protection Circuitry	Protected against transient voltages and reverse polarity																				
Overvoltage Category	Output relay contact voltage 1V to 150V ac/dc: Category III Output relay contact voltage 151V to 250V ac/dc: Category II (Category III, if appropriate overvoltage reduction is provided, as described on page 7.)																				
Pollution Degree	2																				
Output Configuration	<p>Model UM-FA-9A: 3 normally open (N.O.) output channels</p> <p>Model UM-FA-11A: 2 normally open (N.O.) output channels and 1 normally closed (N.C.) auxiliary output channel</p> <p>Each normally open output channel is a series connection of contacts from two forced-guided (mechanically linked) relays, K1-K2. The normally closed Aux. output channel of the UM-FA-11A is a parallel connection of contacts from two forced-guided relays, K1-K2.</p> <p>Contacts: AgNi, 5 μm gold-plated</p> <p>Low Current Rating: The 5 μm gold-plated contacts allow the switching of low current/low voltage. In these low-power applications, multiple contacts can also be switched in series (e.g., "dry switching"). To preserve the gold plating on the contacts, do not exceed the following max. values at any time:</p> <table style="width: 100%; border: none;"> <tr> <td style="width: 50%;">Min. voltage: 1V ac/dc</td> <td style="width: 50%;">Max. voltage: 60V</td> </tr> <tr> <td>Min. current: 5 mA ac/dc</td> <td>Max. current: 300 mA</td> </tr> <tr> <td>Min. power: 5 mW (5 mVA)</td> <td>Max. power: 7 W (7 VA)</td> </tr> </table> <p>High Current Rating: If higher loads must be switched through one or more of the contacts, the minimum and maximum values of the contact(s) changes to:</p> <table style="width: 100%; border: none;"> <tr> <td style="width: 50%;">Min. voltage: 15V ac/dc</td> <td style="width: 50%;">Max. voltage: 250V ac/dc</td> </tr> <tr> <td>Min. current: 30 mA ac/dc</td> <td>Max. current:</td> </tr> <tr> <td></td> <td style="padding-left: 40px;">UM-FA-9A: 6 A</td> </tr> <tr> <td></td> <td style="padding-left: 40px;">UM-FA-11A: 7 A</td> </tr> <tr> <td>Min. power: 0.45 W (0.45 VA)</td> <td>Max. power:</td> </tr> <tr> <td></td> <td style="padding-left: 40px;">UM-FA-9A: 200 W (1,500 VA)</td> </tr> <tr> <td></td> <td style="padding-left: 40px;">UM-FA-11A: 200 W (1,750 VA)</td> </tr> </table>	Min. voltage: 1V ac/dc	Max. voltage: 60V	Min. current: 5 mA ac/dc	Max. current: 300 mA	Min. power: 5 mW (5 mVA)	Max. power: 7 W (7 VA)	Min. voltage: 15V ac/dc	Max. voltage: 250V ac/dc	Min. current: 30 mA ac/dc	Max. current:		UM-FA-9A: 6 A		UM-FA-11A: 7 A	Min. power: 0.45 W (0.45 VA)	Max. power:		UM-FA-9A: 200 W (1,500 VA)		UM-FA-11A: 200 W (1,750 VA)
Min. voltage: 1V ac/dc	Max. voltage: 60V																				
Min. current: 5 mA ac/dc	Max. current: 300 mA																				
Min. power: 5 mW (5 mVA)	Max. power: 7 W (7 VA)																				
Min. voltage: 15V ac/dc	Max. voltage: 250V ac/dc																				
Min. current: 30 mA ac/dc	Max. current:																				
	UM-FA-9A: 6 A																				
	UM-FA-11A: 7 A																				
Min. power: 0.45 W (0.45 VA)	Max. power:																				
	UM-FA-9A: 200 W (1,500 VA)																				
	UM-FA-11A: 200 W (1,750 VA)																				

Category	Specification
	<p>Mechanical life: > 20,000,000 operations</p> <p>Electrical life (switching cycles of the output contacts, resistive load): 150,000 cycles @ 1,500 VA; 1,000,000 cycles @ 450 VA; 2,000,000 cycles @ 250 VA; 5,000,000 cycles @ 125 VA</p> <p>NOTE: Transient suppression is recommended when switching inductive loads. Install suppressors across load. Never install suppressors across output contacts (see Warning, Arc Suppressors).</p>
Output Response Time	25 milliseconds typical
Input Requirements	<p>Safety Input Switch</p> <p>2-Channel (contacts) hookup: 10 to 20 mA steady state @ 12V dc</p> <p>NOTE: Inputs are designed with a brief contact-cleaning current of 100 mA when initially closed.</p> <p>Solid-State Dual Channel hookup: 5 to 20 mA steady state @ 18 to 28V dc sourcing (PNP), < 2 mA leakage current</p> <p>Single-Channel hookup: 40 to 100 mA @ 24V ac/dc \pm 10%; 50/60 Hz</p> <p>Reset Switch: 20 mA @ 12V dc, hard contact only</p>
Minimum OFF-State Recovery Time	250 ms (When used with the AG4 Safety Laser Scanner, the "Restart delay time after PF release" must be configured for 280 ms or greater.)
Indicators	3 green LED indicators: Power ON, K1 energized, K2 energized
Construction	Polycarbonate housing. Rated NEMA 1, IEC IP40; Terminals IP20
Mounting	Mounts to standard 35 mm DIN rail track. Safety Module must be installed inside an enclosure rated NEMA 3 (IEC IP54), or better.
Vibration Resistance	10 to 55 Hz @ 0.35 mm displacement per IEC 60068-2-6
Operating Conditions	<p>Temperature: 0° to +50°C (+32° to 122°F)</p> <p>Max. Relative Humidity: 90% @ +50°C (non-condensing)</p>
Design Standards	Cat. 4 PL e per EN ISO 13849-1; SIL 3 per IEC 61508 and IEC 62061
Certifications	

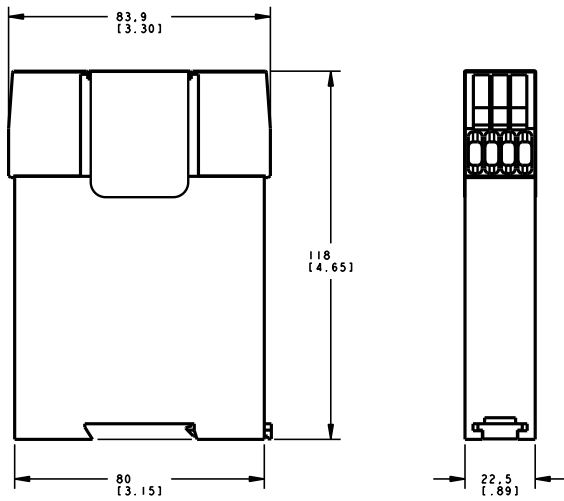

Figure 9: Dimensions

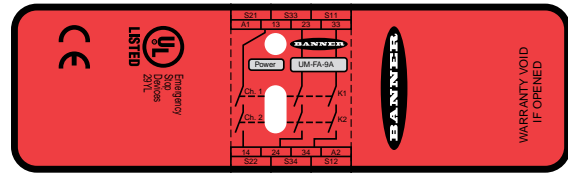

Figure 10: Product label (model UM-FA-9A shown)