





SMI912 Series sensor, with CI3RC2 current amplifier module (left) and intrinsic safety barrier (right)



## Features

- Offers economy, performance and reliability in a rugged housing
- Provides standard limit-switch mounting hole spacing
- Use with approved intrinsically safety barriers and Banner MAXI-AMP™ model CI3RC2 current trip point amplifier
- Certified for use in all Classes, Groups, and Divisions of hazardous locations as defined by Article 500 of the National Electrical Code when used with approved I.S. barriers
- Provides 10 to 30V dc supply voltage with NPN output
- Features a light- or dark-operate selection switch
- Available in opposed, polarized and non-polarized retroreflective, diffuse, convergent, and glass or plastic fiber optic sensing modes
- Ranges up to 60 m
- Integral 3-pin Mini-style QD fitting; QD cordset required, see page 9

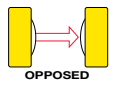
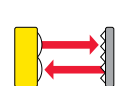
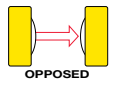
## Models

Sensing Mode		Model	Range	Voltage	Sensing Mode		Model	Range	Voltage
Long-Range Opposed	880 nm Infrared	SMI91EQD Emitter	60 m (200')	10 to 30V dc	Non-Polarized Retro†	650 nm Visible Red	SMI912LVQD	150 mm to 9 m (6" to 30')	10 to 30V dc
	 OPPOSED	SMI91RQD Receiver				 RETRO			
Short-Range Opposed	880 nm Infrared	SMI91ESRQD Emitter	3 m (10')		Polarized Retro†	650 nm Visible Red	SMI912LVAGQD	300 mm to 4.5 m (1' to 15')	
	 OPPOSED	SMI91RSRQD Receiver				 POLAR RETRO			

† Performance based on use of a model BRT-3 retroreflector (3" diameter). Actual sensing range may be more or less than specified, depending on the efficiency and reflective area of the retroreflector used.

Models continued on page 2





**⚠ WARNING . . . Not To Be Used for Personnel Protection**

Never use these products as sensing devices for personnel protection. Doing so could lead to serious injury or death. These sensors do NOT include the self-checking redundant circuitry necessary to allow their use in personnel safety applications. A sensor failure or malfunction can cause either an energized or de-energized sensor output condition. Consult your current Banner Safety Products catalog for safety products which meet OSHA, ANSI and IEC standards for personnel protection.

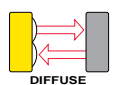
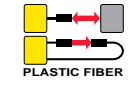

# VALU-BEAM® SMI912 Series – NAMUR

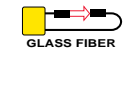
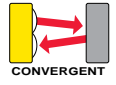
## Models, continued

Sensing Mode		Model	Range	Voltage	Sensing Mode		Model	Range	Voltage
Long-Range Diffuse	880 nm Infrared	SMI912DQD	760 mm (30")	10 to 30V dc	Plastic Fiber Optic	650 nm Visible Red	SMI912FPQD	See performance curves on page 5	10 to 30V dc
	 DIFFUSE					 PLASTIC FIBER			
Short-Range Diffuse	880 nm Infrared	SMI912DSRQD	380 mm (15")		Glass Fiber Optic	SMI912EFQD Emitter	SMI912RFQD Receiver	See performance curves on page 6	
	 DIFFUSE					 GLASS FIBER			
Convergent	650 nm Visible Red	SMI912CVQD	Focus at: 38 mm (1.5")		Glass Fiber Optic	880 nm Infrared	SMI912FQD	See performance curves on page 6	
	 CONVERGENT		Spot Size at Focus: 1.5 mm (0.06")			 GLASS FIBER			

## Overview

VALU-BEAM SMI912 Series sensors are designed for intrinsically safe operation in hazardous atmospheres. They are certified by Factory Mutual Research, CSA, and KEMA as being intrinsically safe when used with approved intrinsic safety barriers.

SMI912 Series sensors may be wired for either two- or three-wire current-sinking operation. In the three-wire hookup, which requires two intrinsic-safety barriers, the sink current is 15 mA. The two-wire hookup, which requires one barrier, sinks 10 mA (OFF state) and 20 mA (ON state).

SMI912 Series sensors feature rugged, encapsulated construction, along with adjustable sensitivity and switchable light or dark operate. They also include Banner's exclusive Alignment Indicating Device system, which lights an indicator LED whenever the sensor "sees" its modulated light source, and pulses at a rate proportional to the received light signal strength.

Intrinsic safety barriers and current trip point amplifier model CI3RC2 are also available (see pages 9 and 10).

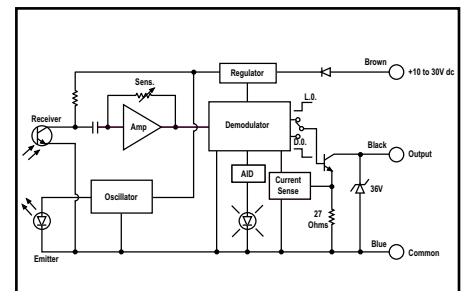

Figure 1. Functional schematic

## Installation Notes

### FM INSTALLATION

1. Barriers must be installed in accordance with manufacturer's instructions.
2. Barrier entity parameters must meet the following requirements:  
 $V_{oc}$  or  $V_t$     $V_{max}$     $C_a$     $C_i + C_{cable}$   
 $I_{sc}$  or  $I_t$     $I_{max}$     $L_a$     $L_i + L_{cable}$
3. Maximum non-hazardous area voltage must not exceed 250V.
4. For guidance on installation, see ANSI/ISA RP12.6, "Installation of Intrinsically Safe Instrument Systems for Hazardous (Classified) Locations."
5. The sensors are suitable for installation without barriers in Class I Div. 2 Groups A, B, C, D; Class II Div. 2 Group G; and Class III Div. 2, when installed in (or through the wall of) a suitable enclosure with provision for connection of rigid metal conduit per the National Electrical Code, as acceptable to the local inspection authority having jurisdiction.

### CSA INSTALLATION

1. Barriers must be installed in accordance with manufacturer's instructions.
2. Barrier entity parameters must meet the following requirements:  
 $V_{oc}$     $V_{max}$     $C_a$     $C_i + C_{cable}$   
 $I_{sc}$     $I_{max}$     $L_a$     $L_i + L_{cable}$
3. Maximum non-hazardous area voltage must not exceed 250V.
4. Install in accordance with Canadian Electrical Code, Part I.
5. The sensors are suitable for installation without barriers in Class I Div. 2 Groups A, B, C, D when installed in (or through the wall of) a suitable enclosure with provision for connection of rigid metal conduit per the Canadian Electrical Code, as acceptable to the local inspection authority having jurisdiction.

In Div. 2 installations (without barriers), observe warning at left.

6. If barriers with Volt/Ohm parameters are used, the following parameters shall apply:

#### One Single-Channel Barrier Systems

- one 28 V (max), 300 (min)

#### Two Single-Channel Barrier or One Dual-Channel Systems

- two 28 V (max), 600 (min)
- one 28 V (max), 300 (min) and one 10 V (max), 50 (min)
- one 28 V (max), 300 (min) and one 28 V diode return

#### Sensor Entity Parameters

- $V_{max}$  ( $U_i$ )   30V dc
- $I_{max}$  ( $I_i$ )   100 mA
- $P_i$    750 mW
- $C_i = 0 \mu F$
- $L_i = 0 mH$







### WARNING . . . Explosion Hazard

Do not disconnect  
equipment unless power has been  
switched off or the area is known to be  
non-hazardous.

# VALU-BEAM® SMI912 Series – NAMUR

## Specifications

Supply Voltage and Current	<b>Sensor only:</b> requires 10 to 30V dc, 25 mA maximum <b>Division 1 use (with barriers):</b> requires a minimum system supply voltage of 10 volts (see hookup information and hookup diagrams).
Output Configuration	Current sinking NPN open-collector transistor
Output Rating	Three-wire hookup sinks 15 mA maximum, continuous (10 to 30V dc) Two-wire hookup sinks 10 mA (OFF state) and 20 mA (ON state), 10 to 30V dc. Outputs are short-circuit protected.
Output Response Time	<b>Opposed-mode receivers:</b> 8 milliseconds ON/4 milliseconds OFF; independent of signal strength <b>All other models:</b> 4 milliseconds ON and OFF 100 millisecond delay on power-up (output does not conduct during this time).
Sensing Beam	Infrared (880 nm) or visible red (650 nm), depending on model
Repeatability	<b>Opposed mode:</b> 1.0 millisecond <b>All other modes:</b> 1.3 milliseconds Repeatability is independent of signal strength.
Adjustments	Light/Dark Operate select switch on rear of sensor Sensitivity control on rear of sensor allows precise gain setting (turn clockwise to increase gain)
Indicators	Sensors include Banner's exclusive Alignment Indicating Device (AID™) system, which lights a top-mounted red indicator LED whenever the sensor "sees" its modulated light source, and pulses the LED at a rate proportional to the received light signal strength.
Construction	<b>Housing:</b> reinforced PBT, totally encapsulated <b>Lenses:</b> molded acrylic <b>Hardware:</b> stainless steel
Environmental Ratings	Meets NEMA standards 1, 2, 3, 3S, 4, 4X, 12, and 13, IEC IP66
Connections	Supplied with integral 3-pin Mini-style QD fitting; requires cordset model MBCC (see Accessories), purchased separately.
Operating Conditions	<b>Temperature:</b> -20° to +70° C (-4° to +158° F) <b>Max. Relative Humidity:</b> 90% @ 50° C (non-condensing)
Certifications	   
Application Note	<b>Special Conditions for Safe Use:</b> Parts of the enclosure are non-conducting and may generate an ignition-capable level of ESD. Cleaning of the equipment shall be done only with a damp cloth.

### Approvals

**KEMA:** EN50014, EN50020, EN50284  
 KEMA No. 03ATEX1441X  
 II 2 G EEx ib IIC T5  
 Ta -20 C° .. +70 C°  
  
**CSA:** C22.2 #142-M1987, 157-92, 213-M1987, Exia  
 CL I DIV 1 GP A-D  
 CL I DIV 2 GP A-D  
  
**FM:** 3600, 3610, 3810  
 I.S. CL I, II, III DIV 1 GP A-E, G  
 N.I. CL I, II, III DIV 2 GP A-D, G



# VALU-BEAM® SMI912 Series – NAMUR

## Performance Curves

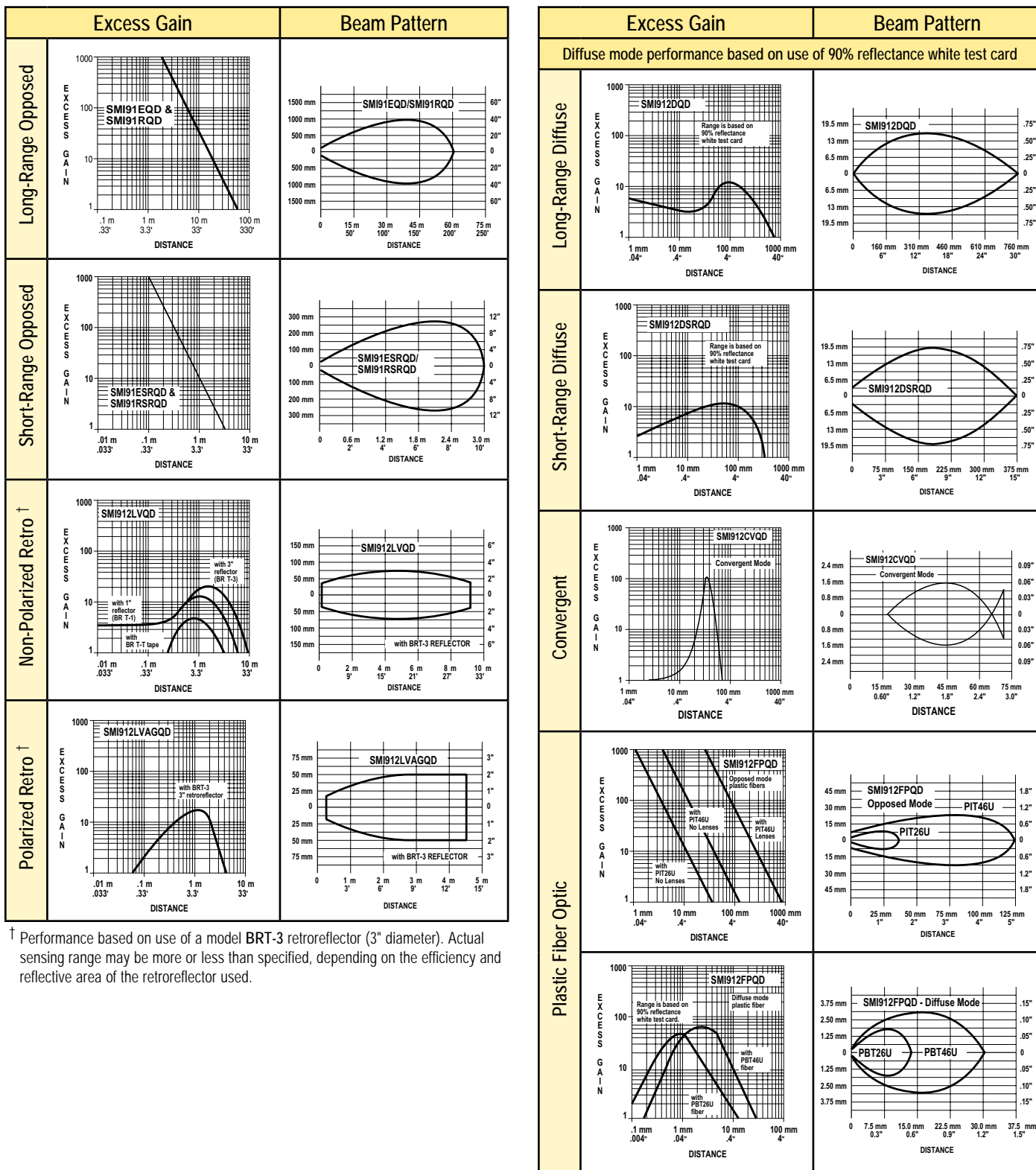

† Performance based on use of a model BRT-3 retroreflector (3" diameter). Actual sensing range may be more or less than specified, depending on the efficiency and reflective area of the retroreflector used.

# VALU-BEAM® SMI912 Series – NAMUR

## Performance Curves

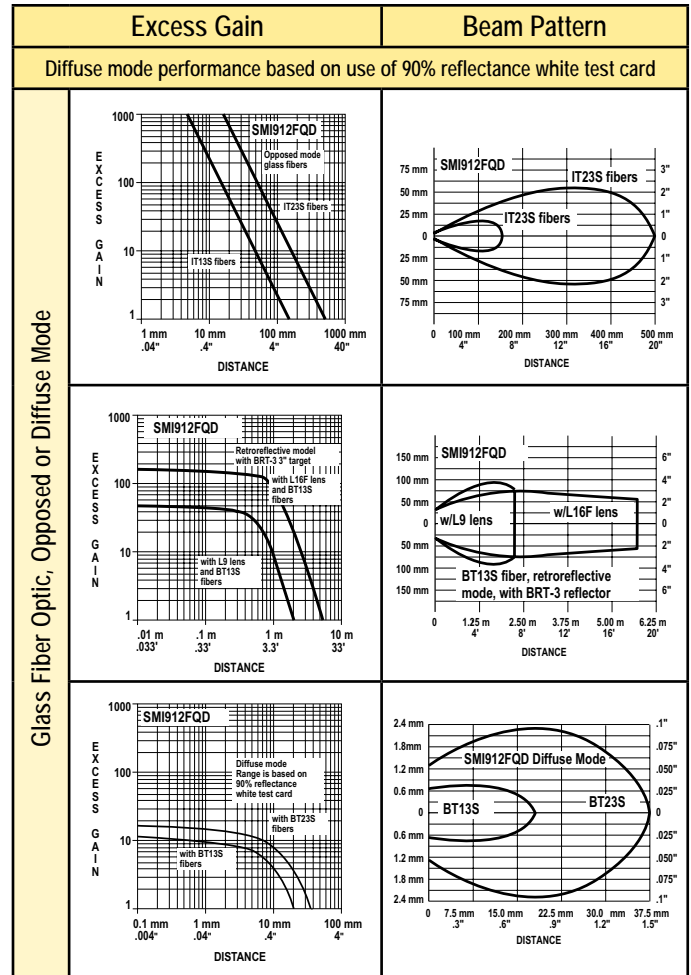
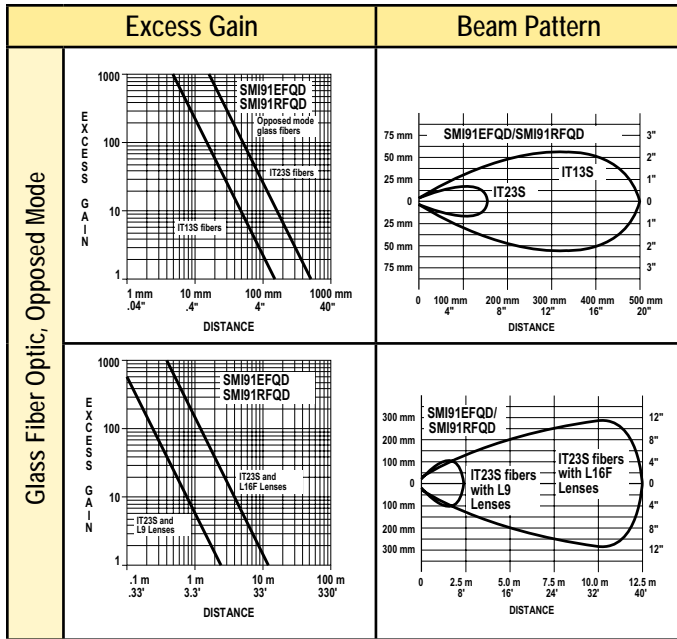

## Dimensions

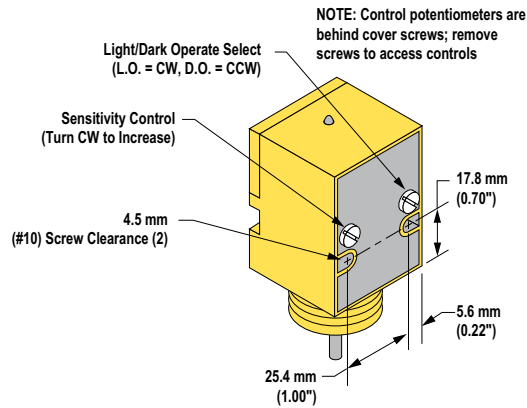
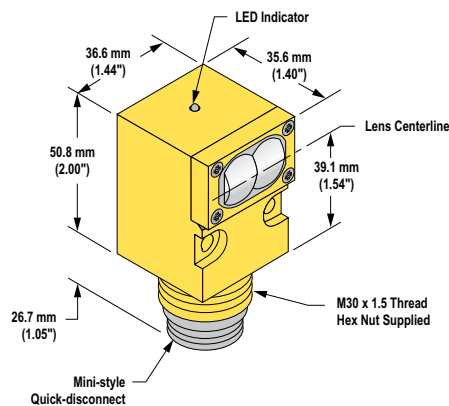

## Hookups

SMI912 Series sensors are certified intrinsically safe ONLY when used with certified energy-limiting intrinsically safe barriers. Banner does not manufacture such barriers; however, our applications engineers can refer you to suppliers of certified barriers that will interface with Banner sensors. SMI912 Series sensors may be wired using Banner Current Amplifier Control Module CI3RC2 (see page 9). Note from the hookup diagrams (page 8) that the installation may be made with either a single barrier (2-wire hookup) or with a double barrier (3-wire hookup). Emitter-only units (SMI91EQD, ESRQD, and EFQD) use the 2-wire hookup; all other models use either 2- or 3-wire hookup.

In the 2-wire configuration, the sensor will act as a current sink, drawing less than 10 mA in the OFF state and more than 20 mA in the ON state. The user must provide a current sensing device ("current sensor" in the diagram) to convert the current to a logic level. In the 3-wire configuration, the output may be used directly to control loads of less than 15 mA.

In selecting the barrier, it is important to consider the barrier's resistance. The sensor must have at least 10 volts across the brown and blue power leads for proper operation, and the barrier will cause a voltage drop due to its resistance. The formula that determines how much resistance is allowed is:

$$R = 40 (\text{supply voltage} - 10 \text{ volts})$$

If the supply voltage is 24V dc, then the maximum resistance is 560 ohms. If the supply voltage is 18V dc, then the maximum resistance is 320 ohms. This includes the resistance of any current sensing device used (in the 2-wire configuration), so the barrier resistance must be further reduced by the current sensor resistance.

Note that, in the 3-wire hookup, the positive load barrier is in series with the load. This will result in an apparent saturation voltage of the output that is higher than the sensor output by the amount of  $I \times R$  (current times resistance) drop through the barrier.

A "positive input" barrier is required for both supply and for load. The sensor's blue (negative supply) lead is normally connected to the ground terminal of the barrier.

The user is responsible for proper installation and maintenance of this equipment, and must conform with the certification requirements relating to barriers and to maximum allowable capacitance and inductance of the field wiring. If in doubt about these requirements, our applications engineers can refer you to the appropriate authority.

# VALU-BEAM® SMI912 Series – NAMUR

## Hookups, continued

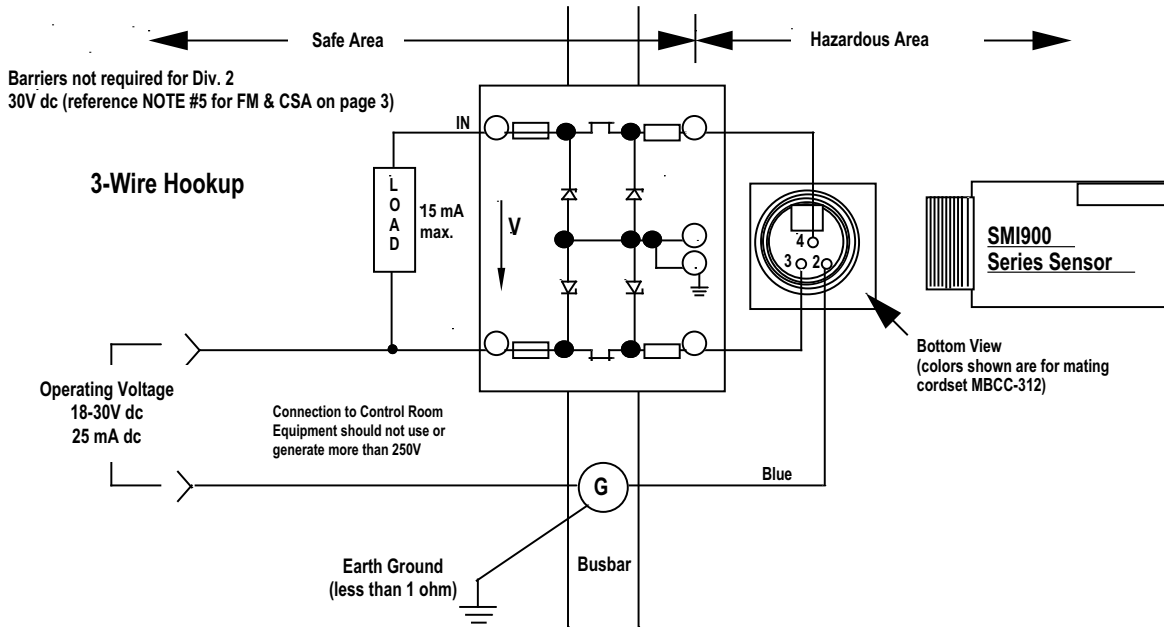

NOTE: Emitters have no output connection (no connection to black wire)

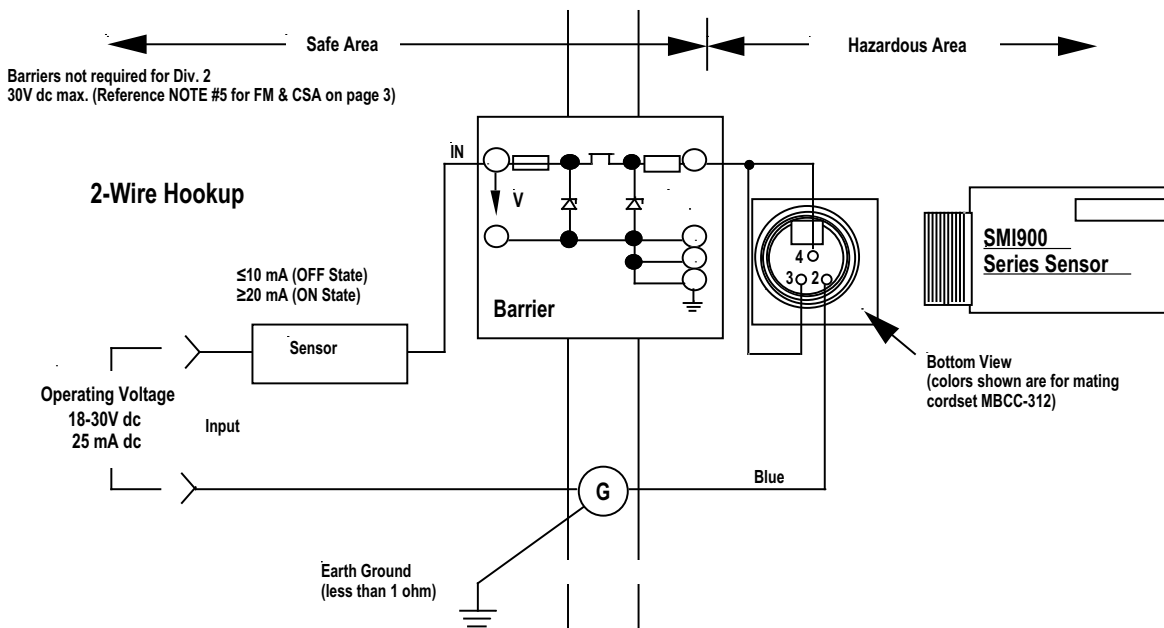

# VALU-BEAM® SMI912 Series – NAMUR

## Accessories

### Quick-Disconnect (QD) Cordsets

All SMI912 Series sensors require a 3-conductor quick-disconnect cordset. Cordset is not included with the sensor and must be ordered separately.

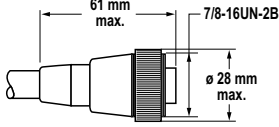
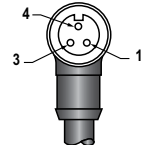
Style	Model	Length	Dimensions	Pinout
3-pin Mini-style Straight	MBCC-306 MBCC-312 MBCC-330	2 m (6.5') 4 m (12') 9 m (30')		 <p>1 = Brown 3 = Blue 4 = Black</p>

### Current Trip-Point Module

Model	Description
	<ul style="list-style-type: none"> <li>Self-contained module converts the SMI912 sensor's current output signal to a trip point switch.</li> <li>SPDT electromechanical relay switches loads that draw up to 5 amps. The SPST solid-state relay can switch a DC load of up to 30V dc, max.; 20 mA max.</li> <li>Powered by either 105-130V ac or 210-250V ac.</li> <li>Supplies dc power to operate a single sensor or both the emitter and receiver of one SMI Series opposed-mode sensor pair. The sensor's input to the CI3RC2 is protected against short circuits. Built-in circuit diagnostics indicate an input overload by flashing an LED status light.</li> <li>Module has two isolated output switches, a 5-amp rated SPDT electromechanical relay and a solid-state transistor switch used for logic-level interfaces.</li> <li>May be ordered either alone or as a part of a kit (see page 10).</li> </ul>

### Current Trip-Point Module Specifications

Supply Voltage	105 to 130V ac or 210 to 250V ac, 50/60 Hz (8 VA)
Output Configuration	<p>SPDT electromechanical relay:</p> <p><b>Contact rating:</b> 250V ac maximum, 24V dc maximum, 5 amps maximum (resistive load), 1/10 HP at 240V ac. Install transient suppressor (MOV) across contacts which switch inductive loads. Min. load: 12V dc, 0.1A.</p> <p><b>Closure time:</b> 10 milliseconds maximum.</p> <p><b>Release time:</b> 10 milliseconds maximum.</p> <p><b>Maximum switching speed:</b> 20 operations/second.</p> <p><b>Mechanical life:</b> 20,000,000 operations</p> <p><b>Solid-state dc relay:</b> SPST optically-coupled transistor; 30V dc maximum, 20 mA maximum.</p>
Emitter Power	+24V dc at 25 mA maximum available at module pin #3
Inputs	<p><b>Trip point for output "OFF":</b> 10 mA</p> <p><b>Trip point for output "ON":</b> 20 mA</p> <p><b>Trip point range for input overload indication:</b> 30 mA   80 mA</p>
Indicators	Status Indicators for OUTPUT "ON" and INPUT overload/short
Construction	<b>Housing:</b> rugged polyphenylene oxide (PPO®) 1.6" x 2.3" x 4" Standard round-pin 11-pole base. Use RS-11 socket or equivalent.
Operating Conditions	<b>Temperature:</b> 0° to +50° C (+32° to +122° F)

# VALU-BEAM® SMI912 Series – NAMUR

## Accessories, continued

### Intrinsic Safety Barriers

Model (Barrier Only)	Barrier Description	Kit Model	Kit Description
CIB-1	Single-channel intrinsically safe barrier	C12BK-1	Includes CI3RC2 current amplifier, one RS-11 socket, one DIN-rail mount, one single-channel intrinsically safe barrier
C12B-1	Dual-channel intrinsically safe barrier (typically used in opposed-mode applications)	C12BK-2	Includes CI3RC2 current amplifier, one RS-11 socket, one DIN-rail mount, one dual-channel intrinsically safe barrier

### Current Trip-Point Module Hookups

#### Hookup for Opposed-Mode Emitters and Receivers

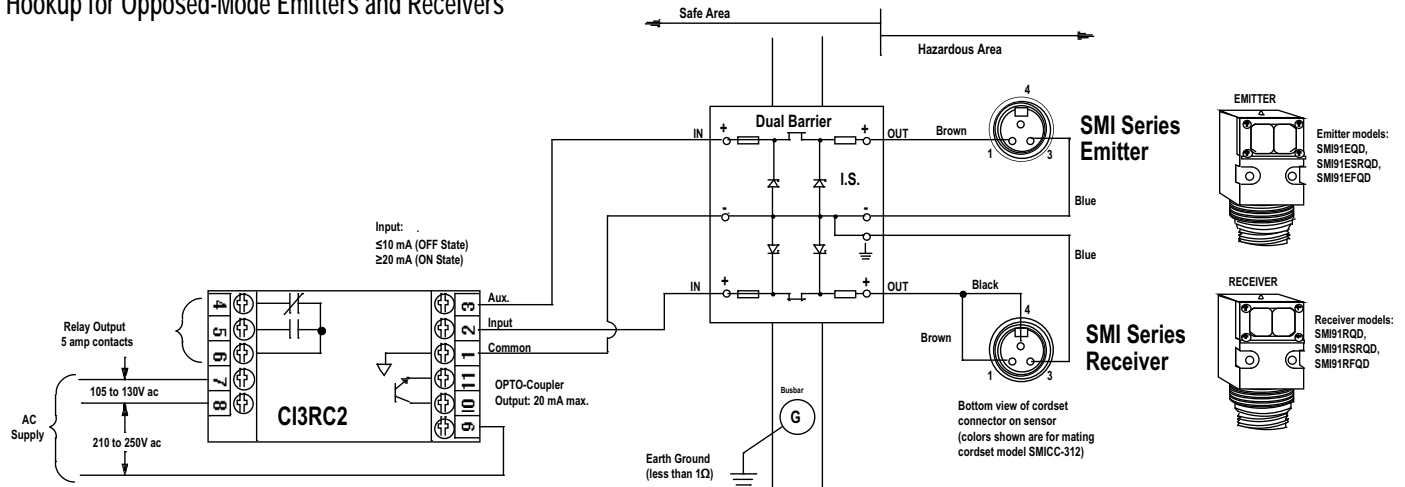

#### Hookup for Other SMI912 Series Sensors

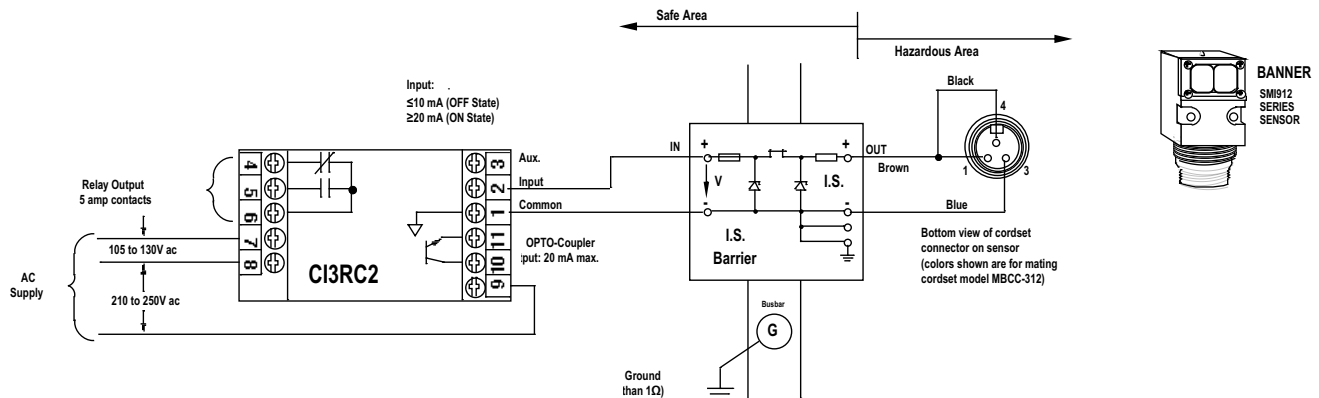



# VALU-BEAM® SMI912 Series — NAMUR

## Accessories, continued

### Mounting Brackets

Bracket dimensions are available online

<b>SMB30MM</b>	<ul style="list-style-type: none"><li>• 30 mm 12-gauge, 304 stainless steel, right-angle mounting bracket with a curved mounting slot for versatile orientation</li><li>• Clearance for M6 (1/4") hardware</li></ul>		<b>SMB30A</b>	<ul style="list-style-type: none"><li>• 30 mm right-angle mounting bracket with a curved mounting slot for versatile orientation</li><li>• 12-gauge stainless steel</li><li>• Clearance for M6 (1/4") hardware</li></ul>	
<b>SMB30SC</b>	<ul style="list-style-type: none"><li>• 30 mm swivel bracket</li><li>• Black reinforced thermoplastic polyester</li><li>• Includes stainless steel mounting and swivel locking hardware</li></ul>	