



WORLD-BEAM® QS18EFP

Expert™ Plastic Fiber Optic Sensor with a Visible Red Beam



Contact Factory for more information.

Features

- Easy-to-set automatic Expert-style Static and Dynamic TEACH options, plus Window, Light, and Dark SET, via push button or remote input
- Smart power-control algorithm to maximize performance in low-contrast applications
- Easy push-button or remote Dark-Operate/Light-Operate select and selectable 30 ms output OFF-delay
- Less than 1 millisecond output response for excellent sensing repeatability
- Tough ABS housing is rated IEC IP67; NEMA 6
- Bright LED operating status indicators are visible from 360°
- Discrete PNP or NPN output, depending on model
- Multiple connection options available (see Models)
- Compact housing, easy side-mount installation

Models

	Model	Range	Cable*	Supply Voltage	Output Type
660 nm Visible Red PLASTIC FIBER	QS18EN6FP	Range varies by sensing mode and fiber optics used	2 m (6.5') 5-wire cable	10 to 30V dc	NPN
	QS18EP6FP				PNP

* Only standard 2 m (6.5') cable models are listed. For 9 m (30') cable, add suffix "W30" to the model number (e.g., QS18EN6FP W30). A model with a QD connector requires a mating cable; see page 11.

QD models:

- For 4-pin 150 mm (6") Euro-style pigtail, add suffix "Q5" (e.g., QS18EN6FPQ5).
- For 4-pin Integral Euro-style QD, add suffix "Q8" (e.g., QS18EN6FPQ8).

- For 4-pin 150 mm (6") Pico-style pigtail, add suffix "Q" (e.g., QS18EN6FPQ).
- For 4-pin Integral Pico-style QD, add suffix "Q7" (e.g., QS18EN6FPQ7).



WARNING . . . Not To Be Used for Personnel Protection

Never use these products as sensing devices for personnel protection. Doing so could lead to serious injury or death.

These sensors do NOT include the self-checking redundant circuitry necessary to allow their use in personnel safety applications. A sensor failure or malfunction can cause either an energized or de-energized sensor output condition. Consult your current Banner Safety Products catalog for safety products which meet OSHA, ANSI and IEC standards for personnel protection.

WORLD-BEAM® QS18EFP

Overview

The QS18EFP is an easy-to-use plastic fiber optic sensor that provides high-performance sensing in low-contrast applications. Its visible red beam provides easy fiber optic alignment. The sensor offers multiple configuration options, in addition to remote programming and security lockout options.

The sensor features a discrete output, NPN or PNP, depending on model.

The sensor's compact housing has two bright LEDs for easy configuration and status monitoring during operation. The sensor can be side-mounted, using its integral mounting holes, directly to a mounting surface or using an accessory bracket (see page 11).

Sensor Configuration

Sensor configuration is accomplished via any of five TEACH or SET options, plus two SETUP options. After TEACH or SET have been used to define the sensing limits, a SETUP procedure may be used to enable a 30 ms OFF-delay or to change the Light-/Dark-Operate setting (see page 8). The push button or the remote wire may be used to access and set the parameters.

Sensing limit configuration options include:

- Dynamic (on-the-fly) TEACH: a single switching threshold, determined by multiple sampled conditions
- Static TEACH: a single switching threshold, determined by two taught conditions
- Window SET: a sensing window, centered on a single sensing condition
- Light SET and Dark SET: a single switching threshold, offset from a single sensing condition

Remote Configuration

The remote function may be used to configure the sensor remotely or to disable the push button for security. Connect the white wire of the sensor to ground (0V dc), through a remote programming switch. Pulse the remote line according to the diagrams in the configuration procedures. The length of the individual programming pulses is equal to the value T:

0.04 seconds T 0.8 seconds

Returning to RUN Mode without Saving Settings

Static TEACH and SET modes may be exited either after the automatic 60-second time-out, or by manually exiting the process: press and hold the push button (or hold the remote line low) for 2 seconds. The sensor returns to RUN mode without saving any new settings.

Output Status and Configuration

The sensor's output is disabled during all TEACH and SET procedures, and is enabled upon return to RUN mode.

Following any TEACH or SET procedure other than Static TEACH, the Output ON condition (Light- or Dark-Operate setting) will remain as it was last configured. To change the Light-/Dark-Operate setting or to change the OFF-delay setting, see page 8.

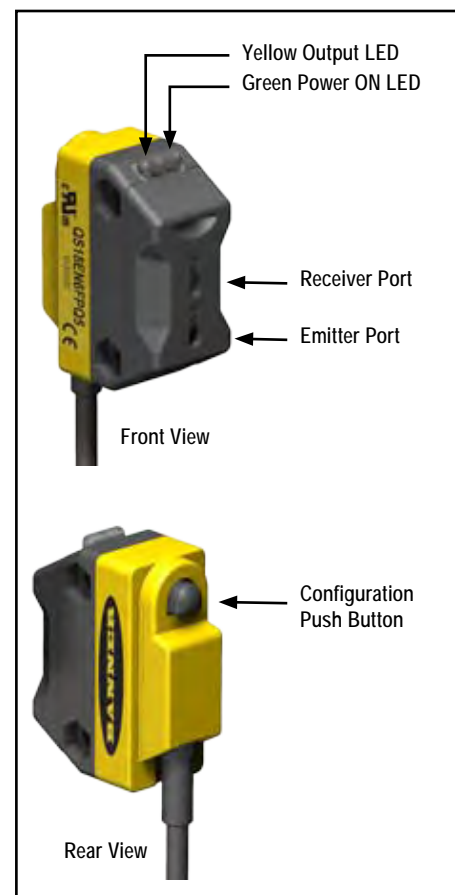

Figure 1. Features

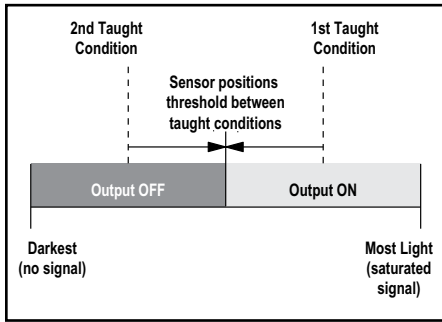







Figure 2. Static TEACH (Light Operate shown)

Static TEACH

- Sets a single switching threshold (switchpoint)
- Recommended for applications where two conditions can be presented by the user

Static TEACH is the traditional configuration method. The sensor locates a single switchpoint at the optimal location between the two taught conditions, with the Output ON condition on one side, and the Output OFF condition on the other (see Figure 2).

The first condition taught is the ON condition. The Output ON and OFF conditions can be reversed by reversing the teach order or by changing the Light-/Dark-Operate setting (see page 8).

	Push Button 0.04 seconds "Click" 0.8 seconds	Remote Line 0.04 seconds T 0.8 seconds	Result
Access Static TEACH Mode	<ul style="list-style-type: none"> • Press and hold push button 2–4 seconds. 	No action required; sensor is ready for 1st sensing condition.	Sensor waits for 1st sensing condition. Power LED: OFF Output LED: Slow flash (1 Hz)
Teach 1st Sensing Condition	<ul style="list-style-type: none"> • Present 1st sensing condition. • Click push button. 	<ul style="list-style-type: none"> • Present 1st sensing condition. • Single-pulse remote line. 	Power LED: OFF Output LED: Double-flash
Teach 2nd Sensing Condition and Return to RUN Mode	<ul style="list-style-type: none"> • Present 2nd sensing condition. • Click push button. 	<ul style="list-style-type: none"> • Present 2nd sensing condition. • Single-pulse remote line. 	<p style="text-align: center;">Teach Accepted</p> Power LED: Flashes 3x, then ON Green Output LED: OFF Sensor returns to RUN mode with new settings.
			<p style="text-align: center;">Teach Unacceptable</p> Power LED: OFF Output LED: Slow flash (1 Hz) Sensor returns to wait state, ready for 1st sensing condition.

WORLD-BEAM® QS18EFP

Dynamic TEACH

- Teach on-the-fly
- Sets a single switching threshold (switchpoint)
- Recommended for applications where a machine or process may not be stopped for teaching

Dynamic TEACH configures the sensor during actual sensing conditions, taking multiple samples of the light and dark conditions and automatically setting the threshold at the optimum level (see Figure 3).

When Dynamic TEACH is used, the Output ON state (Light- or Dark-Operate setting) will remain as it was last configured. To change the Light-/Dark-Operate setting, see page 8.

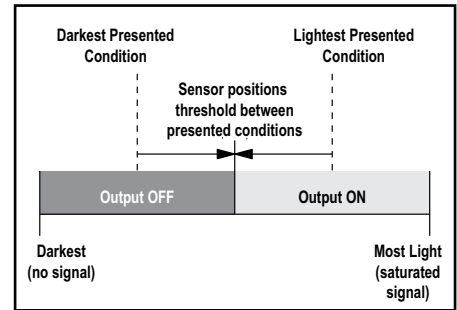

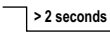





Figure 3. Dynamic TEACH (Light Operate shown)

	Push Button	Remote Line	Result
Access Dynamic TEACH Mode	<ul style="list-style-type: none"> • Press and hold push button > 4 seconds. 	<ul style="list-style-type: none"> • Hold remote line low (to ground) > 2 seconds. 	Power LED: OFF Output LED: Quick flash (2 Hz)
TEACH Sensing Conditions	<ul style="list-style-type: none"> • Continue to hold push button. • Present Output ON and OFF conditions. 	<ul style="list-style-type: none"> • Continue to hold remote line low (to ground). • Present Output ON and OFF conditions. 	Power LED: OFF Output LED: Quick flash (2 Hz)
Return to RUN Mode	<ul style="list-style-type: none"> • Release push button. 	<ul style="list-style-type: none"> • Release remote line/switch. 	Teach Accepted Power LED: Flashes 3x, then ON Green Output LED: OFF,* then ON or OFF, depending on output state Sensor returns to RUN mode with new settings.
			Teach Unacceptable Power LED: Flashes 3x, then ON Green Output LED: ON,* then ON or OFF, depending on output state Sensor returns to RUN mode without changing settings.

* Initial Output LED condition is simultaneous with Power LED 3-flash.

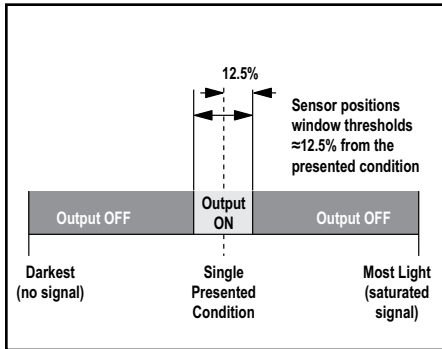



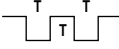

Figure 4. Window SET (Light Operate shown)

Window SET

- Sets a single sensing window that extends approximately 12.5% above and below the presented condition.
- All other conditions (lighter or darker) cause the output to change state.
- In Light-Operate mode, the presented condition is the Output ON condition. In Dark-Operate mode, the presented condition is the Output OFF condition.
- Recommended for applications where the target to be sensed may not always appear in the same place.

Window SET designates a sensing window, by setting two switching thresholds at approximately 12.5% above and below the presented sensing condition (see Figure 4). Output ON and OFF conditions can be reversed by changing the Light-/Dark-Operate setting (see page 8).

	Push Button 0.04 seconds "Click" 0.8 seconds	Remote Line 0.04 seconds T 0.8 seconds	Result
Access Window SET Mode	<ul style="list-style-type: none"> • Press and hold push button 2–4 seconds. 	<ul style="list-style-type: none"> • Single-pulse remote line. 	Sensor waits for sensing condition.
			<p style="text-align: center;">Push Button</p> Power LED: OFF Output LED: Slow flash (1 Hz)
Set Sensing Condition and Return to RUN Mode	<ul style="list-style-type: none"> • Present sensing condition. • Double-click push button. 	<ul style="list-style-type: none"> • Present sensing condition. • Double-pulse remote line. 	<p style="text-align: center;">Threshold Condition Accepted</p> Power LED: Flashes 3x, then ON Green Output LED: OFF,* then ON or OFF, depending on output state Sensor returns to RUN mode with new settings.
			<p style="text-align: center;">Threshold Condition Unacceptable</p> Power LED: OFF Output LED: Slow flash (1 Hz) Sensor returns to wait state, ready for sensing condition.

* Initial Output LED condition is simultaneous with Power LED 3-flash.

WORLD-BEAM® QS18EFP

Light SET

- Sets a threshold approximately 12.5% below the presented sensing condition.
- Any condition darker than the threshold causes the output to change state.
- In Light-Operate mode, the presented condition is the Output ON condition. In Dark-Operate mode, the presented condition is the Output OFF condition.
- Recommended for applications where only one condition is known, for example a stable light background with varying darker targets.

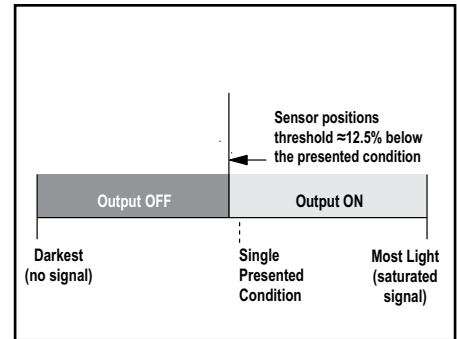



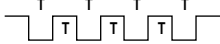

Figure 5. Light SET (Light Operate shown)

A single sensing condition is presented, and the sensor positions a threshold approximately 12.5% below the presented condition (see Figure 5). When a condition darker than the threshold is sensed, the output changes state. To change the Light-/Dark-Operate setting, see page 8.

	Push Button 0.04 seconds "Click" 0.8 seconds	Remote Line 0.04 seconds T 0.8 seconds	Result
Access Light SET Mode	<ul style="list-style-type: none"> • Press and hold push button 2–4 seconds. 	<ul style="list-style-type: none"> • Single-pulse remote line. 	Sensor waits for sensing condition. Push Button Power LED: OFF Output LED: Slow flash (1 Hz)
			Remote Line Power LED: OFF Output LED: Double-flash
Set Sensing Condition and Return to RUN Mode	<ul style="list-style-type: none"> • Present sensing condition. • Four-click push button. 	<ul style="list-style-type: none"> • Present sensing condition. • Four-pulse remote line. 	Threshold Condition Accepted Power LED: Flashes 3x, then ON Green Output LED: OFF,* then ON or OFF, depending on output state Sensor returns to RUN mode with new settings.
			Threshold Condition Unacceptable Power LED: OFF Output LED: Slow flash (1 Hz) Sensor returns to wait state, ready for sensing condition.

* Initial Output LED condition is simultaneous with Power LED 3-flash.

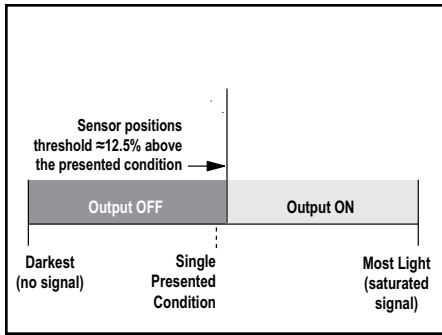



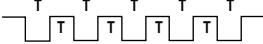

Figure 6. Dark SET (Light Operate shown)

Dark SET

- Sets a threshold approximately 12.5% above the presented sensing condition.
- Any condition lighter than the threshold causes the output to change state.
- In Light-Operate mode, the presented condition is the Output OFF condition. In Dark-Operate mode, the presented condition is the Output ON condition.
- Recommended for applications where only one condition is known, for example a stable dark background with varying lighter targets.

A single sensing condition is presented, and the sensor positions a threshold approximately 12.5% above the presented condition (see Figure 6). When a condition lighter than the threshold is sensed, the output changes state. To change the Light-/Dark-Operate setting, see page 8.

	Push Button 0.04 seconds "Click" 0.8 seconds	Remote Line 0.04 seconds T 0.8 seconds	Result
Access Dark SET Mode	<ul style="list-style-type: none"> • Press and hold push button 2–4 seconds. 	<ul style="list-style-type: none"> • Single-pulse remote line. 	Sensor waits for sensing condition. <div style="text-align: center;">Push Button</div> Power LED: OFF Output LED: Slow flash (1 Hz)
			<div style="text-align: center;">Remote Line</div> Power LED: OFF Output LED: Double-flash
Set Sensing Condition and Return to RUN Mode	<ul style="list-style-type: none"> • Present sensing condition. • Five-click push button. 	<ul style="list-style-type: none"> • Present sensing condition. • Five-pulse remote line. 	<div style="text-align: center;">Threshold Condition Accepted</div> Power LED: Flashes 3x, then ON Green Output LED: OFF,* then ON or OFF, depending on output state Sensor returns to RUN mode with new settings.
			<div style="text-align: center;">Threshold Condition Unacceptable</div> Power LED: OFF Output LED: Slow flash (1 Hz) Sensor returns to wait state, ready for sensing condition.

* Initial Output LED condition is simultaneous with Power LED 3-flash.

WORLD-BEAM® QS18EFP

Sensor SETUP



Sensor SETUP is used to change sensor output response for the following options:

- 30-millisecond pulse stretcher (OFF-delay), if required
- Light- or Dark-Operate setting

SETUP functions are accessed directly from RUN mode, using the procedures detailed below.

OFF-Delay (Pulse Stretcher) Enable/Disable

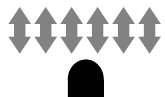

The QS18EFP features a 30-millisecond OFF-delay option. Perform the procedure below to either enable or disable the feature, using either the push button or the remote line.

	Push Button 0.04 seconds "Click" 0.8 seconds	Remote Line 0.04 seconds T 0.8 seconds	Result
OFF-Delay Enable/Disable	<ul style="list-style-type: none"> • From RUN mode, six-click the push button. 	<ul style="list-style-type: none"> • From RUN mode, six-pulse remote line. 	Sensor toggles between enable/disable settings and returns to RUN mode. Power LED: Flashes 3x, then ON Green Output LED: Enabled – ON,* Disabled – OFF,* Then ON or OFF, depending on output state

* Initial Output LED condition is simultaneous with Power LED 3-flash.

Light-Operate/Dark-Operate Select

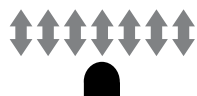
Light-Operate or Dark-Operate may be selected, using either the push button or the remote line.

	Push Button 0.04 seconds "Click" 0.8 seconds	Remote Line 0.04 seconds T 0.8 seconds	Result
Light-/Dark-Operate Select	<ul style="list-style-type: none"> • From RUN mode, seven-click the push button. 	<ul style="list-style-type: none"> • From RUN mode, seven-pulse remote line. 	Sensor toggles between Light-/Dark-Operate settings and returns to RUN mode. Power LED: Flashes 3x, then ON Green Output LED: Light Operate – ON,* Dark Operate – OFF,* Then ON or OFF, depending on output state

* Initial Output LED condition is simultaneous with Power LED 3-flash.

Push Button Enable/Disable

In addition to its configuration functions, the remote input may be used to disable the sensor push button for security, to prevent unauthorized adjustment. Perform the procedure below to either enable or disable the feature, via the remote line only. Connect the white wire of the sensor as described on page 2.

	Push Button 0.04 seconds "Click" 0.8 seconds	Remote Line 0.04 seconds T 0.8 seconds	Result
Push Button Enable/Disable	<ul style="list-style-type: none"> • Not available 	<ul style="list-style-type: none"> • From RUN mode, four-pulse the remote line. 	Sensor toggles between enable/disable settings and returns to RUN mode. Power LED: Flashes 3x, then ON Green Output LED: OFF, * then ON or OFF, depending on output state

* Initial Output LED condition is simultaneous with Power LED 3-flash.

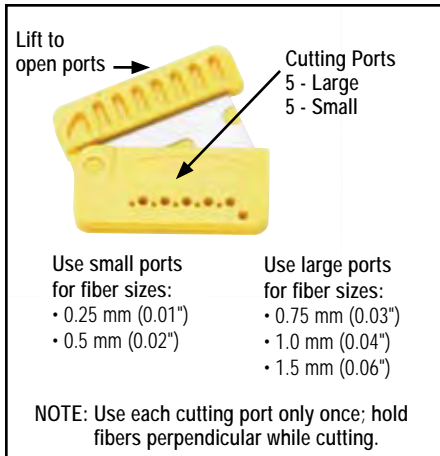

Figure 7. PFC-2 plastic fiber cutter (supplied with fiber)

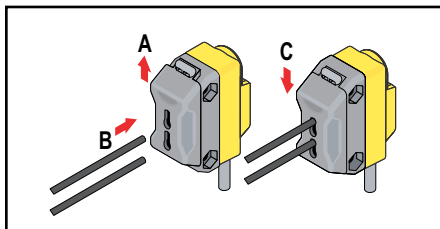

Figure 8. Installing plastic fibers

Installation Notes

Cutting Underminated Plastic Fibers. Fibers are designed to be field-cut to the required length. A cutting device is supplied with the fiber (see Figure 7).

1. Locate the unfinished end of the fiber. Determine the length of fiber required for the application. If using a bifurcated fiber, separate the two halves of the fiber at least 2" beyond the fiber cutting location. Open the cutter blade to open the cutting ports. Insert one of the unfinished ends through one of the cutting ports on the cutter so that the excess fiber protrudes from the back of the cutter.
2. Double-check the fiber length, and close the cutter to cut the fiber. Using a different port, cut the second fiber to the required length. **To ensure a clean cut each time, do not use a cutting port more than once.**
3. Wipe the cut ends of the fiber with a clean, dry cloth to remove any contamination. **Do not use solvents or abrasives on any exposed optical fiber.**

Plastic Fiber Installation. Refer to Figure 8.

- A. Unlock the fiber gripper as shown. If 0.25 mm or 0.5 mm core fibers are being used, slide the small fiber adapters onto the fibers, flush with the fiber ends.
- B. Gently insert the prepared plastic fiber ends into the ports, as far as they will go.
- C. Slide the fiber gripper back to lock.

Specifications

Supply Voltage	10 to 30V dc (10% maximum ripple) at less than 35 mA, exclusive of load; 10 to 24V dc @ >55°C Protected against reverse polarity and transient voltages
Output Configuration	NPN or PNP (current sinking or sourcing), depending on model Rating: 100 mA maximum Off-state leakage current: less than 50 µA @ 30V dc ON-state saturation voltage: less than 1.5V (2 m cable); 1.7V (9 m cable) Protected against false pulse on power-up and continuous overload or short circuit of output
Output Response Time	600 microseconds ON/OFF NOTE: Momentary delay on power-up; outputs do not conduct during this time
Repeatability	75 microseconds
Adjustments	<ul style="list-style-type: none"> • Thresholds: Push-button or remote-wire configurable • Light/Dark Operate: Selectable indirectly via configuration order in Static TEACH mode (Output ON follows the first target condition), or directly via push button or remote line; see page 8 • Push Button enable/disable (remote wire only) • OFF-Delay enable/disable (see page 8)
Indicators	2 LED indicators: Green: RUN mode, output short-circuit Yellow: Output ON/marginal, TEACH mode
Construction	ABS housing, rated IEC IP67; NEMA 6
Connections	2 m (6.5') 4-wire PVC cable, 9 m (30') PVC cable, integral Pico-style or Euro-style QD connector, 150 mm (6") Pico-style pigtail QD, or 150 mm (6") Euro-style pigtail QD, depending on model
Operating Conditions	Temperature: -20° to +70° C (-4° to + 158° F) Relative Humidity: 90% @ 50° C (non-condensing)
Application Notes	<ul style="list-style-type: none"> • If the push button does not appear to be responsive, perform the push button enable procedure (page 8). • To maintain backwards compatibility with earlier models, 3 remote line pulses or a push button hold followed by 3 push button clicks will perform a Dark SET.

WORLD-BEAM® QS18EFP

Performance Curves

(Performance using Dark SET, performed in no-light condition)

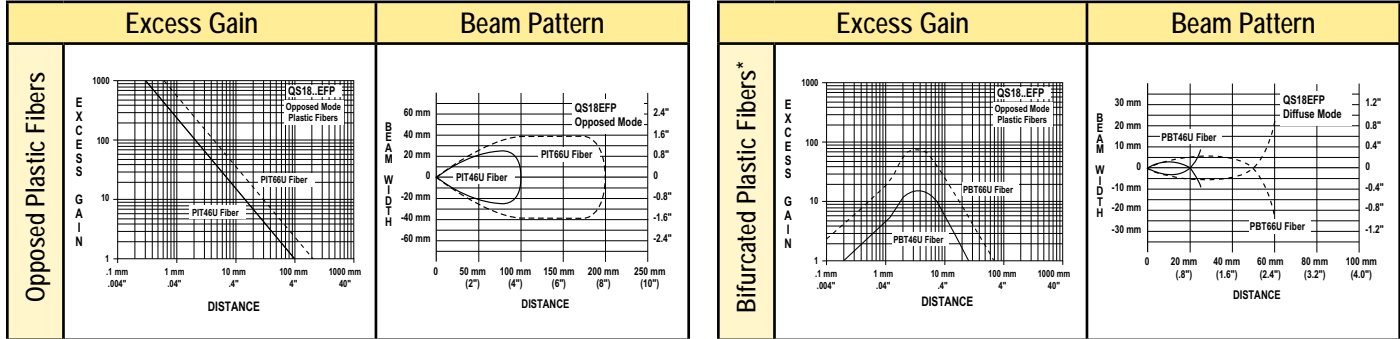

* Diffuse-mode performance based on use of 90% reflectance white test card

Dimensions

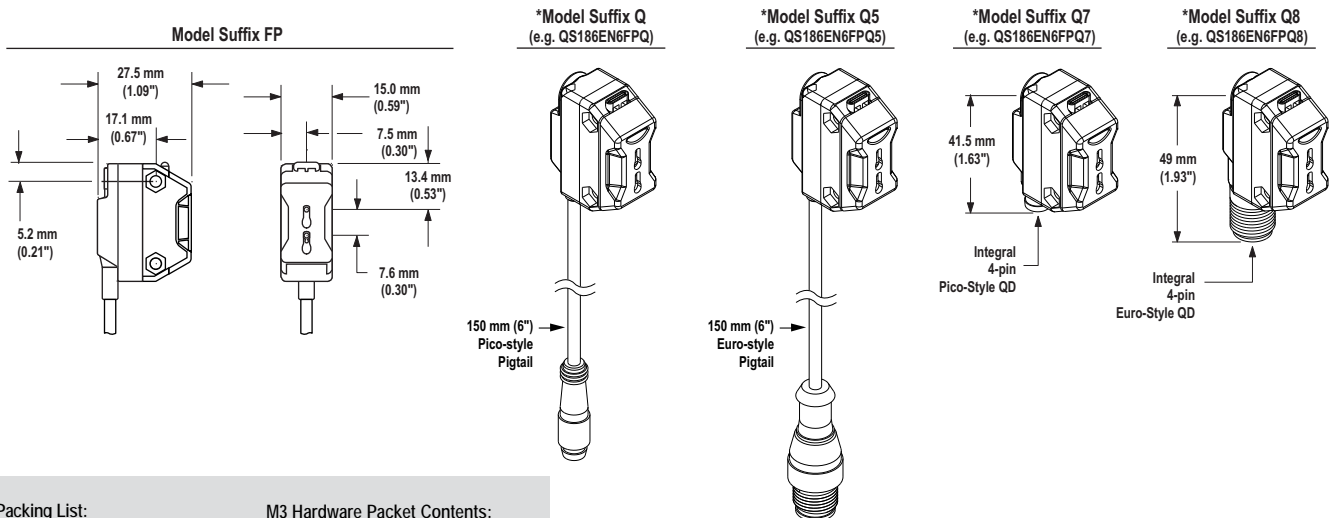

Packing List:

Sensor
 M3 hardware packet
 Data sheet, P/N 130562

M3 Hardware Packet Contents:

2 - M3 x 0.5 x 20 mm SS Screw
 2 - M3 x 0.5 SS-Hex Nut
 2 - M3 SS Washer

Hookups

NPN Models

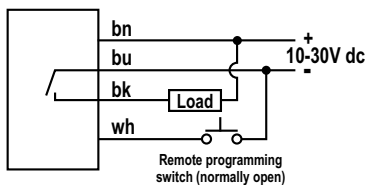

PNP Models

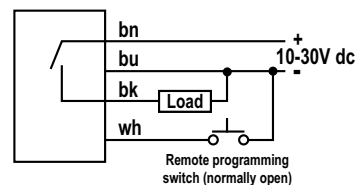

Cabled hookups only are shown. QD hookups are functionally identical.

Accessories

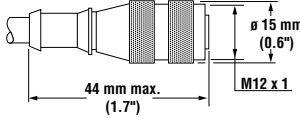
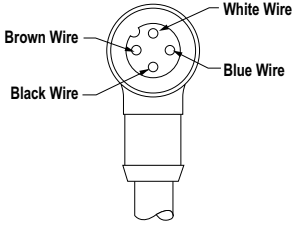
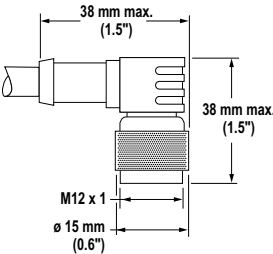
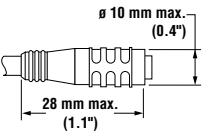
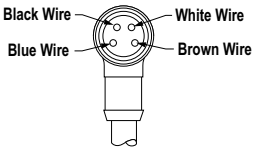
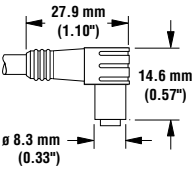

Quick-Disconnect Cables

Style	Model	Length	Dimensions	Pinout
4-pin Euro-style straight	MQDC-406 MQDC-415 MQDC-430	2 m (6.5') 5 m (15') 9 m (30')		
4-pin Euro-style right-angle	MQDC-406RA MQDC-415RA MQDC-430RA	2 m (6.5') 5 m (15') 9 m (30')		
4-pin Pico-style straight	PKG4-2	2 m (6.5')		
4-pin Pico-style right-angle	PKW4-2	2 m (6.5')		

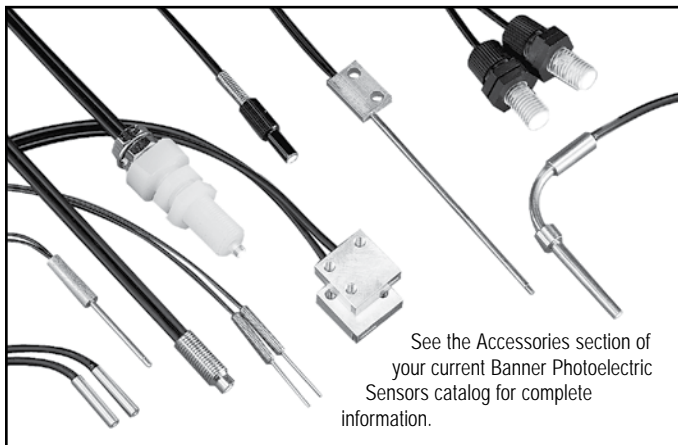
Plastic Fiber Optics

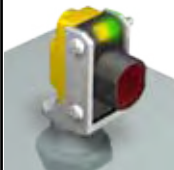

Accessory Mounting Brackets

SMB312S	<ul style="list-style-type: none"> • 2-axis, side-mounting bracket • Stainless steel 	
SMBQS18Y	<ul style="list-style-type: none"> • Die-cast bracket for mounting into 18 mm holes • Accommodates Euro-style QD connectors and cables 	
SMBQS18DIN	<ul style="list-style-type: none"> • 2-piece bracket for mounting to 35 mm DIN rail • 300 series stainless steel and glass-filled nylon; zinc-plated steel screw 	

Other sensor models shown