

**MULTI-FUNCTIONAL
SAFETY RELAY
YRB-0330-242**



MAIN FEATURES

- Safety Integrity Level (SIL) 3 according to IEC/EN 61508
- Claimed Level (SIL CL) 3 according to IEC/EN 62061
- Performance Level (PL) e and category 4 according to EN/ISO 13849-1
- Safety category 4 according to EN 954-1
- Certified TÜV, CE and UL
- Outputs:
 - 3 x N.O. safety contacts
 - 2 semiconductor outputs, short-circuit and overload protected
- Wire-break detection on AOPD input
- With under- and overvoltage detection and indication
- Reaction time: max. 30 ms
- LED indicators for RUN operation, channel 1/2
- 45 mm wide, DIN-rail-mountable housing

APPLICATION AREA

- The following operation types can be selected by means of a rotary switch:
 - **Protective operation**, e.g. light curtains
 - **Protective operation with muting**, e.g. conveyor belts
 - Setting of various signal cycles of muting sensors
 - Setting of max. permissible muting time
 - Override function by means of start button
 - **Stepping operation**, e.g. presses
 - 1, 2 or 3 cycles
 - Number of cycles can be set by means of key switch
- Suitable for connection of type 4 AOPDs or type 2 AOPDs according to IEC/EN 61496-1, cross-circuit monitoring in AOPDs
- Connection of max.
 - 3 2-channel AOPDs, or
 - 2 2-channel AOPDs and 2 1-channel muting sensors, or
 - 1 2-channel AOPD and 4 1-channel muting sensors, or
 - 2 2-channel AOPDs and key switch for cycle switching
 - additionally: start button and machine contact with line-fault detection

TECHNICAL DATA

INPUT

Nominal voltage U_N	24 VDC
Voltage range at max. 5% ripple content	0.85 ... 1.15 U_N
Nominal consumption	max. 170 mA (no load on semiconductor outputs)
Control voltage on	
S21, S23, S31, S33, S41, S43, 48, 58	23 VDC at U_N
Control current on	
S12, S14, S22, S24, S32, S34, S42, S44	4.5 mA each at U_N
Min. voltage on	
S12, S14, S22, S24, S32, S34, S42, S44	16 VDC
Device protection	Internal by means of PTC
Min. current on M1, M2	25 mA (lamp active)

OUTPUT

Contacts	3 x N.O.
Contact type	Relay, positively driven
Operating delay (typ. at U_N):	
Manual start	max. 50 ms
Automatic start	max. 1.5 s
Automatic restart	max. 55 ms
Release delay (reaction time)	max. 30 ms
	(max. 50 ms when error on AOPD and only 1 input channel of AOPD off)
Nominal output voltage	250 VAC
Switching of low loads	DC: see limit curve for arc-free operation
Thermal current I_{th}	5 A
Switching capacity	
to AC 15	3 A / 230 VAC IEC/EN 60947-5-1
to DC 13 at 0.1 Hz	8 A / 24 VDC IEC/EN 60947-5-1

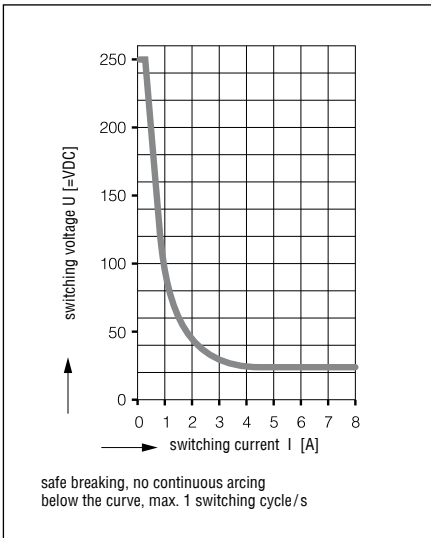

Limit curve for arc-free operation

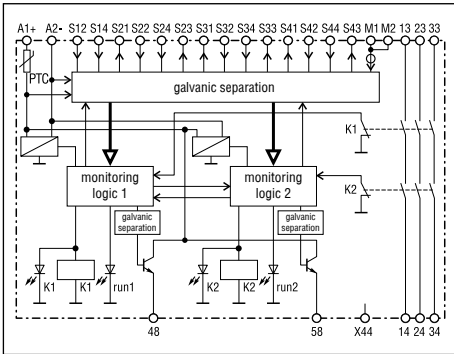

Block diagram

SEMICONDUCTOR OUTPUTS

Output (terminals 48 and 58)	Transistor outputs, plus switching
Nominal output voltage	24 VDC, max. 100 mA continuous current, max. 400 mA for 0.5s internal short-circuit, over-temperature and overload protection

GENERAL DATA

Electrical life	10 ⁵ switching cycles	IEC/EN 60947-5-1
to AC 15 at 2 A, AC 230 V		
Permissible operating frequency	max. 1200 switching cycles/h	
Short-circuit strength:		
max. fuse rating	6 A gL	IEC/EN 60947-5-1
line circuit breaker	C 8 A	
Mechanical life	10 x 10 ⁶ switching cycles	
Temperature range	0 ... +50 °C (+32 ... +122 °F)	
Clearance and creepage distance:		
Nominal impulse voltage / Pollution degree	4 kV / 2	IEC/EN 60664-1
EMC:		
Electrostatic discharge (ESD)	8 kV (contact discharge) IEC/EN 61000-4-2 (according to test degree 3)	
HF irradiation	10 V / m IEC/EN 61000-4-3	
Fast transients:		
- on power supply wires A1 - A2	2 kV	IEC/EN 61000-4-4
- on signal and control wires	2 kV	IEC/EN 61000-4-4
Surge voltage:		
- between power supply wires	1 kV	IEC/EN 61000-4-5
- between wire and ground	2 kV	IEC/EN 61000-4-5
- HF-wire guided	10 V	IEC/EN 61000-4-6
Interference suppression	Limit value class B EN 55011	
Degree of protection:	according to IEC/EN 61496-1 (1997), the device must be installed in a control housing with degree of protection 54.	
Housing	IP 40	IEC/EN 60529
Terminals	IP 20 IEC/EN 60529	
Housing	Thermoplastic polymer with V0 behavior acc. to UL Subject 94	
Vibration resistance according to IEC/EN 61496-1	Amplitude 0.35 mm Frequency 10 ... 55 Hz IEC/EN 60068-2-6	
Shock resistance:		
Acceleration	10 g	
Impulse length	16 ms	
Number of shocks	1000 per axis on three axes	
Climatic resistance	0 / 050 / 04	IEC/EN 60068-1
Terminals	EN 50005	
Wire connection	according to DIN 46228-1/-2/-3/-4	
Wire fixing	M3.5 captive plus-minus terminal screws	
	Box terminal with wire protection	
Mounting	DIN rail	IEC/EN 60715
Weight	320 g	
Dimensions (W x H x D)	45 x 84 x 118 mm	

PART REFERENCE

Multi-functional safety relay	YRB-0330-242
-------------------------------	--------------

APPLICATION EXAMPLES

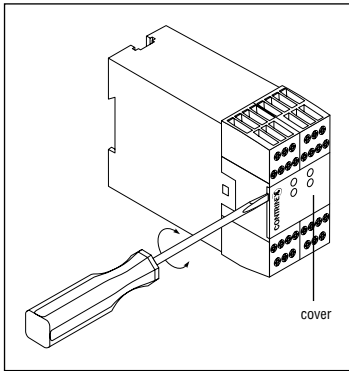

Device setting

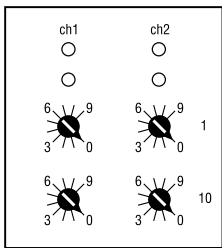

Inside view

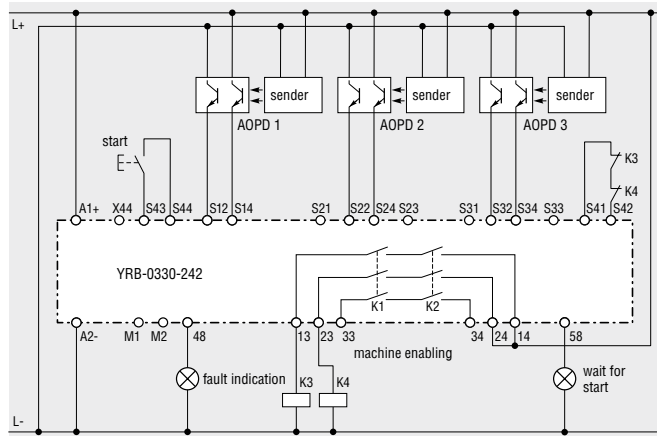

Diagram 1: Protective operation with 3 AOPDs, manual or automatic start, setting with feedback input

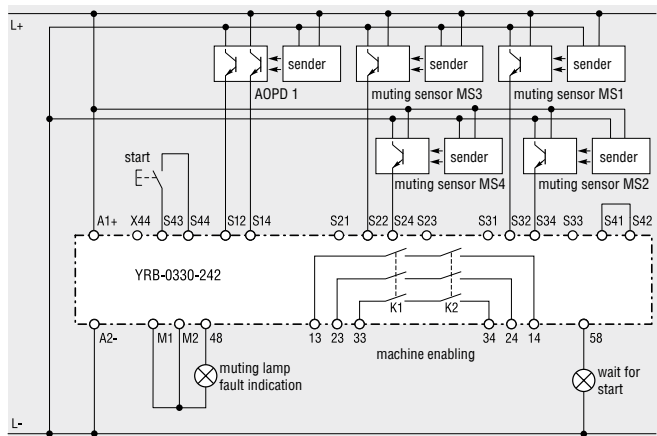

Diagram 2: Protective operation with muting, 4 muting sensors, 1 AOPD

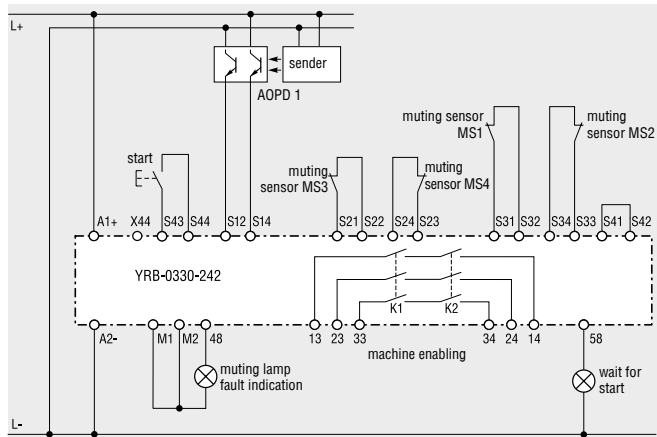

Diagram 3: Protective operation with muting via 4 muting-sensor contacts

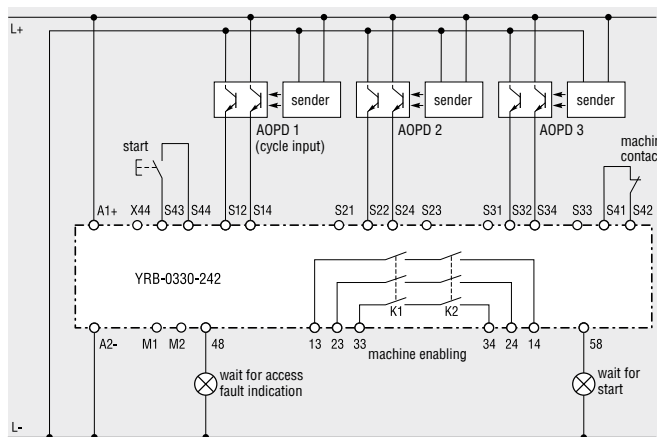

Diagram 4: Stepping operation with 3 AOPDs