

Diagram 1: limit curve for arc-free operation under resistive load

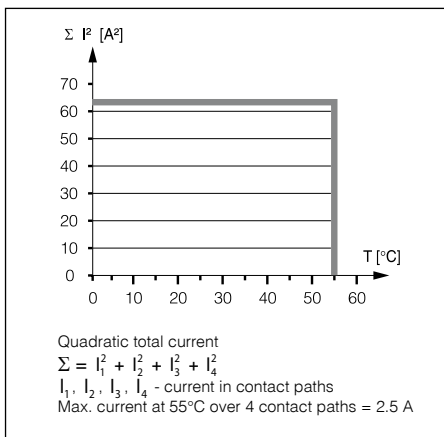
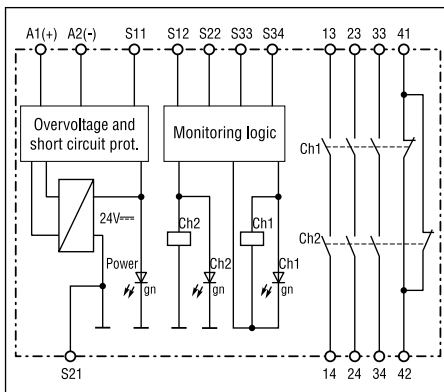

Diagram 2: total current limit curve



Relay block diagram

Wire connection	according to DIN 46 228-1/-2/-3/-4
Screw terminals (integrated)	1 x 4 mm ² solid or 1 x 2.5 mm ² stranded ferruled, or 2 x 1.5 mm ² stranded ferruled, or 2 x 2.5 mm ² solid
Housing material	thermoplastic, meets UL 94V-0
Housing dimensions (W x H x D)	22.5 x 90 x 121 mm
Mounting	on DIN rail (IEC/EN 60715)
Weight	210 g

PART REFERENCE

Safety relay	YRB-0131-241
--------------	--------------

MANUAL RESTART MODE (Channel 1)

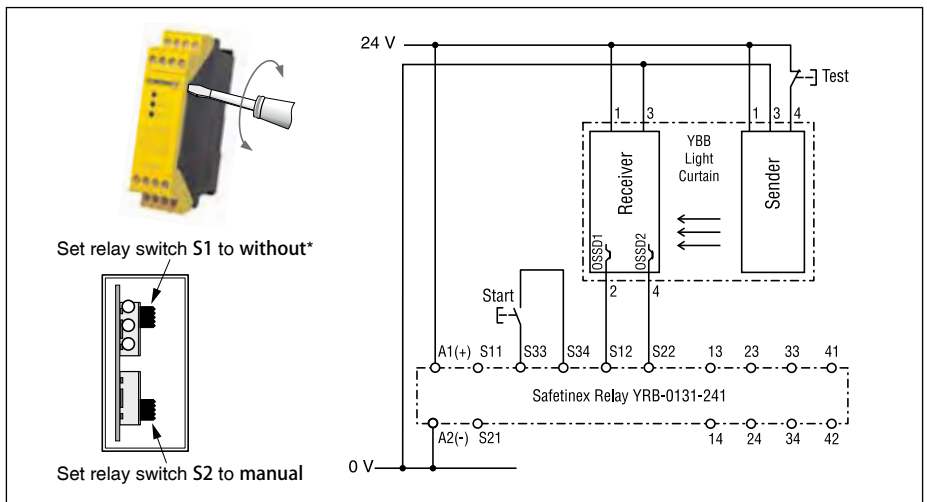

AUTOMATIC RESTART MODE (Channel 1)

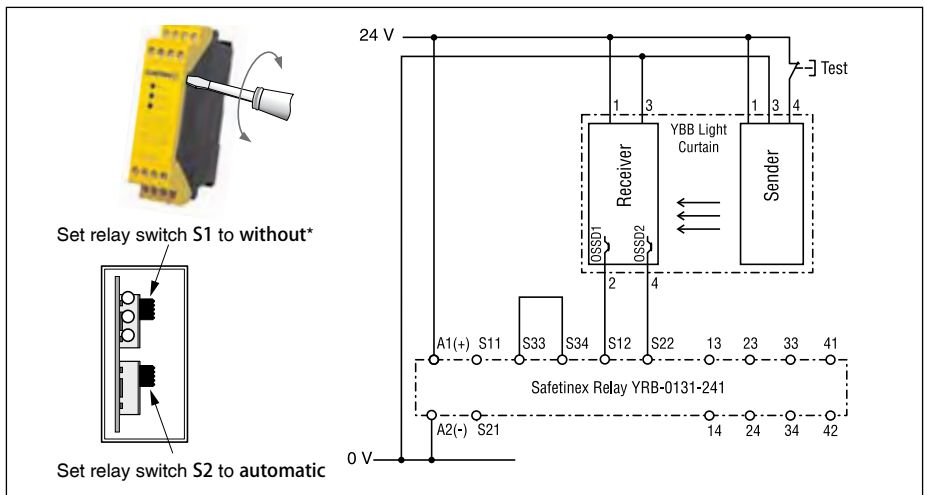

* Position of switch S1:

- With symmetric outputs on light curtain (such as Safetinx YBB type), set switch S1 to "without".
- With asymmetric outputs on light curtain, set switch S1 to "with".