

Ultrasonic proximity switches



Highlights:

- Ready-to-connect compact devices
- Short housing lengths
- Adjustment by means of teach-in, potentiometer and/or interface
- Devices with analog output
- Devices with 2 outputs

CONTRINEX

Ultrasonic proximity switches



Operating principle

Ultrasonic proximity switches can be used as contact-free sensors in many areas of automation. They are employed wherever distances have to be measured in air, since they not only detect objects, but they can also indicate and evaluate the absolute distance between themselves and the target. Changing atmospheric conditions, (e.g. temperature variations) are compensated during evaluation of the measurement.

Ultrasonic proximity switches send out ultrasonic impulses in cyclical intervals. If these are reflected by an object, the resulting echo is received and converted into an electrical signal. Detection of the received echo is dependent on its intensity, itself dependent on the distance of the object from the sensor. The devices function according to the echo-delay principle, i.e. the time delay between the emitter and echo impulses is evaluated.

Sensing range

Due to the sensor construction, the ultrasound is radiated in a lobar shape. Only reflecting objects within this sound beam are detected. Echoes in the blind zone between the sensor face and the sensing range cannot be evaluated.

Targets

The targets to be detected can be in the solid, liquid, granular or powder state. The material may be transparent or colored, of any shape, and with a polished or matt surface. All even or flat surfaces up to an angular deviation of approximately 3° from perpendicular to the sound beam can be detected with certainty, even at the maximum operating distance. Depending on surface roughness, the angular deviation may even be greater. In principle, targets can enter the sound beam from any direction.

Temperature compensation

The ultrasonic proximity switches are equipped with temperature sensors and a compensation circuit, in order to be able to compensate for changes in operating distance caused by temperature fluctuations.

Environmental conditions

Normal atmospheric variations at any given location have a negligible influence on the speed of sound. The propagation of ultrasonic waves in a vacuum is not possible.

High-temperature objects (e.g. red-hot metals) cause air turbulence, dispersing or diverting the ultrasound. In such surroundings, no analyzable echo is produced.

Ultrasonic proximity switches are designed for use under normal atmospheric conditions, i.e. in air. Operation in other gases (e.g. carbon dioxide) can give rise to serious error measurements or even functional failure, due to differing sound speed and damping values.

Normal rain or snowfall does not impair the functioning of ultrasonic proximity switches. The transducer surface should, however, not become moistened, although dew is permissible.

Ambient noise is distinguished from the system's own sound echoes and, as a rule, does not lead to functional errors.

Safety

The use of ultrasonic proximity switches in applications where the safety of people is dependent on their functioning is not permitted.

Available models

Ultrasonic proximity switches from Contrinex are available as diffuse and reflex types.

Diffuse sensors

With diffuse sensors, the target functions as a reflector. As soon as an object enters the preset sensing area, its echo causes the device to switch.

Reflex sensors

In the case of reflex sensors, a fixed reflector (e.g. a small metal plate) is mounted facing the device. The switching range is set to this reflector. If an object comes between the ultrasonic proximity switch and the reflector, the sensor no longer recognizes the latter, which causes the output to switch.

Synchronization

Several devices can be synchronized with each other by simply connecting their synchronization outputs (pin 2 for N.O., pin 4 for N.C.). In this way, up to 10 devices can be synchronized. In many cases, it is thus possible to mount the sensors very close to one another without mutual interference.

The fourth connection can be used as an external release input. Thus, ultrasonic proximity switches can be activated or deactivated with an external control, without switching the supply voltage on and off. An external multiplex operation can be achieved by switching the ultrasonic proximity switches on and off one after the other via the release input. In this case, assurance is always given that the ultrasonic proximity switches do not influence one another. As opposed to internal synchronization, here more than 10 switches can be operated.

Programming

For optimum adaptation to the application conditions, all the devices in this catalog (excepting series 1180/1181C and 1180/1181W) can be programmed with the PC interface device APE-0000-001 (see Accessories, p. 14).

The series 1180/1181C and 1180/1181W devices are adjustable by teach-in via the device connection.

Mounting

Ultrasonic proximity switches can be operated in any installation position. However, positions in which materials can be deposited on the transducer surface should be avoided.

In order to obtain the best reflection results, the ultrasonic proximity switch should be oriented in such a way that the sound waves strike the target at as close to 90° as possible. If this is not possible (e.g. with bulk materials), the maximum possible range has to be determined experimentally, and is dependent on the material, surface and orientation of the objects.

At a glance

- Ready-to-connect compact devices
- Short cylindrical housings of 63.5 mm (connector models)
- High excess gain, therefore insensitive to dirt and ambient noise
- Detection independent of target's color, shape, material and surface structure
- Reduced blind zone
- Low current drain
- Adjustment by means of external teach-in
- Diffuse sensors feature background suppression
- High degree of protection: IP 67

Construction

The devices are built into nickel-plated brass housings, and fully encapsulated in polyurethane. The transducer surface is of epoxy resin and its enclosure of glass-fiber reinforced PBTP / polybutyleneterephthalate (Crastin).

Sensitivity setting

Sensitivity can be adjusted by means of teach-in via the device connection. The lack of a potentiometer prevents the adjustment from being willfully changed.

Technical data:

(according to IEC 60947-5-2)

Supply voltage range U_B	20 ... 30 VDC
Max. ripple content	10 %
Output current	150 mA max.
Output voltage drop	2.0 V max. at 150 mA
Ambient temp. range	-25 ... +70 °C
Degree of protection	IP 67
EMC protection:	
IEC 61000-4-2	4 kV
IEC 61000-4-3	10 V/m
IEC 61000-4-4	2 kV
IEC 61000-4-6	10 V
EN 55011	Class B

Protection

The switches are protected against overloads, short-circuits and wire reversals. Furthermore, protection against temporary overvoltages of the power supply is built-in.

LED

The yellow LED lights up when the output is switched. In teach mode, the LED flashes.

Connection

Devices with 4-pole S12 connector are standard.

Power-ON reset

Operation of the output is inhibited until the power supply requirements are met. This prevents unwanted switching of the output during power-ON. All devices shown here feature power-ON reset.

Data sheets

Detailed data sheets with additional technical information are available for all models. These may be retrieved from the CONTRINEX website (www.contrinex.com), or ordered cost-free from our sales offices.

Drawings

The mechanical drawings may be downloaded as data files from the CONTRINEX website, and imported directly into construction drawings.

Delivery package

Ultrasonic proximity switch, 2 fixing nuts, instructions.

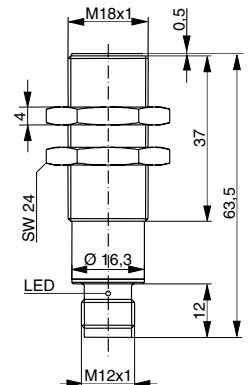

M18

Diffuse sensor with background suppression
30 ... 200 mm



Sensing range	30 ... 200 mm
Setting range	50 ... 200 mm
Tolerance width	-----
Standard target	20 x 20 mm
Hysteresis	10 mm
No-load supply current	max. 20 mA
Rated ultrasonic frequency	400 kHz
Switching frequency	10 Hz
Time delay before availability	20 msec
Response time	50 msec
Weight	30 g
Part references:	
PNP N.O. / connector S12	UTS-1180C-303
Connector type (see page 15)	A
Wiring diagram (see page 15)	1

1180/1181C WITH TEACH-IN

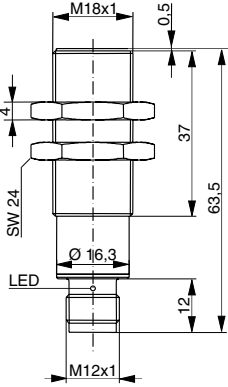
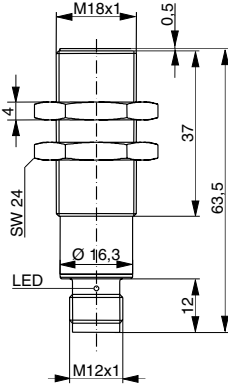
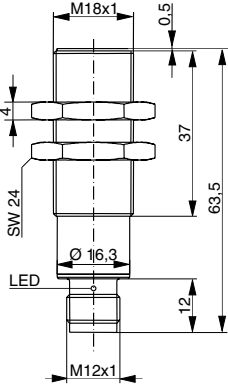
M18	M18	M18	
Reflex sensor 0 ... 200 mm	Diffuse sensor with back-ground suppression 100 ... 700 mm	Reflex sensor 0 ... 700 mm	
			
			
0 ... 200 mm	100 ... 700 mm	0 ... 700 mm	
120 ... 220 mm	150 ... 700 mm	350 ... 750 mm	
20 mm	-----	50 mm	
20 x 20 mm	20 x 20 mm	20 x 20 mm	
2 mm	10 mm	3 mm	
max. 20 mA	max. 20 mA	max. 20 mA	
400 kHz	200 kHz	200 kHz	
10 Hz	5 Hz	5 Hz	
20 msec	20 msec	20 msec	
50 msec	100 msec	100 msec	
30 g	30 g	30 g	
URS-1180C-303	UTS-1181C-303	URS-1181C-303	
A	A	A	
1	1	1	

At a glance

- Ready-to-connect compact devices
- Right-angle sensing
- Robust and fully integrated sensing head
- High excess gain, therefore insensitive to dirt and ambient noise
- Detection independent of target's color, shape, material and surface structure
- Reduced blind zone
- Low current drain
- Adjustment by means of external teach-in
- Diffuse sensors feature background suppression
- High degree of protection: IP 67

Construction

The devices are built into nickel-plated brass housings, and fully encapsulated in polyurethane. The transducer surface is of epoxy resin and its enclosure of glass-fiber reinforced PBTP / polybutyleneterephthalate (Crastin).

Sensitivity setting

Sensitivity can be adjusted by means of teach-in via the device connection. The lack of a potentiometer prevents the adjustment from being willfully changed.

Protection

The switches are protected against overloads, short-circuits and wire reversals. Furthermore, protection against temporary overvoltages of the power supply is built-in.

LED

The yellow LED lights up when the output is switched. In teach mode, the LED flashes.

Connection

Devices with 4-pole S12 connector are standard.

Power-ON reset

Operation of the output is inhibited until the power supply requirements are met. This prevents unwanted switching of the output during power-ON. All devices shown here feature power-ON reset.

Data sheets

Detailed data sheets with additional technical information are available for all models. These may be retrieved from the CONTRINEX website (www.contrinex.com), or ordered cost-free from our sales offices.

Drawings

The mechanical drawings may be downloaded as data files from the CONTRINEX website, and imported directly into construction drawings.

Delivery package

Ultrasonic proximity switch, 2 fixing nuts, instructions.

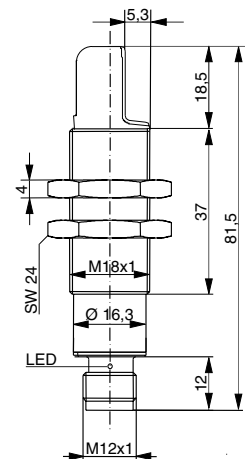

M18

Diffuse sensor with background suppression
30 ... 200 mm



Sensing range	30 ... 200 mm
Setting range	50 ... 200 mm
Tolerance width	-----
Standard target	20 x 20 mm
Hysteresis	10 mm
No-load supply current	max. 20 mA
Rated ultrasonic frequency	400 kHz
Switching frequency	10 Hz
Time delay before availability	20 msec
Response time	50 msec
Weight	30 g
Part references:	
PNP N.O. / connector S12	UTS-1180W-303
Connector type (see page 15)	A
Wiring diagram (see page 15)	1

1180/1181W WITH TEACH-IN

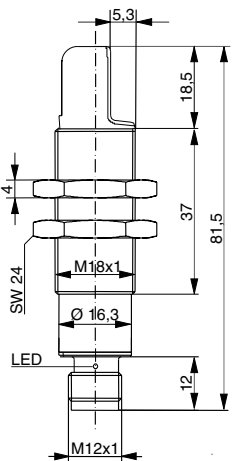
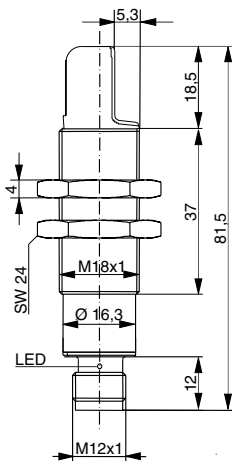
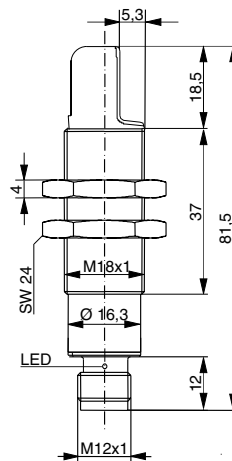
M18	M18	M18	
Reflex sensor 0 ... 200 mm	Diffuse sensor with back-ground suppression 100 ... 700 mm	Reflex sensor 0 ... 700 mm	
			
			
0 ... 200 mm	100 ... 700 mm	0 ... 700 mm	
120 ... 220 mm	150 ... 700 mm	350 ... 750 mm	
20 mm	-----	50 mm	
20 x 20 mm	20 x 20 mm	20 x 20 mm	
2 mm	10 mm	3 mm	
max. 20 mA	max. 20 mA	max. 20 mA	
400 kHz	200 kHz	200 kHz	
10 Hz	5 Hz	5 Hz	
20 msec	20 msec	20 msec	
50 msec	100 msec	100 msec	
30 g	30 g	30 g	
URS-1180W-303	UTS-1181W-303	URS-1181W-303	
A	A	A	
1	1	1	

At a glance

- Ready-to-connect compact devices
- Can be operated as diffuse or reflex sensors (with interface)
- High excess gain, therefore insensitive to dirt and ambient noise
- Detection independent of target's color, shape, material and surface structure
- Reduced blind zone
- Low current drain
- Adjustment by means of potentiometer (only devices with switching output) and interface device APE-0000-001
- Switching or analog output
- Fore- and background suppression
- Diffuse sensors with window function
- High degree of protection: IP 67

Construction

The devices are built into nickel-plated brass housings, and fully encapsulated in polyurethane. The transducer surface is of epoxy resin and its enclosure of glass-fiber reinforced PBTP / polybutyleneterephthalate (Crastin).

Sensitivity setting

Sensitivity is adjusted by means of an interface device (see Accessories, p.14) or potentiometer (only devices with switching output).

Protection

The switches are protected against overloads, short-circuits and wire reversals. Furthermore, protection against temporary overvoltages of the power supply is built-in.

LED

The yellow LED lights up when the output is switched. Flashing LED indicates misadjustment.

Connection

Devices with 4-pole S12 connector are standard.

Power-ON reset

Operation of the output is inhibited until the power supply requirements are met. This prevents unwanted switching of the output during power-ON. All devices shown here feature power-ON reset.

Data sheets

Detailed data sheets with additional technical information are available for all models. These may be retrieved from the CONTRINEX website (www.contrinex.com), or ordered cost-free from our sales offices.

Drawings

The mechanical drawings may be downloaded as data files from the CONTRINEX website, and imported directly into construction drawings.

Delivery package

Ultrasonic proximity switch, 2 fixing nuts, instructions.

M18

Diffuse and reflex sensor
50 ... 300 mm

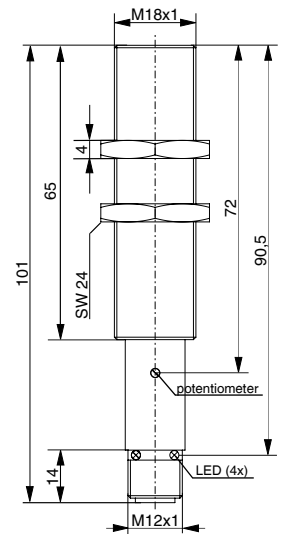

Technical data:

(according to IEC 60947-5-2)

Supply voltage range U_B	12 ... 30 VDC*
Max. ripple content	10 %
Output current	150 mA max.
Output voltage drop	3.0 V max. at 150 mA
Ambient temp. range	-25 ... +70 °C
Degree of protection	IP 67
EMC protection:	
IEC 61000-4-2	4 kV
IEC 61000-4-3	10 V/m
IEC 61000-4-4	2 kV
IEC 61000-4-6	10 V
EN 55011	Class B

* At 12 ... 20 V, approx. 20 % reduced sensing range.

Sensing range	50 ... 300 mm
Setting range	70 ... 300 mm
Standard target	10 x 10 mm
Hysteresis	10 mm
No-load supply current	max. 50 mA
Rated ultrasonic frequency	400 kHz
Switching frequency	5 Hz
Time delay before availability	280 msec
Response time	100 msec
Weight	50 g
Part references:	
PNP N.O. / connector S12	UTS-1180-303
Analog 4 ... 20 mA / connector S12	
Connector type (see page 15)	A
Wiring diagram (see page 15)	2

M18

M18

M18

Diffuse and reflex
sensor
150 ... 1000 mm

Diffuse and reflex
sensor
50 ... 300 mm

Diffuse and reflex
sensor
150 ... 1000 mm

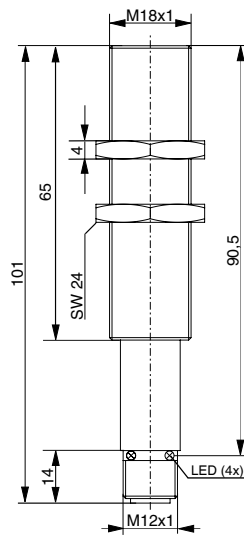
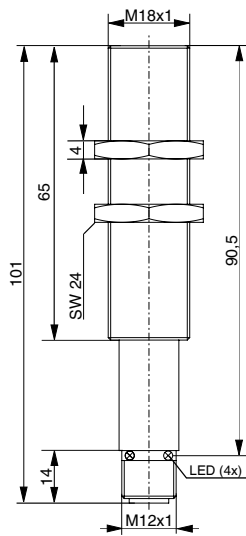
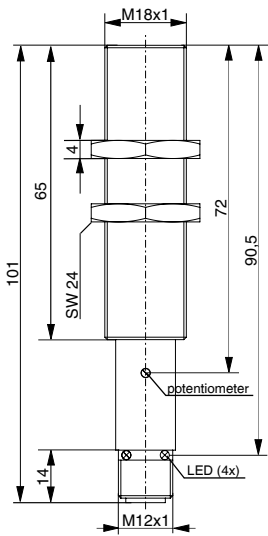

150 ... 1000 mm

170 ... 1000 mm

20 x 20 mm

10 mm

max. 50 mA

200 kHz

4 Hz

280 msec

120 msec

50 g

50 ... 300 mm

70 ... 300 mm

10 x 10 mm

10 mm

max. 50 mA

400 kHz

280 msec

100 msec

50 g

150 ... 1000 mm

170 ... 1000 mm

20 x 20 mm

10 mm

max. 50 mA

200 kHz

280 msec

120 msec

50 g

UTS-1181-303

UTS-1180-329

UTS-1181-329

A

2

A

2

A

2

At a glance

- Ready-to-connect compact devices
- Can be operated as diffuse or reflex sensors
- High excess gain, therefore insensitive to dirt and ambient noise
- Detection independent of target's color, shape, material and surface structure
- Reduced blind zone
- Low current drain
- Adjustment by means of potentiometers and interface device APE-0000-001
- 1 or 2 switching outputs
- Fore- and background suppression
- Diffuse sensors with window function
- High degree of protection: IP 65

Construction

The devices are built into nickel-plated brass housings, and fully encapsulated in polyurethane. The transducer surface is of epoxy resin and its enclosure of glass-fiber reinforced PBTP / polybutyleneterephthalate (Crastin).

Sensitivity setting

Sensitivity is adjusted by means of an interface device (see Accessories, p.14) or potentiometers.

Protection

The switches are protected against overloads, short-circuits and wire reversals. Furthermore, protection against temporary overvoltages of the power supply is built-in.

LED

The yellow LED lights up when the output is switched. Flashing LED indicates misadjustment.

Connection

Devices with 4-pole (UTS-130#-303) or 5-pole (UTS-130#-107) S12 connector are standard.

Power-ON reset

Operation of the output is inhibited until the power supply requirements are met. This prevents unwanted switching of the output during power-ON. All devices shown here feature power-ON reset.

Data sheets

Detailed data sheets with additional technical information are available for all models. These may be retrieved from the CONTRINEX website (www.contrinex.com), or ordered cost-free from our sales offices.

Technical data:

(according to IEC 60947-5-2)

Supply voltage range U_B	12 ... 30 VDC*
Max. ripple content	10 %
Output current	300 mA max.
Output voltage drop	3.0 V max. at 300 mA
Ambient temp. range	-25 ... +70 °C
Degree of protection	IP 65
EMC protection:	
IEC 61000-4-2	4 kV
IEC 61000-4-3	10 V/m
IEC 61000-4-4	2 kV
IEC 61000-4-6	10 V
EN 55011	Class B

* At 12 ... 20 V, approx. 20 % reduced sensing range.

Drawings

The mechanical drawings may be downloaded as data files from the CONTRINEX website, and imported directly into construction drawings.

Delivery package

Ultrasonic proximity switch, 2 fixing nuts, instructions.

M30

Diffuse and reflex sensor
60 ... 300 mm

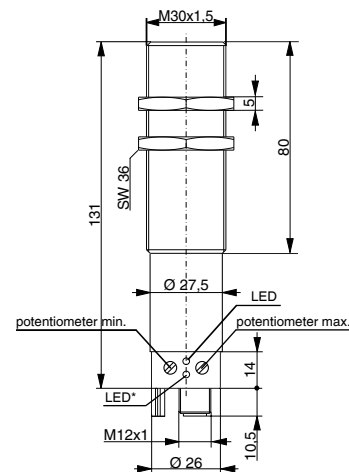

* UTS-130#-107 only

Sensing range	60 ... 300 mm
Setting range	80 ... 300 mm
Standard target	10 x 10 mm
Hysteresis	10 mm
No-load supply current	max. 50 mA
Rated ultrasonic frequency	400 kHz
Switching frequency	8 Hz
Time delay before availability	280 msec
Response time	80 msec
Weight	210 g
Part references:	
1 output: PNP N.O. / connector S12	UTS-1300-303
2 outputs: PNP N.O. / connector S12	UTS-1300-107
Connector types (see page 15)	A (...-303) / B (...-107)
Wiring diagrams (see page 15)	2 (...-303) / 3 (...-107)

1300 ... 1303

M30

Diffuse and reflex
sensor
200 ... 1300 mm



M30

Diffuse and reflex
sensor
400 ... 3000 mm



M30

Diffuse and reflex
sensor
600 ... 6000 mm

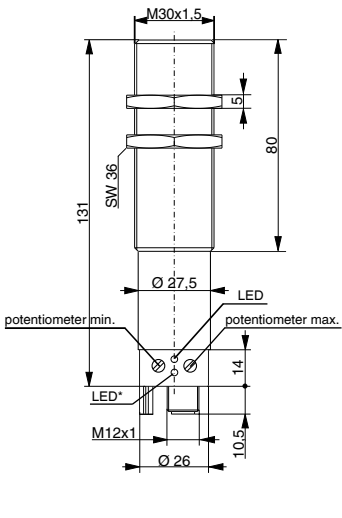

*UTS-130#-107 only

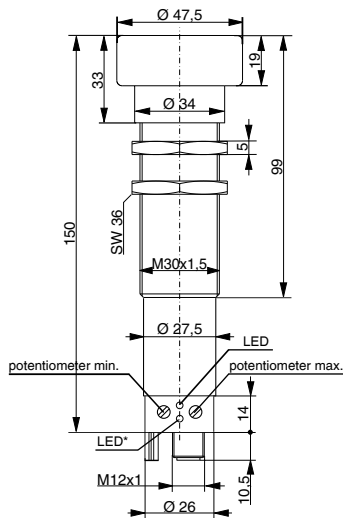

*UTS-130#-107 only

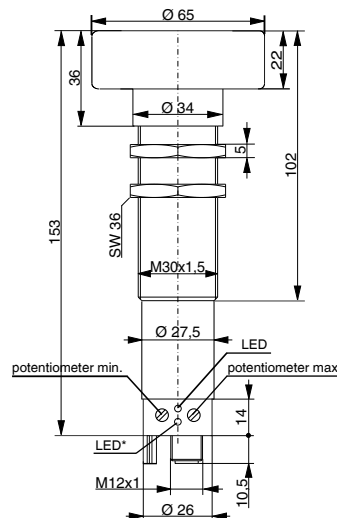

*UTS-130#-107 only

200 ... 1300 mm

220 ... 1300 mm

20 x 20 mm

10 mm

max. 50 mA

200 kHz

4 Hz

280 msec

110 msec

210 g

400 ... 3000 mm

420 ... 3000 mm

50 x 50 mm

20 mm

max. 50 mA

120 kHz

2 Hz

280 msec

200 msec

340 g

600 ... 6000 mm

640 ... 6000 mm

100 x 100 mm

60 mm

max. 50 mA

80 kHz

1 Hz

280 msec

400 msec

380 g

UTS-1301-303

UTS-1301-107

A (...-303) / B (...-107)

2 (...-303) / 3 (...-107)

UTS-1302-303

UTS-1302-107

A (...-303) / B (...-107)

2 (...-303) / 3 (...-107)

UTS-1303-303

UTS-1303-107

A (...-303) / B (...-107)

2 (...-303) / 3 (...-107)

At a glance

- Ready-to-connect compact devices
- Can be operated as diffuse or reflex sensors
- High excess gain, therefore insensitive to dirt and ambient noise
- Detection independent of target's color, shape, material and surface structure
- Reduced blind zone
- Low current drain
- Adjustment by means of potentiometers and interface device APE-0000-001
- Switching and analog outputs
- Fore- and background suppression
- Diffuse sensors with window function
- High degree of protection: IP 65

Construction

The devices are built into nickel-plated brass housings, and fully encapsulated in polyurethane. The transducer surface is of epoxy resin and its enclosure of glass-fiber reinforced PBTP/polybutylene-terephthalate (Cras-tin).

Sensitivity setting

Sensitivity is adjusted by means of an interface device (see Accessories, p.14) or potentiometers.

Protection

The switches are protected against overloads, short-circuits and wire reversals. Furthermore, protection against temporary overvoltages of the power supply is built-in.

LED

The yellow LED lights up when the output is switched. Flashing LED indicates misadjustment.

Connection

Devices with 5-pole S12 connector are standard.

Power-ON reset

Operation of the output is inhibited until the power supply requirements are met. This prevents unwanted switching of the output during power-ON. All devices shown here feature power-ON reset.

Data sheets

Detailed data sheets with additional technical information are available for all models. These may be retrieved from the CONTRINEX website (www.contrinex.com), or ordered cost-free from our sales offices.

Drawings

The mechanical drawings may be downloaded as data files from the CONTRINEX website, and imported directly into construction drawings.

Delivery package

Ultrasonic proximity switch, 2 fixing nuts, instructions.

M30

Diffuse and reflex sensor
60 ... 300 mm

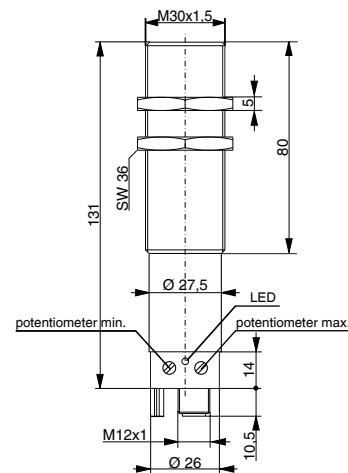

Sensing range	60 ... 300 mm
Setting range	80 ... 300 mm
Standard target	10 x 10 mm
Hysteresis	10 mm
No-load supply current	max. 60 mA
Rated ultrasonic frequency	400 kHz
Switching frequency	5 Hz
Time delay before availability	280 msec
Response time	100 msec
Weight	210 g
Part references:	
Analog 4... 20 mA + PNP N.O. / S12	UTS-1300-123
Analog 0... 10 V + PNP N.O. / S12	UTS-1300-113
Connector type (see page 15)	B
Wiring diagrams (see page 15)	4 (...-123) / 5 (...-113)

1300 ... 1303 WITH ANALOG OUTPUT

M30

M30

M30

Diffuse and reflex
sensor
200 ... 1300 mm

Diffuse and reflex
sensor
400 ... 3000 mm

Diffuse and reflex
sensor
600 ... 6000 mm

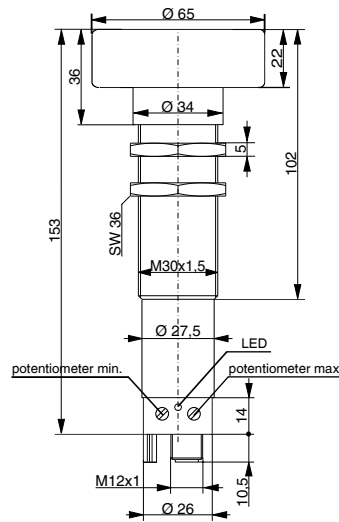
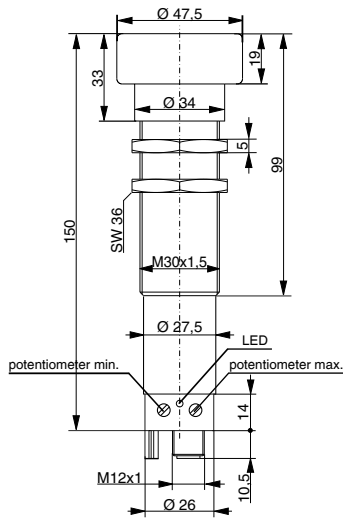
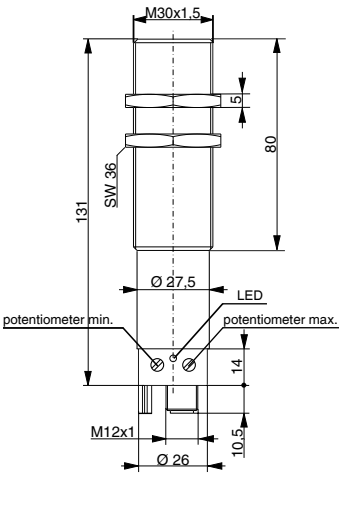

200 ... 1300 mm

400 ... 3000 mm

600 ... 6000 mm

220 ... 1300 mm

420 ... 3000 mm

640 ... 6000 mm

20 x 20 mm

50 x 50 mm

100 x 100 mm

10 mm

20 mm

60 mm

max. 60 mA

max. 60 mA

max. 60 mA

200 kHz

120 kHz

80 kHz

4 Hz

2 Hz

1 Hz

280 msec

280 msec

280 msec

120 msec

200 msec

400 msec

210 g

340 g

380 g

UTS-1301-123

UTS-1302-123

UTS-1303-123

UTS-1301-113

UTS-1302-113

UTS-1303-113

B

B

B

4 (...-123) / 5 (...-113)

4 (...-123) / 5 (...-113)

4 (...-123) / 5 (...-113)

Accessories

CONPROG PC interface

For optimum adaptation to the application conditions, the parameters of all the devices in this catalog (excepting series 1180/1181C and 1180/1181W) can be programmed, visualized, checked and changed with the PC interface device APE-0000-001 and its software CONPROG. Amongst others, the following parameters can be set:

- Beginning and end of operating range
- Hysteresis
- End of sensing range
- Switching function (N.O. or N.C.)
- Beginning and end of analog characteristic curve (devices with analog output)
- Direction of analog characteristic curve (rising or falling)
- End of blind zone
- Mean value generation
- Temperature compensation
- Multiplex function
- Function as diffuse or reflex sensor
- Switching frequency
- Damping (sensitivity)

The programmed values can be stored and printed, thus simplifying the maintenance and documentation of the installation. In case several sensors need to be parametrized identically, the stored setting values can be transferred rapidly to the other sensors by means of the interface device (e.g. when connecting switches in series, or when exchanging them).

The interface device is delivered with a RS232 cable (for serial interface), a mains transformer plug, a sensor connecting cable and CONPROG PC software for Windows. Updates to the latest software version can be downloaded from the CONTRINEX website (www.contrinex.com).

Interface device

suitable for all the devices in this catalog, excepting series 1180/1181C and 1180/1181W.

Part reference: **APE-0000-001**



CONPROG PC software

for Windows.

Included with APE-0000-001 interface device.

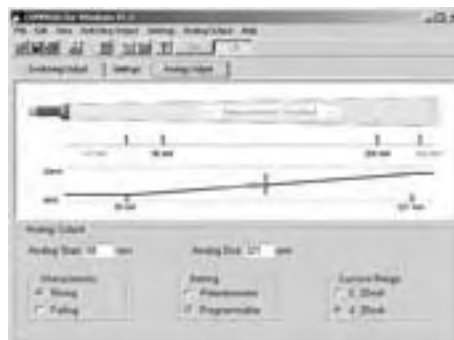

Wiring diagrams

PNP N.O. output with teach-in

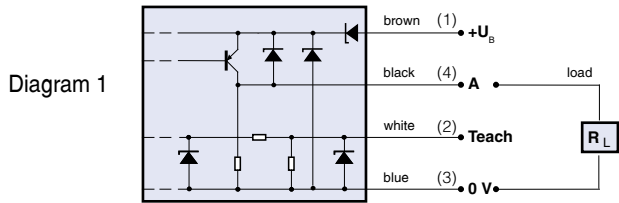

PNP N.O. output / Analog output (current)

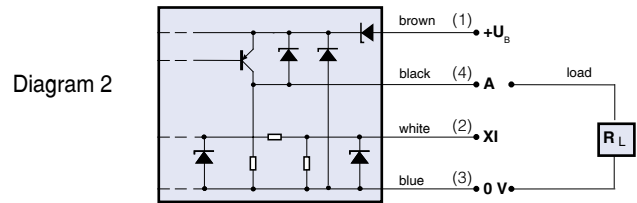

PNP 2 N.O. outputs

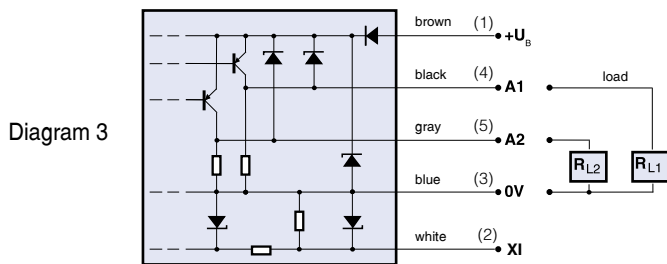

PNP N.O. + analog outputs (current)

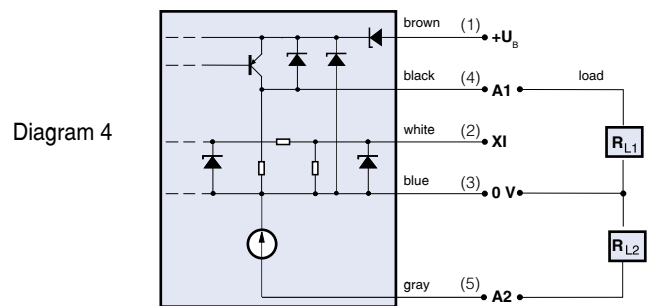

PNP N.O. + analog outputs (voltage)

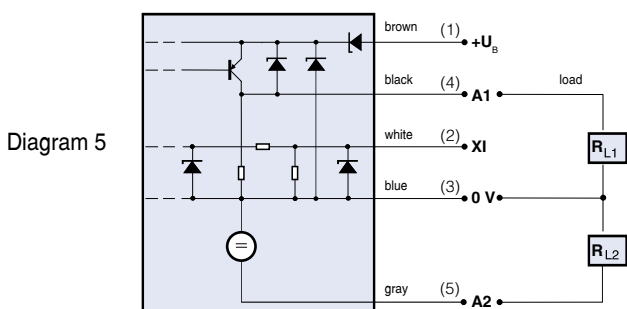

Connector types

