

Model 3040 shown above;
Model 3045 shown on right.



3040 SERIES PANIC SWITCH

Model numbers:
3040, 3045, 3050, 3055

- **Easy installation**
- **Latching LED and non-LED models available**
- **3050 and 3055 feature glowing LED for low light visibility**

The **Sentrol 3040 Series Panic Switch** activates the SPDT switch (SPST on the 3045 model) when the user pulls the actuating lever. On the 3040 model, an external LED lights and latches, indicating that the alarm circuit has been activated. The lever is closed first to rearm the alarm switch, then the latching LED circuit is reset externally at the host panel. The 3045 model has no LED or latching circuit.

The 3050 and 3055 feature a glowing LED for low light visibility. The LED glows green when powered up, turns red upon activation. The 3050 contains a latching LED, the 3055 is non-latching.

Applications

Mounted out of sight but within easy reach for manual activation, such as under desks or counters in banks, jewelry stores and other facilities where people or property are at risk. The 3045 and 3055 models can be used in residential installations when a panic switch is needed. Models with the LED and latching circuit, can be used as a panic switch in medical care facilities. All models provide low-profile and reliable alarm protection.

continued

Sentrol 3040 Series Panic Switch

Architect and Engineering Specifications

The unit consists of a housing that contains the electrical circuitry and magnetic reed contacts, a cover plate to protect the internal electronics and an actuating lever with an Alnico V magnet installed in a cradle in the lever. When the lever is fully closed, the magnet — in proximity to the reed — triggers the circuit. The alarm occurs when the actuating lever is moved 20° to 45° past the fully closed position (approximately 1" from the fully closed position). On the latching models, an LED on the unit flashes and latches when the lever is opened. It can be reset only at the alarm panel.

The actuating lever, housing and cover plate are made of ABS fire-retardant plastic. Dimensions of the unit are 1.77" W x 2.90" L x 0.76" H (4.50 cm W x 7.37 cm L x 1.93 cm H). The unit has 12 feet of jacket lead. The device mounts to the surface with two No. 6 combo-head screws, 5/8" and 1 1/4". Available in white.

Specifications:

Model 3040, 3050, 3055

Nominal Voltage 12 V DC @ 6 mA
 Current Max 8 mA
 Operational Voltage 7 V DC to 15 V DC
 Temperature Range 0° to 110°F (-17.8°C to 43.3°C)
 Dimensions 1.77" W x 2.90" L x 0.76" H
 (4.50 cm W x 7.37 cm L x 1.93 cm H)
 Weight 1.5 oz.
 Housing Material ABS plastic

Form C: 3040 only

Voltage: 30 V
 DC max. Current: 0.25 A max.
 Power: 3 W max.

Model 3045

Temperature Range -40° to 150°F (-40°C to 65.6°C)
 Dimensions 1.77" W x 2.90" L x 0.76" H
 (4.50 cm W x 7.37 cm L x 1.93 cm H)
 Weight 1.5 oz.
 Housing Material ABS plastic

Form A: 3045 only

Voltage: 100 V DC max.
 Current: 0.5 A max.
 Power: 7.5 W max.

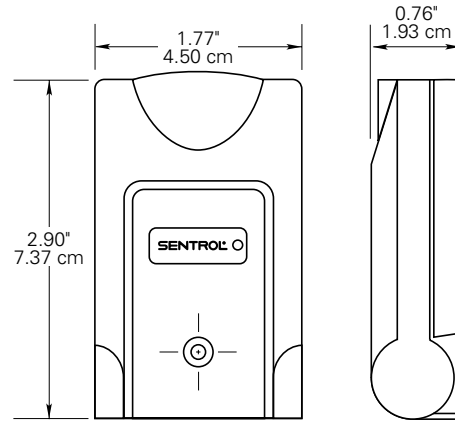

3040, 3050, 3055
 (No LED on 3045)

Ordering Information

| Model Number | LED | Latching Circuit | Electrical Loop Type | Configuration | Color |
|--------------|----------|------------------|----------------------|---------------|-------|
| 3040 | Red | Yes | Open or Closed | SPDT | White |
| 3045 | None | No | Closed | SPST | White |
| 3050 | Bi-color | Yes | Open or Closed | SPDT | White |
| 3055 | Bi-color | No | Open or Closed | SPDT | White |

©1999 Sentrol Certain of the items in the Product Information Bulletin are protected under one or more of the following patents: 4,210,888; 4,210,889; 4,213,110; 4,371,856; 4,325,270; 4,336,518; 4,392,707; 4,456,897; 4,536,754; 4,525,018; 4,553,134; 4,943,791; 5,004,879; 5,155,460; D253,106; D255,030; D,262,618; D268,669; D273,783. Other patents pending.



SENTROL