

# Non-Contact Interlock/Position Switch

## 111 GuardSwitch



### Applications

- Gaming Industry
- Farm Equipment
- Drop Doors
- Emergency Vehicles
- Player Tracking
- Position Sensing
- Bill Validators
- Access Doors

### General Specifications

Enclosure	ABS Plastic
Temperature Range	-40°F to 180°F (-40°C to 80°C)
Environmental	Hermetically Sealed Contact Switch Encapsulated in Polyurethane
NEMA Rating	1, 2, 3, 4, 4x, 5, 6, 12
Protection Class	IP 67
Response Time	1 msec
Life Cycles	100,000 Under Full Load; Up to 200,000,000 Under Dry Circuit
Lead Types/O.D.	18/2 (J) / 0.24" (0.62cm)
UL/CSA	All Models

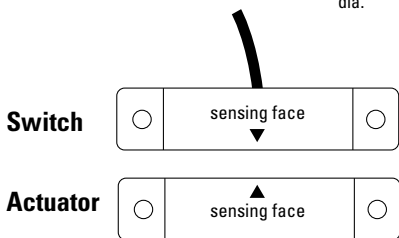
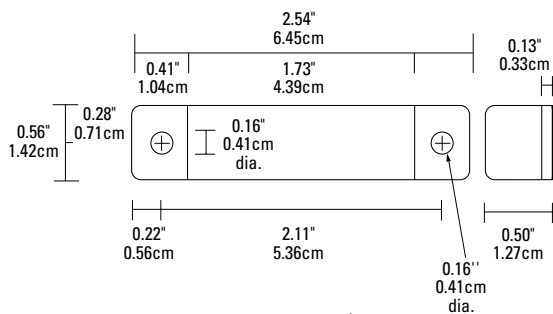

INTERLOCK SWITCH  
100 SERIES



### Order Information

### Electrical Specifications

Part Number	Contact <sup>1</sup> Config.	Load Rating		Switching Voltage, Max.		Switching Current, Max.		Contact Resistance	Sense Range <sup>2</sup> Nominal	Break Range Nominal	Lead Length
		AC	DC	AC	DC	AC	DC				
111-6Y-06J	N.O.	25VA	25W	120V (@0.2A)	120V (@0.2A)	0.7A (@35V)	1.0A (@25V)	0.2 Ohms	1.0" (2.5cm)	2.0" (5.1cm)	6' (1.8m)
111-6Y-12J	N.O.	25VA	25W	120V (@0.2A)	120V (@0.2A)	0.7A (@35V)	1.0A (@25V)	0.2 Ohms	1.0" (2.5cm)	2.0" (5.1cm)	12' (3.6m)
111-7Y-12J	N.O.	100VA	84W	120V (@0.8A)	28V (@3.0A)	3.0A (@34V) <sup>3</sup>	3.0A (@28V) <sup>3</sup>	1.0 Ohms	0.7" (1.8cm)	1.2" (3.0cm)	12' (3.6m)
111-Y	Actuator Only										

**Warning— Each electrical rating is an individual maximum and cannot be exceeded!**

- <sup>1</sup> Configuration with actuator away from the switch
- <sup>2</sup> Proximity of ferrous materials usually reduces sense range — typically by 50%. The shape and type of material cause a wide diversity of effects. Testing is required to determine actual sense range for specific applications.
- <sup>3</sup> Rated at 3.0A for 6,000 cycles only. Other ratings are at 100,000 cycles.