

# Hinge-Operated Safety Switches

## FR 695-1



### Description

GE Interlogix Industrial Hinge Operated Safety Switches utilize a rotating shaft to provide a positive means of turning the control power off should an access panel, door, gate, guard, etc. be rotated open during machine operation.

The switch operating shaft is designed to be in line with the rotation point of the door and uses the opening force of the door to rotate the safety switch operating shaft. When the access panel, door, gate, guard, etc. is rotated to the "open" position, the normally closed contacts in the safety switch are mechanically forced open turning off the control power in the machine—disabling the machine. Since the switch contacts can only be closed when the shaft is rotated to the closed position, the machine cannot be re-started until the door, gate, guard, etc. is closed.

### FR 695-1 / FR 995-1

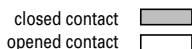
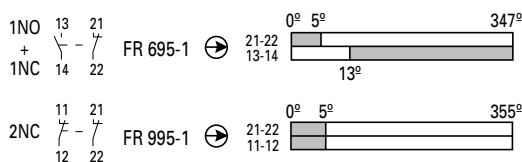
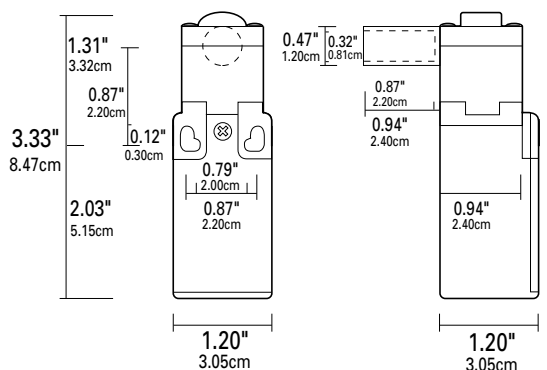

### General Specifications

#### Enclosure

Polymeric glass-reinforced, self-extinguishing, shockproof thermal-plastic providing double insulation

#### Compliance

Low Voltage Directive	73/23/CEE
Directive	93/68/CEE
Machinery Directive	89/392/CEE

#### Conduit entry

One entry	PG 13.5
adapter not furnished	Order PIN IN12135

#### Mechanical endurance

Life Cycle	1 million operations
Operating temperature range	-13° to +175°F (-25° to +80° C)

#### Standards

Safety Switch is in compliance with standards: UL508, CSA C22-2 nr.14, CEI EN 60947-5-1, EN 292, EN 418, EN 1088, EN 60204, EN 60947-5-1, IEC 204, IEC 337-1, IEC 947-5-1, NFC 63-140, VDE 0113, VDE 0660, BG-GS-ET-15. Positive Break Contacts are in compliance with standards: CEI EN 60947-5-1, EN 60947-5-1, IEC 947-5-1, VDE 0660-206.

#### Protection class

IP 65 (according to IEC529)

#### Terminal Screws

Captive with self-lifting pressure plates

#### Door Operating Radius

4° to OPEN the normally closed contact  
8° to CLOSE the normally open contact  
*Switch is in the normal position when the door is CLOSED*

### Order Information

### Electrical Specifications

Model Number	Body Material	Contact <sup>1</sup> Config.	Contact Operating Voltage, Max.	Short Circuit Protection, Max.
FR 695-1	Thermal Plastic	1 N.O. + 1 N.C.	600 VAC, 300 VDC <sup>3</sup>	10A fuse
FR 995-1	Thermal Plastic	2 N.C.	600 VAC, 300 VDC <sup>3</sup>	10A fuse

### Contact rating<sup>2</sup>

UL/CSA	10A A600/Q300 <sup>3</sup>			DC13		
IEC	AC15	500	250	24	125	250
Volts	250	400	500	24	125	250
Current (A)	6	3	1	6	1.1	0.4

**Warning— Each electrical rating is an individual maximum and cannot be exceeded!**

<sup>1</sup> Configuration with door/gate closed

<sup>2</sup> POSITIVE DOUBLE BREAK CONTACTS. Electrically isolated contacts allow different voltages placed on contact poles.

<sup>3</sup> UL508

Figure 1

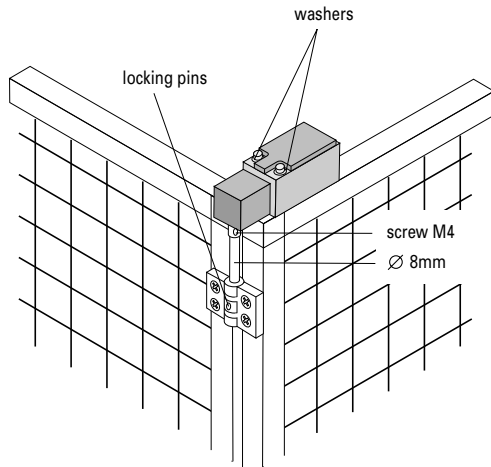
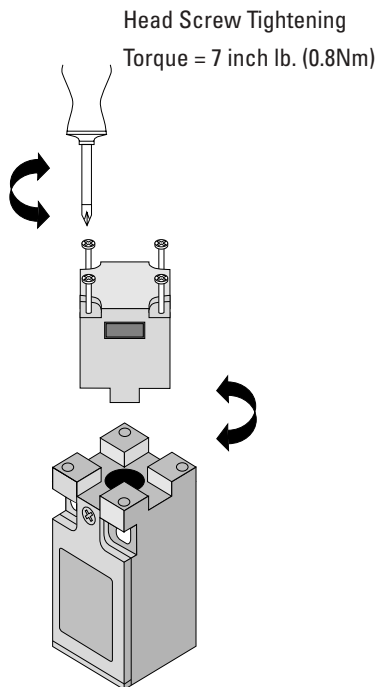

Figure 2



## Installation

1. Safety circuits must be connected to the normally closed (NC) contact (11-12 or 21-22). The normally closed contacts are opened when the door is rotated past 4° and normally open (NO) contacts (13-14) are closed when the switch is rotated past 8°. Normally open contacts are for indicating circuits and are not for use in the safety circuit.
2. Mount the switch using tamper resistant fasteners (not supplied). Always use washers under the switch mounting fasteners to prevent the fasteners from pulling through the switch mounting holes. See figure. 1.
3. The head of the switch can be rotated in 4 x 90 degree steps allowing 4 different shaft rotating positions. To rotate the head, remove the 4 head attachment screws, rotate the head into the proper position, reinsert the head attachment screws. It is recommended the head be locked into position by replacing 2 of the 4 head attachment screws with tamper proof screws (not provided). See figure 2.
4. The switch is to be used with the rotating hinge pin of the door. Attach the Hinge Operated Safety Switch to the machine at the door swing centerline. Extend the door hinge pin into the Hinge Operated Safety Switch operating tube using the M4 set screw provided. Verify operation of the entire assembly including the operating point for the normally closed safety contact and once verified as correct drill a hole through the hinge pin/operating tube assembly to permanently lock the hinge pin into the operating tube using the roll pin provided. See figure 1.
5. Verify proper Safety Switch operation before placing the machine in service. Safety Switches can protect areas where an operator can physically enter.
6. **The switch is not to be used as a mechanical stop.**