



(Shown with straight key)

Key-Operated Safety Switches

FR 692-D / FX 692-D / FD 693-F

Description

GE Interlogix Industrial Key-Operated Safety Switches utilize a removable stainless steel key to provide a positive means of turning the control power off should an access panel, door, gate, guard, etc. be opened during machine operation.

When the key is removed from the switch, the normally closed contacts are mechanically forced open. This opens the safety circuit turning off the control power in the machine— disabling the machine. Since the switch contacts can only be closed when the key is installed in the switch, the machine cannot be re-started until the door, gate, guard, etc. is closed.

General Specifications

Enclosure

FR, FX, FP series	Polymeric glass-reinforced, self extinguishing, shockproof thermal-plastic providing double insulation
FD series	Die cast metal w/ baked epoxy powder coating

Compliance

Low Voltage Directive	73/23/CEE
Directive	93/68/CEE
Machinery Directive	89/392/CEE

Conduit entry

FD, FR series	(One entry)	PG 13.5
FX series	(Two entries)	PG 13.5
Adapter not furnished	Order P/N	IN12135

Mechanical endurance

Life Cycle	1 million operations
Operating temperature range	- 13° to +175°F (-25° to +80° C)
Maximum activating speed	19.5 inches / sec (0.5m/s)
Minimum activating speed	0.039 inches / sec (1mm/s)

Order Information ¹		Electrical Specifications		
Model Number	Body Material	Contact ² Config.	Contact Operating Voltage, Max.	Short Circuit Protection, Max.
FR 692-D1	Thermal Plastic	1 N.O. + 1 N.C.	600 VAC, 300 VDC ⁴	10A fuse
FR 992-D1	Thermal Plastic	2 N.C.	600 VAC, 300 VDC ⁴	10A fuse
FX 692-D1	Thermal Plastic	1 N.O. + 1 N.C.	600 VAC, 300 VDC ⁴	10A fuse
FX 992-D1	Thermal Plastic	2 N.C.	600 VAC, 300 VDC ⁴	10A fuse
FD 693-F1	Die Cast Metal	1 N.O. + 1 N.C.	600 VAC, 300 VDC ⁴	10A fuse
FD 993-F1	Die Cast Metal	2 N.C.	600 VAC, 300 VDC ⁴	10A fuse
FP 693-F1	Thermal Plastic	1 N.O. + 1 N.C.	600 VAC, 300 VDC ⁴	10A fuse
FP 993-F1	Thermal Plastic	2 N.C.	600 VAC, 300 VDC ⁴	10A fuse

Contact rating ³						
UL/CSA	10A A600/Q300 ⁴			DC13		
IEC	AC15			24	125	250
Volts	250	400	500	6	1.1	0.4
Current (A)	6	3	1	6	1.1	0.4

Warning— Each electrical rating is an individual maximum and cannot be exceeded!

¹ Switches are furnished standard with D1 or F1 (90°) key. Other key styles available on Accessories page.

² Configuration with key in

³ POSITIVE DOUBLE BREAK CONTACTS. Electrically isolated contacts allow different voltages placed on contact poles.

⁴ UL508

FR 692-D

FR 992-D

one conduit entry

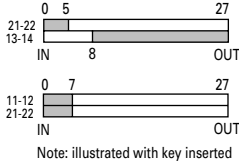
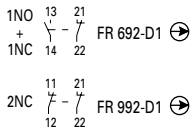
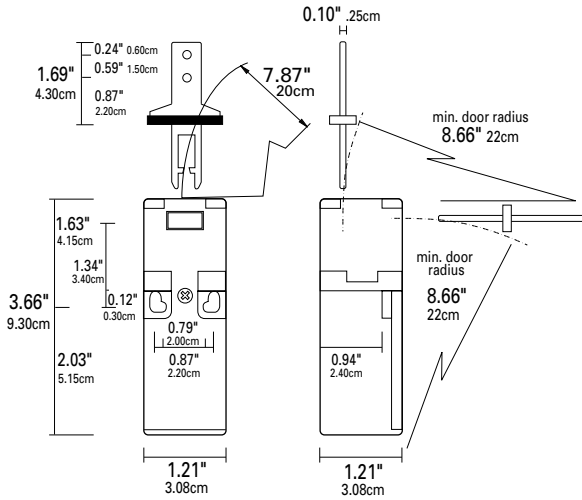

FX 692-D

FX 992-D

two conduit entries

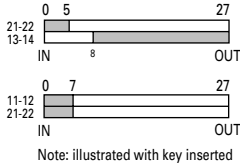
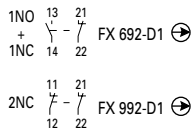
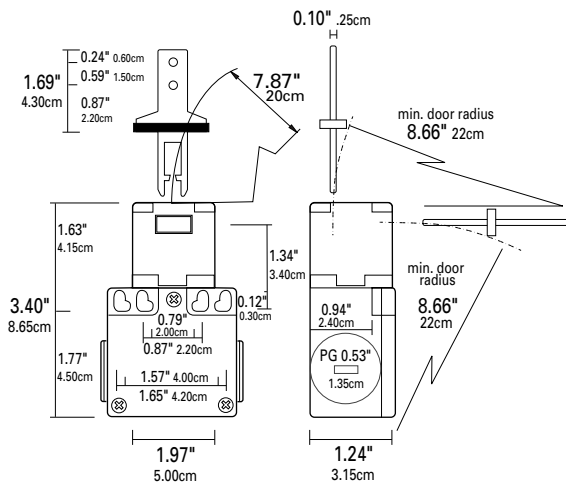

closed contact
 opened contact

General Specifications (continued)

Standards

Safety Switch is in compliance with standards: UL508, CSA C22-2 nr.14, VDE 0113, CEI EN 60947-5-1, EN 292, EN 418, EN 1088, EN 60204, EN 60947-5-1, IEC 204, IEC 337-1, IEC 947-5-1, NFC 63-140, VDE0113, VDE 0660, BG-GS-ET-15. Positive Break Contacts are in compliance with standards: CEI EN60947-5-1, EN 60947-5-1, IEC 947-5-1, VDE 0660-206.

Protection class

FR, FX, FP Series
FD Series

IP 65 (according to IEC529)
IP 66 (according to IEC529)

Terminal Screws

Captive with self-lifting pressure plates
(FR 692-D/FX 69 2-D, FP693-F)

Minimum Door Radius

Side	7.87" (20.0cm)
Front	8.66" (22.0cm) (FD 693-F)
Side	11.8" (30.0cm)
Front	17.7" (45.0cm)

FP 693-F / FP 993-F

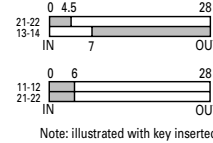
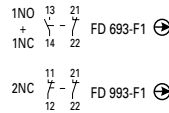
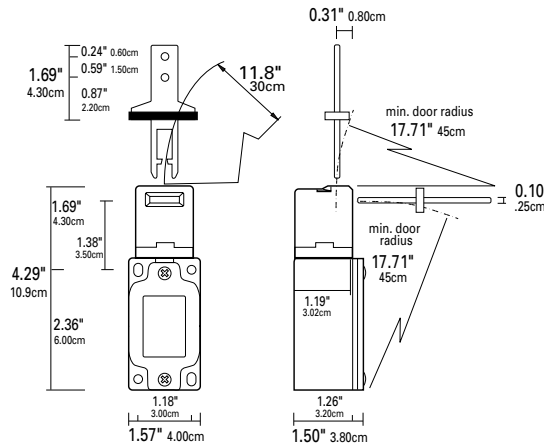

SAFETY MECHANICAL SWITCHES

Figure 1

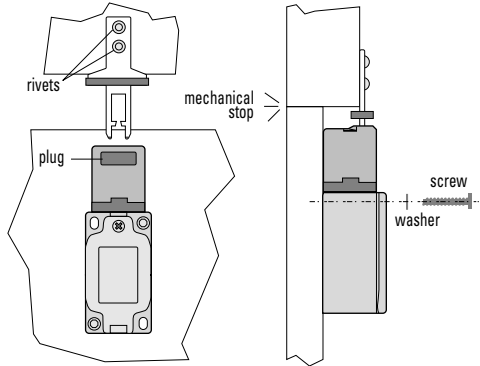
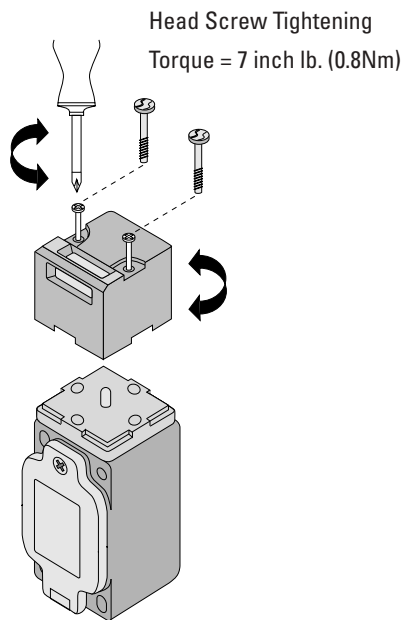

Figure 2



Installation

1. Safety circuits must be connected to the normally closed (NC) contact (11-12 or 21-22). Contacts are normally closed when the key is inserted into the switch. The contacts are opened when the key is removed from the switch. Normally open (NO) contacts (13-14) are for indicating circuits and are not for use in the safety circuit.
2. Mount the switch and key into the machine using tamper resistant fasteners (not supplied). Always use washers under the switch mounting fasteners to prevent the fasteners from pulling through the switch mounting holes. See figure 1.
3. The head of the switch can be rotated in 4 x 90 degree steps allowing 8 different key entry positions. To rotate the head, insert the key, remove the 4 head attachment screws, rotate the head into the proper position, reinsert the head attachment screws. It is recommended the head be locked into position by replacing 2 of the 4 head attachment screws with tamper proof screws (not provided). See figure 2.
4. Always insert the dust protection plug into the unused port in the key head.
5. When the key is removed from the switch, take care to protect the key entrance from dust and dirt.
6. Verify proper Safety Switch operation before placing the machine in service. Key Operated Safety Switches can protect areas where an operator can physically enter.
7. To prevent accidental closing of the door with the operator inside, padlocks can be placed through the hole in the switch key. Minimum diameter of the lock shank is 1/4" (6mm). See Figure 3.
8. **The switch is not to be used as a mechanical stop.**

Figure 3

