

1436/1438 Series Junction Boxes - NEMA 12, 13

Lift Off, Screw Cover



Industrial Enclosures
Junction Boxes



1436 Standard Depth



1438 Extra Depth

Application

- Designed for use as instrument enclosures, electrical junction boxes or terminal wiring enclosures.
- Provides a degree of protection from falling dirt, dust, oil and water.

Standards

- UL 508 Type 12 and 13
- CSA Type 12 and 13
- **Complies with**
 - NEMA Type 12 and 13
 - IEC 529, IP65

Construction

- Formed from 14 gauge steel.
- Smooth, continuously welded seams without knockouts, cutouts or holes.
- Welded brackets provide for enclosure mounting.
- Lift off cover is secured with captive, plated steel screws, and supported on internal hinges except as noted on charts at bottom and right.
- Cover screws fasten into threaded, sealed wells.
- Oil resistant gaskets are permanently secured and mechanically retained.
- A grounding stud is provided in the enclosure.

Finish

- Cover and enclosure are phosphatized and finished in ANSI/ASA 61 gray recoatable powder coating.

Standard Depth Series (1436)

Part No.	Centers					Overall Dimensions		Ship Wt. lbs
	A	B	C	D	E	L	W	
1436A ¹	3.50	3.25	2.75	2.38	4.00	4.50	3.56	2
1436B ¹	5.75	3.25	2.75	2.38	6.25	6.75	3.56	2
1436C ¹	8.00	3.25	2.75	2.38	8.50	9.00	3.56	3
1436D ¹	10.25	3.25	2.75	2.38	10.75	11.25	3.56	4
1436F	7.25	6.25	3.00	5.38	7.75	8.25	6.56	5
1436H	9.50	6.25	3.00	5.38	10.00	10.50	6.56	5
1436K	9.50	8.50	3.00	7.63	10.00	10.50	8.81	7
1436O	11.75	8.50	3.00	7.63	12.25	12.75	8.81	8
1436S	11.75	10.75	3.00	9.88	12.25	12.75	11.06	9
1436V	14.00	10.75	3.00	9.88	14.50	15.00	11.06	11
1436X	14.00	13.00	3.00	12.13	14.50	15.00	13.31	12
1436-30	16.25	13.00	3.00	12.13	16.75	17.25	13.31	14
1436-36	16.25	15.25	3.00	14.38	16.75	17.25	15.56	16
1436-42	18.50	15.25	3.00	14.38	19.00	19.50	15.56	18

¹ Not hinged

1436/1438 Series Junction Boxes - NEMA 12, 13

Lift Off, Screw Cover

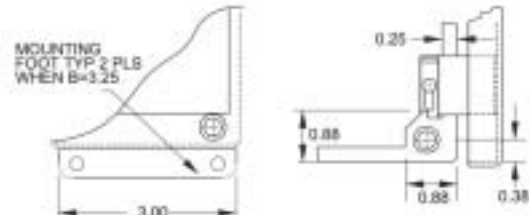
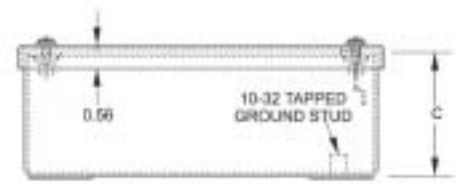
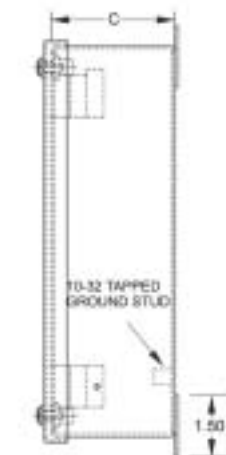
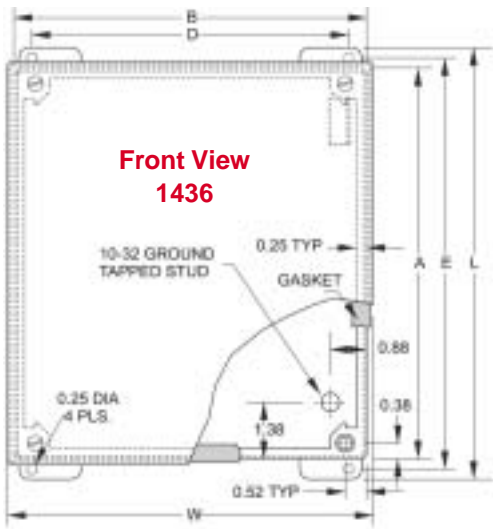

Note: 1436 A,B,C,D not hinged
Retractable pin allows door to be mounted on left or right side.

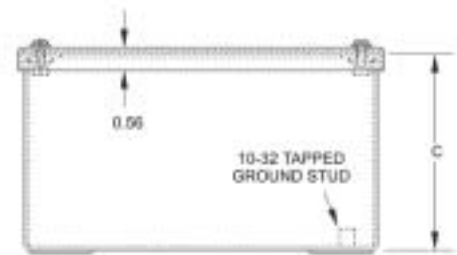
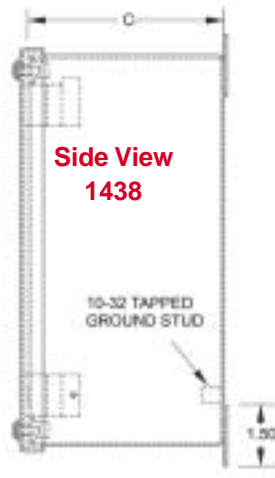
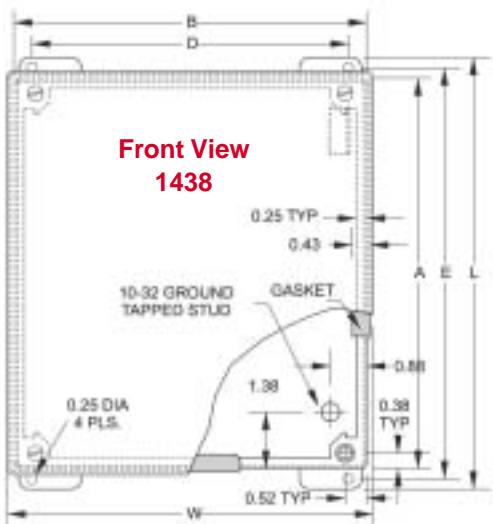

*Note: 1438 A not hinged

**Industrial Enclosures
Junction Boxes**

Extra Deep Series (1438)

Part No.	Centers					Overall Dimensions		Ship Wt. lbs
	A	B	C	D	E	L	W	
1438A ¹	4.00	4.00	4.75	3.13	4.50	5.00	4.31	3
1438B	6.00	4.00	4.75	3.13	6.50	7.00	4.31	4
1438C	8.00	4.00	4.75	3.13	8.50	9.00	4.31	5
1438D	10.00	4.00	4.75	3.13	10.50	11.00	4.31	5
1438F	7.25	6.25	4.75	5.38	7.75	8.25	6.56	5
1438H	9.50	6.25	4.75	5.38	10.00	10.50	6.56	5
1438K	9.50	8.50	4.75	7.63	10.00	10.50	8.81	7
1438O	11.75	8.50	4.75	7.63	12.25	12.75	8.81	8
1438S	11.75	10.75	4.75	9.88	12.25	12.75	11.06	9
1438V	14.00	10.75	4.75	9.88	14.50	15.00	11.06	11
1438X	14.00	13.00	4.75	12.13	14.50	15.00	13.31	12
1438-30	16.25	13.00	4.75	12.13	16.75	17.25	13.31	14
1438-36	16.25	15.25	4.75	14.38	16.75	17.25	15.56	16
1438-42	18.50	15.25	4.75	14.38	19.00	19.50	15.56	18

¹ Not hinged