

Polyester Enclosures - NEMA 4X

PJFS Series - Continuous Hinge Freestanding

Corrosion Resistant Freestanding Enclosures



**Panel
Sold
Separately**



Application

- Designed for use as instrument enclosures, electric, hydraulic or pneumatic control housings, electrical junction boxes or terminal wiring enclosures.
- Provides outstanding insulation and protection where equipment may be hosed down or be very wet.
- Ideal in applications with high temperatures or highly corrosive environments.

Standards

- UL/cUL 508 Type 1, 2, 3, 4, 4X, 12 and 13
- CSA Type 1, 2, 3, 4, 4X, 12 and 13
- **Complies with**
 - NEMA Type 1, 2, 3, 4, 4X, 12 and 13
 - IEC 60529, IP66

Construction

- Fiberglass polyester enclosure with matching door is easily punched, cut, or drilled.
- Enhanced UV inhibitors protect against outdoor weathering.
- Collar Studs are provided for optional inner panel.
- Mounting hardware included.
- Heavy duty continuous 304 SS Hinge.
- Flexible self-gripping gasket compresses over flange for tight seal.
- 3-point SS handle with pad lock provision.
- Molded in drip shield
- Fiberglass mounting strut side walls on double door unit.
- Operating temperatures between 130°C and -40°C (266°F to -40°F).
- Impact index of 6.78J (5 ft/lb).
- For corrosion resistance information, please refer to table in the Technical Information section.

Finish

- Fiberglass polyester material has a gray finish.
- Optional inner panels are available in white powder coated finished steel.

Accessories

- Viewing windows...see page 138

Single Door

Part Number	Height	Width	Depth	Ship Wt (lbs)
PJFS722525	72.0	25.0	24.5	215

Double Door

Part Number	Height	Width	Depth	Ship Wt (lbs)
PJFS724925DD	72.0	48.0	24.5	430

Inner Panel - Painted Steel - Qty 1 Required

Part Number	Height	Width	Finish
18P5721	57.0	21.0	White

Inner Panel - Painted Steel - Qty 2 Required

Part Number	Height	Width	Finish
18P5721	57.0	21.0	White

Polyester Enclosures - NEMA 4X

PJFS Series - Continuous Hinge Freestanding

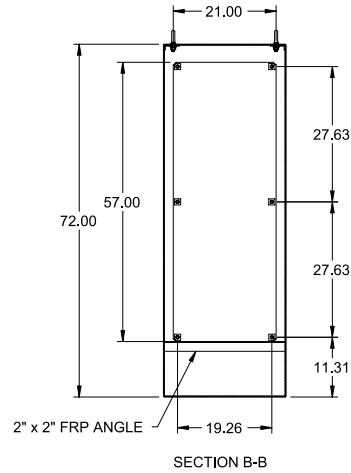
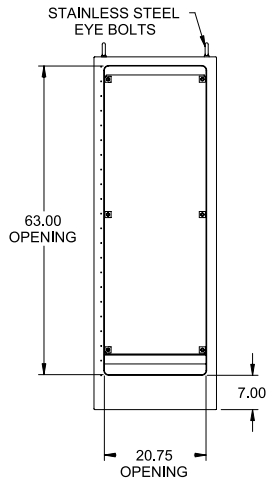
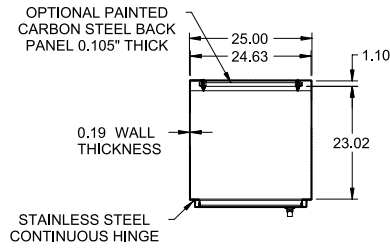
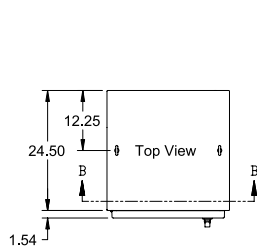

**Front View
(with Single Door Open)**

Internal View

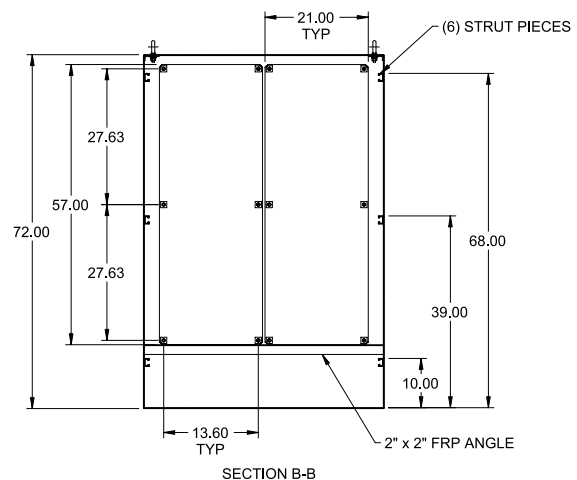
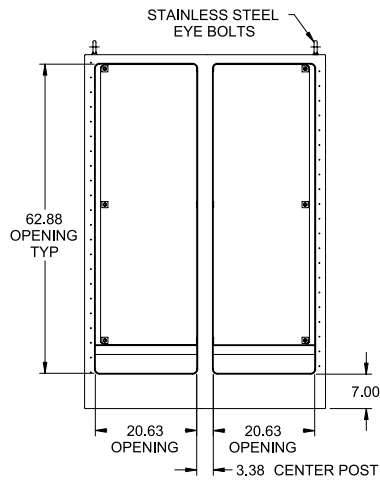
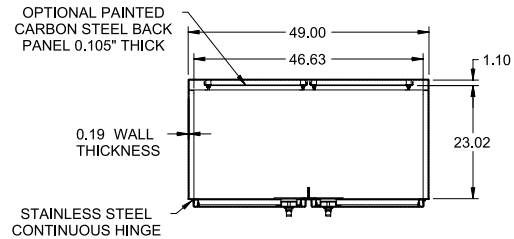
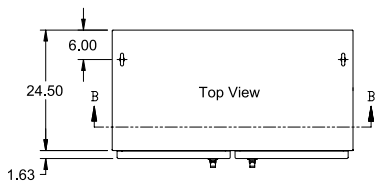

**Front View
(with Double Doors Open)**

Internal View

Corrosion Resistant

Freestanding Enclosures