

# AS-Interface Safety at Work

- NEW** Safety Communication Terminal/Safety Monitor..... 430
- NEW** Emergency Stop Switches ..... 433
- Operating Instructions..... 437



For more information on this product family, visit our website.  
Additional resources include:

- New and updated product information
- Downloadable software demos & upgrades
- Part configuration tool & cross reference
- Online stock check & ordering
- IDEC field sales & distributor search
- Online literature request
- Downloadable manuals & CAD drawings
- Manufacturer's suggested retail price list
- Product training schedule & locations
- Advertising & trade show schedules
- Press releases & FAQs

### AS-Interface Safety at Work

AS-Interface safety at work integrates a safety network into one wire-saving system.

- Safety slaves and safety monitors can be simply connected to the existing AS-Interface network to establish the AS-Interface Safety at Work.
- Interlock switches, safety relay modules and other safety components can be connected to the safety network via safety slaves.
- Emergency stop switches can be connected directly to AS-Interface Safety at Work, further reducing wiring.
- Safety components can be connected to other networks through gateways.

Overview

X Series E-Stops

Door Interlock Switches

Enabling Switches

Barriers

AS-Interface Safety at Work

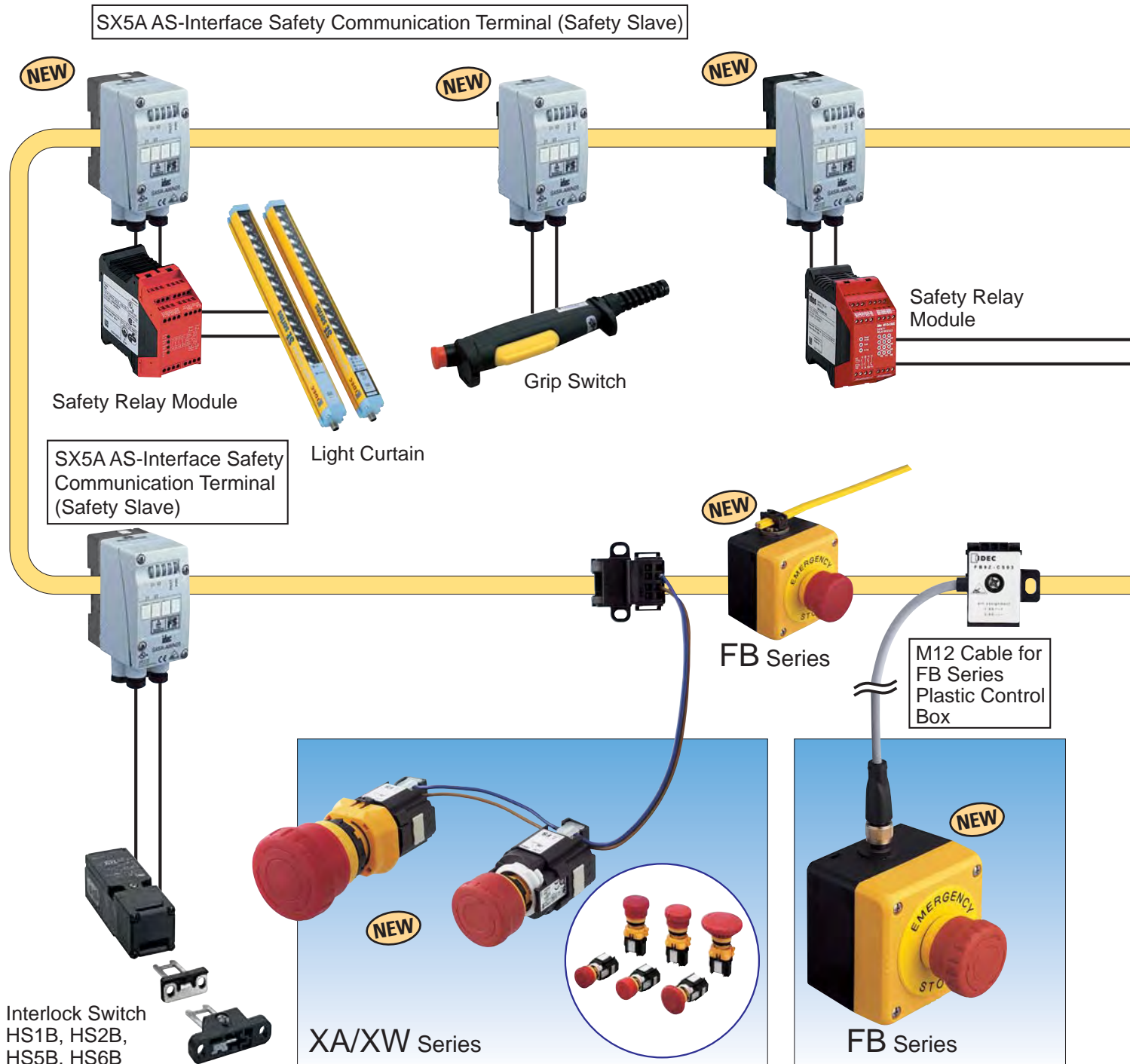

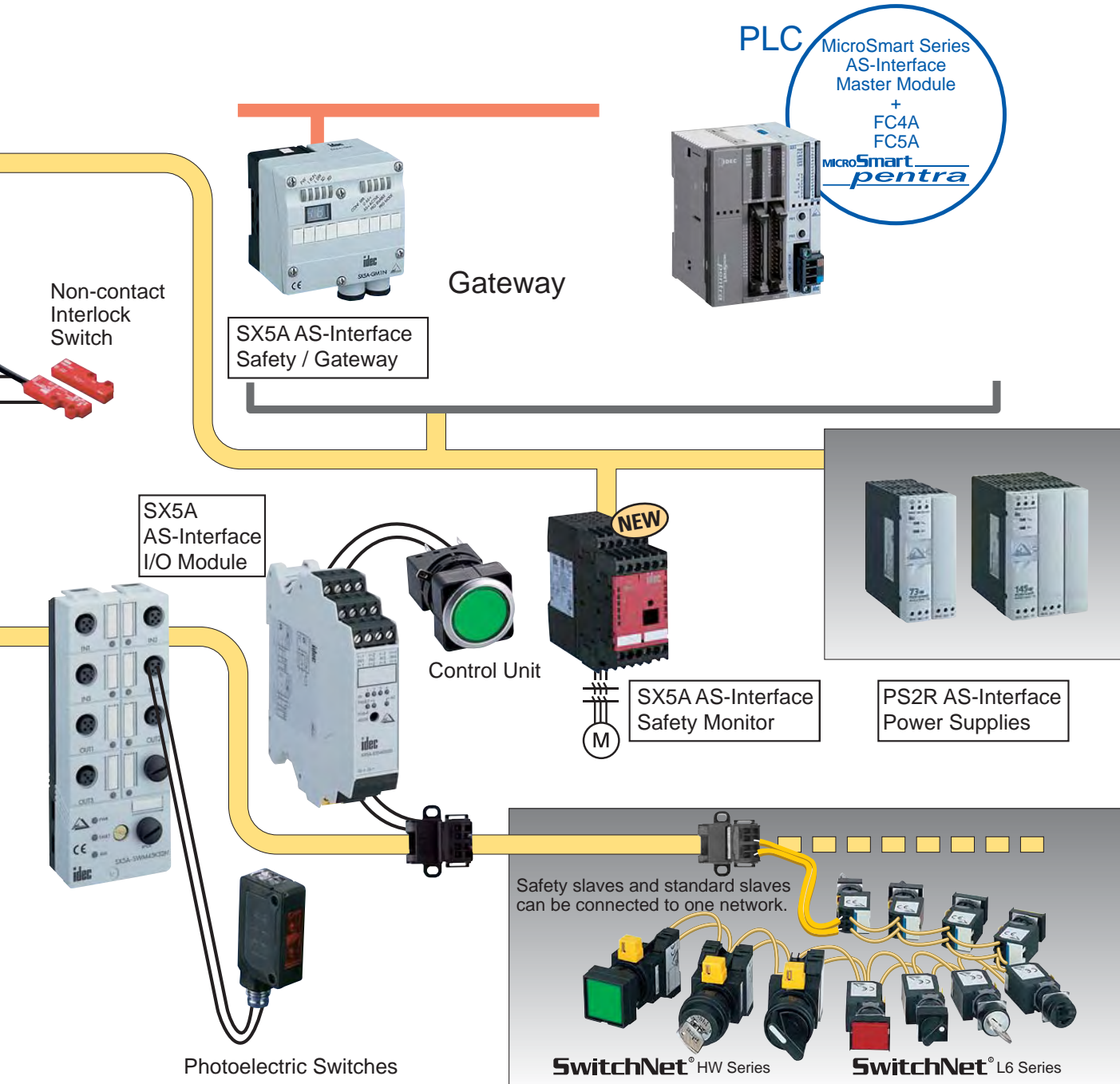

## Safety Communication Terminal/ Safety Monitor

### Reduces Safety Equipment Wiring

- EN954-1 category 4 compliant
- Safety network can be established simply by connecting the safety slave and monitor to the AS-Interface network.
- Standard slaves and safety slaves can be used in the same network, and no new safety network is necessary.
- Response time 40 ms maximum (time interval after the safety input of safety slave has been shut down until the safety output is turned off)
- A maximum of 31 safety slaves can be connected.
- Stop category 0 or 1 can be selected (stop category 0: when a warning signal is input, the safety relay is shut down instantly; stop category 1: when a warning signal is input, the safety relay is shut down after the machine driving part has moved to safe status)
- The setting of safety monitor can be made easily using the AS-Interface safety monitor configuration software on a Windows PC.



AS-Interface Safety Communication Terminal



AS-Interface Safety Monitor



### Part Numbers

#### Unit

Product	Description	Part Number
SX5A AS-Interface Safety Communication Terminal (Safety Slave)	2 inputs (safety input)	SX5A-AWN20
Base Module	Used with AS-Interface safety communication terminal	SX5A-G1FA
SX5A AS-Interface Safety Monitor	2 safety outputs x 2 circuits	SX5A-MBR02

#### Accessories

Product	Description	Part Number
Safety Monitor Configuration Software	CD-ROM	SX9Y-ASMTR
Cable	For connecting the safety monitor and PC	SX9Z-PCCABLE
	For connecting two safety monitors	SX9Z-MTRCABLE



### Specifications

#### SX5A AS-Interface Safety Monitor

<b>Electrical Specifications</b>	Voltage	24V DC ±15%
	Current	200 mA
	Response Time	<40 msec
	Startup Delay Time	<10s
<b>AS-Interface Communication Specifications</b>	Profile	Monitor 7.F
	ID Code	F
	IO Code	7
	Voltage	18.5 to 31.6V
	Current	45 mA
<b>Configuration Interface Specifications</b>	Interface	RS232C
	Communication Speed	9600 bps, No parity, 1 start bit, 1 end bit, 8 data bits
<b>Input</b>	Start Input	Photocoupler input: High active approx. 10 mA (24V DC)
	External Device Monitor Input	

<b>Output</b>	Message Output (safety on)	PNP transistor output 200 mA Short-circuit/reverse connection protection
	Safety Output	2NO contacts x 2 circuits Maximum contact load AC-15: 230V AC, 3A, DC-13: 24V DC, 1A Continuous current: 3A per circuit
	Fuse	Maximum 4A slow-blow type (external)
	Overvoltage Category	3 (complies with rated operating voltage 300V AC, VDE0110)
<b>Environment Specifications</b>	Operating Temperature	-20 to +60°C (no freezing)
	Storage Temperature	-30 to +70°C (no freezing)
	Degree of Protection	IP20 (for use only in electric control room or control panel of IP54 or higher protection)
<b>Mechanical Specifications</b>	Weight	450 g approx.
	Connection Method	Screw terminal
	Mounting	DIN rail
	Size	45 x 104.2 x 120 mm
	Standards	UL, CSA, TÜV (EN954-1, DIN V VDE0801/A1, EN61496-1, EN60947-5-1), AS-International Association, CE

### SX5A AS-Interface Safety Communication Terminal (Safety Slave)

<b>Indicator Specifications</b>	LED POWER	AS-Interface power: Green
	LED I1/I2	Input status: Yellow
	LED Fault	Communication error or address 0: Red
<b>Electrical Specifications</b>	Operating Voltage Ue	26.5 to 31.6V (from AS-Interface)
	Operating Current Ie	<70mA (without connecting input devices)
<b>Input</b>	Input Points	Mechanical switch 2 points With cross check Cable length <30m
	Power Supply	From AS-Interface
	Operation Level	10 mA
<b>Program Information</b>	Profile	S-0.B.E
	IO Code	0
	ID Code	B
	ID2 Code	E
<b>Data Bit</b>	D0/D1	Depends on the switch 1 input status ON: dynamic code OFF: 0
	D2/D3	Depends on the switch 2 input status ON: dynamic code OFF: 0
<b>Parameter Bit</b>	P0, P1, P2, P3	Unused
<b>Ambient Temperature</b>	Operating Temperature	-25 to +55°C (no freezing)
	Storage Temperature	-25 to +85°C (no freezing)
<b>Structure Specifications</b>	Degree of Protection	IP67 (EN 60529 compliant) *
	Connection Method	AS-Interface: cable-piercing method
	Applicable Base Module	SX5A-G1FA
	Applicable Wire Diameter	ø7 mm
	Weight	180g
	Installation Method	DIN rail or panel mounting
	Standards	UL/c-UL, TÜV (EN 954-1, EN 60947-5-3, EN 51078, AS-Interface Association, CE)



\* See the instruction manual of AS-Interface safety communication terminal.

## Dimensions

### AS-Interface Safety Monitor

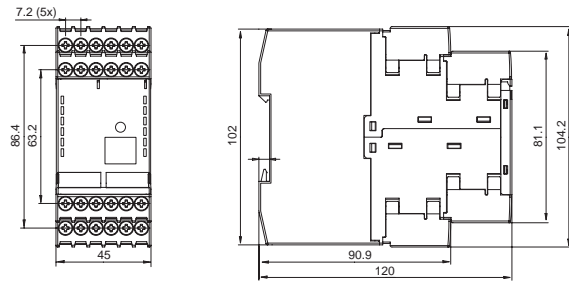

### AS-Interface Safety Communication Terminal

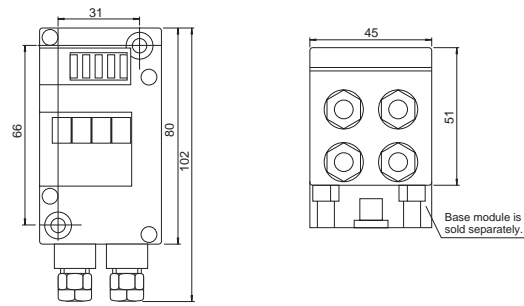

## Wiring

### AS-Interface Safety Monitor Terminal Assignment

Terminal	Description
AS-+	Connection to the AS-Interface bus
AS-	Connection to the AS-Interface bus
L+	+24V DC / supply voltage
M	GND / reference ground
FE	Functional ground
1.Y1	EDM1 / contactor monitoring input (Channel 1)
1.Y2	Start1 / start input (Channel 1)
1.13	Switching output 1 (Channel 1)
1.14	Switching output 2 (Channel 1)
1.23	Switching output 2 (Channel 1)
1.24	Switching output 1 (Channel 1)
1.32	Safety on / message output 1 (Channel 1)
2.Y1	EDM2 / contactor monitoring input (Channel 2)
2.Y2	Start2 / start input (Channel 2)
2.13	Switching output 1 (Channel 2)
2.14	Switching output 2 (Channel 2)
2.23	Switching output 2 (Channel 2)
2.24	Switching output 1 (Channel 2)
2.32	Safety on / message output 2 (Channel 2)

### Wiring Example

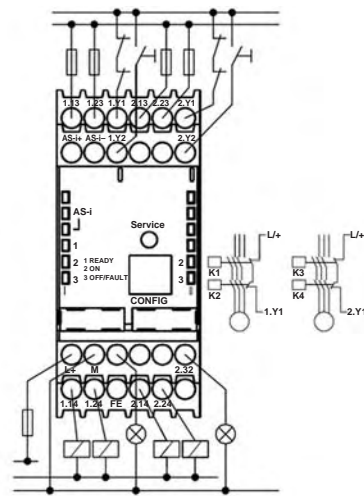

### AS-Interface Safety Communication Terminal Assignment

Terminal	Description
1.1	Mechanical switch 1 +
1.2	Not used
1.3	Mechanical switch 1 -
2.1	Mechanical switch 2 -
2.2	Unused
2.3	Mechanical switch 2 +
3.1	Not used
3.2	Not used
3.3	Not used
4.1	Not used
4.2	Not used
4.3	Not used

### Wiring Example

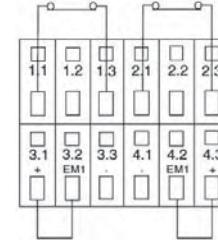

### Block Diagram

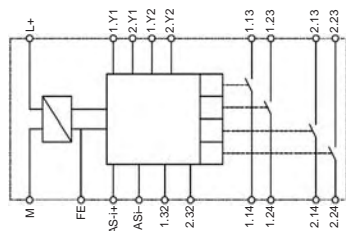

- power supply unit
- control logic
- control for safety switching output 1, channel 1
- control for safety switching output 2, channel 1
- control for safety switching output 1, channel 2
- control for safety switching output 2, channel 2

### Indicators

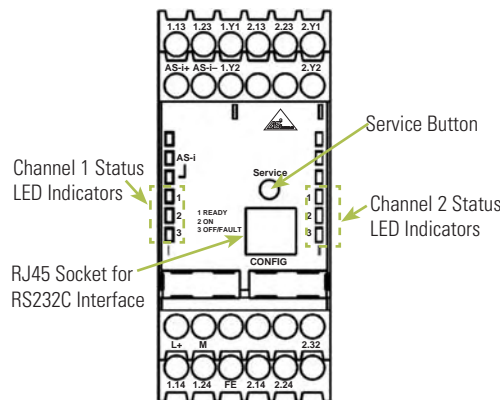

## Emergency Stop Switches

### XA Series/XW Series/FB Series (Plastic Enclosures) with Safety Slave Functions for Direct Connection to the AS-Interface Safety at Work

- Emergency stop switches with safety slave functions can be connected to the AS-Interface Safety at Work network.
- Complies with IEC 61508 SIL3 (Functional safety of electrical/electronic/programmable electronic safety-related systems) and EN954-1 safety category 4 (Safety of machinery-Safety related parts of control systems).
- Space, wire, and labor-saving solutions for safety equipment
- Equipped with AS-Interface standard slave functions. Monitored with AS-Interface master devices.
- A wide variety of safety components:
  - 1) 1-IN (non-illuminated) and 1-IN/1-OUT (illuminated) available.
  - 2) FB series plastic control stations with  $\phi 16\text{mm}$  XA series and  $\phi 22\text{mm}$  XW series emergency stop switches available.
  - 3) XA series available with  $\phi 29\text{mm}$  and  $\phi 40\text{mm}$  mushroom buttons and XW series available with  $\phi 40\text{mm}$  and  $\phi 60\text{mm}$  jumbo mushroom buttons.
  - 4) Terminal connectors are available in insulation displacement, crimping, and M12 connectors which enable effective connection of multiple switches.



### Part Numbers

#### $\phi 16\text{mm}$ XA Series

Button Size	Connector Terminal	I/O Points	Illumination	Part Number	Button/Lens Color
$\phi 29$	IDC	1-IN	Non-illuminated	XA1E-BV3Z10C1R	Red
				XA1E-BV3Z10C1N	Gray
1-IN 1-OUT		Illuminated	XA1E-LV3Z114C1R	Red	
$\phi 40$		1-IN	Non-illuminated		XA1E-BV4Z10C1R
	1-IN 1-OUT		Illuminated	XA1E-LV4Z114C1R	

#### $\phi 22\text{mm}$ XW Series

Button Size	Connector Terminal	I/O Points	Illumination	Part Number	Button/Lens Color
$\phi 40$	IDC	1-IN	Non-illuminated	XW1E-BV4Z10C1R	Red
	Crimping			XW1E-BV4Z10C2R	
	IDC	1-IN 1-OUT	Illuminated	XW1E-LV4Z114C1R	
	Crimping			XW1E-LV4Z114C2R	
$\phi 60$	IDC	1-IN	Non-illuminated	XW1E-BV5Z10C1R	
	Crimping			XW1E-BV5Z10C2R	

#### E-Stop Enclosure

Button Size	Connector Terminal	I/O Points	Illumination	Nameplate	Part Number	Button/Lens Color
$\phi 40$	M12	1-IN	Non-illuminated	Without	FB1W-XW1E-BV4Z10C2R-Y0-1	Red
				With	FB1W-XW1E-BV4Z10C2R-Y1-1	
		1-IN 1-OUT	Illuminated	Without	FB1W-XW1E-LV4Z114C2R-Y0-1	
				With	FB1W-XW1E-LV4Z114C2R-Y1-1	
$\phi 60$	AS- Interface Piercing	1-IN	Non-illuminated	Without	FB1W-XW1E-BV5Z10C2R-Y0-1	
1-IN 1-OUT		Non-illuminated	Without	FB1W-XW1E-BV4Z10C2R-Y0-2		
			With	FB1W-XW1E-BV4Z10C2R-Y1-2		
1-IN 1-OUT		Illuminated	Without	FB1W-XW1E-LV4Z114C2R-Y0-2		
	With		FB1W-XW1E-LV4Z114C2R-Y1-2			
$\phi 60$	AS- Interface Piercing	1-IN	Non-illuminated	Without	FB1W-XW1E-BV5Z10C2R-Y0-2	

1. Units have been evaluated as emergency stop devices by TÜV.  
2. Units with nameplates are engraved "Emergency Stop".

## Accessories

Name	Specification	Part Number
XA/XW Series IDC Connector Kit <sup>1</sup>	End connector (with cover)	XW9Z-C100-1
	Through connector (with cover)	XW9Z-C100-2
IDC Connector Termination Tool	Manufactured by ITW Pancon	MMIT-156F
Crimping Type Connector Cable	Length 500 mm, with one connector	XW9Z-C205
	Length 1m, with one connector	XW9Z-C210
FB Series Control Station M12 Connector Cable	Length 300 mm, straight	FB9Z-CS03
	Length 1m, straight	FB9Z-CS10
	Length 2m, straight	FB9Z-CS20
	Length 1m, right-angle	FB9Z-CL10
	Length 2m, right-angle	FB9Z-CL20
Hand-held Programming Device	<sup>2</sup>	SX9Z-ADR1N

1. Minimum order is 5 pieces. IDC connector termination tool MMIT-156F (ITW Pancon) may be required to connect the cable to the connector.
2. \*Hand-held programming device accessories:  
 -Programming device cable (SX9Z-CN1)  
 -Programming device AC adapter (SX9Z-ADPT)  
 -SwitchNet addressing port adapter (LA9Z-SNADP)

## Specifications

<b>General Specifications</b>	Operating Voltage	26.5 to 31.6V DC (supplied from AS-Interface)		
	Rated Input Current	Illuminated type: 35 mA (XA series), 40 mA (XW, FB series) Non-illuminated type: 25 mA		
	Dielectric Strength	500V AC, 1 minute		
	Insulation Resistance	100 MΩ (500V DC megger)		
	Operating Temperature	XA, XW series: -25 to +55°C (no freezing) FB series: Illuminated type -25 to +50°C (no freezing) Non-illuminated type -25 to +55°C (no freezing)		
	Storage Temperature	-40 to +70°C (no freezing)		
	Operating Humidity	45 to 85% RH (no condensation)		
	Pollution Degree (IEC60664)	XA, XW series - Operator unit: 3, Communication unit: 2, FB series: 3 (2 - per UL)		
	Degree of Protection	Operator unit: IP65		
	IEC60529	Terminal unit: IP20 (FB series: IP65)		
	Corrosion Immunity	Free from corrosive gases		
	Vibration Resistance	Damage limits/Operating extremes: 10 to 500 Hz, amplitude 0.35 mm, acceleration 50 m/s <sup>2</sup>		
	Shock Resistance	Damage limits: 150 m/s <sup>2</sup> , Operating extremes: 1000 m/s <sup>2</sup>		
	Weight (approx.)	XA series ø29: 35g, ø40: 40g XW series ø40: 60g, ø60: 70g FB series M12 connector: 195g (ø40), 205g (ø60) Piercing: 235g (ø40), 245g (ø60)		
<b>Communication Specifications</b>	Communication	AS-Interface Ver. 3.0		
	Slave Type	Safety slave		
	Maximum Network Length	100m total		
	Maximum No. of Slaves	31 (when only safety slaves are connected)		
	Profile (I/O, ID, ID2)	S-7, B, E (illuminated type) S-0, B, E (non-illuminated type)		
	Data Bit	Input	Emergency stop switch D10 D11 D12 D13	
			When pressed 0 0 0 0	
	Data Bit	Output	Emergency stop switch D10 D11 D12 D13	
When not pressed X X X X <small>x:0.1 (unspecified)</small>				
Parameter Bit	D00 = 1 Pilot light: on D01 to 3: not used D00 = 0 Pilot light: off			
Parameter Bit	Not used			

<b>Mechanical/Electrical Specifications</b>	Operating Force	Pushlock: 10.5N (XA series), 32N (XW, FB series) Pull reset: 10N (XA series), 21N (XW, FB series) Turn reset: 0.16N·m (XA series), 0.27 N·m (XW, FB series)
	Minimum Force Required for Direct Opening Action	60N (XA series), 80N (XW, FB series)
	Minimum Operator Stroke Required for Direct Opening Action	4.0 mm
	Maximum Operating Stroke	4.5 mm
	Operating Frequency	900 operations/hour
	Mechanical Life	250,000 operations minimum
	Electrical Life	250,000 operations minimum
	Connectors	IDC connector (XA series) IDC connector, crimping connector (XW series) M12 connector/AS-Interface piercing connector (FB series)
	Recommended Tightening Torque for Locking Ring	0.88 N·m (XA series), 2.0 N·m (XW series)

**Pin Assignment**

**XA/XW Series**

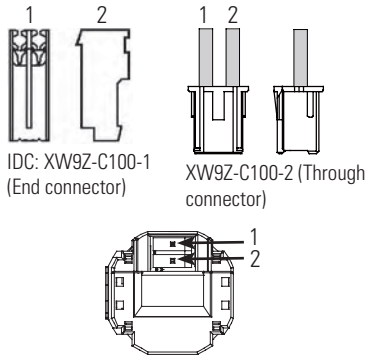

**FB Series**

**(M12 Connector)**

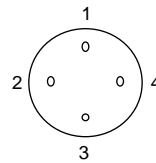

**(AS-Interface Piercing Connector)**

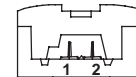

1: AS-i+  
2: AS-i-

## Dimensions

### XA Series

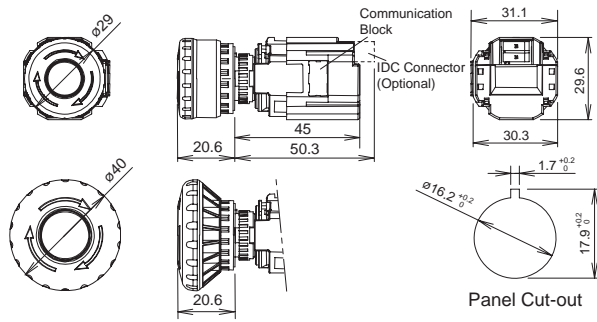

### XW Series

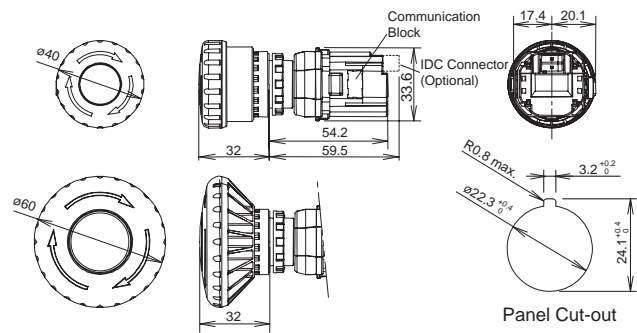

### FB Series

#### AS-Interface Cable Piercing Model

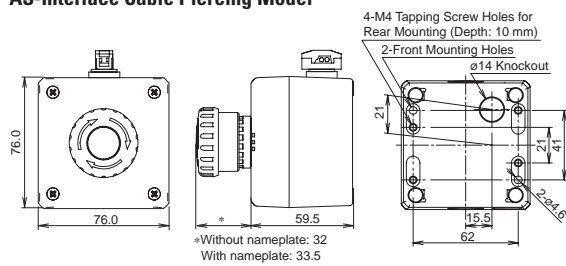

#### M12 Connector Cable for FB Series

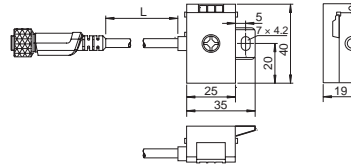

#### M12 Connector Model

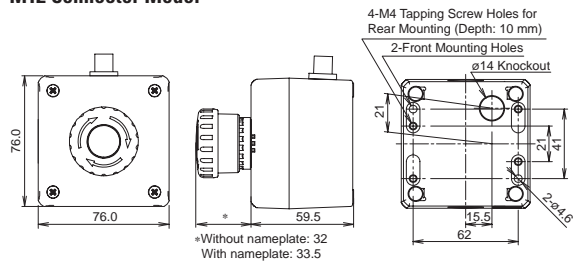

## Mounting Centers

### XA Series

XA Size	X & Y
ø29	40mm minimum
ø40	50mm minimum
ø60	70mm minimum

The above values are for installing with ø16mm pushbutton switches. For using with control units of other size and operator shape, determine the mounting centers in consideration of easy operation and wiring.

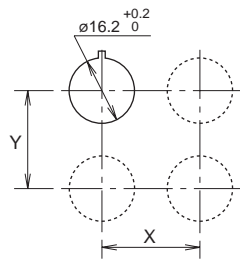

### XW Series

XW Size	øA	X & Y
40mm	22.3 <sup>+0.4</sup>	70mm min

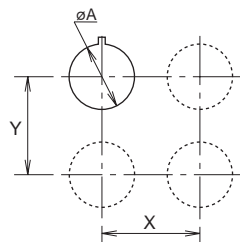

## Resetting

These emergency stop switches are push-lock, pull/turn reset types. When pressed, the operator is latched, and reset by pulling or turning.

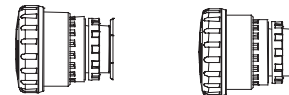

## Operating Instructions

### AS-Interface Safety Monitor

#### Wiring and Installation

Before wiring the interface cable, discharge static electricity. Tighten the screws to a torque of 0.8 to 1.2 N·m.

The AS-Interface power supply unit must separate the main power (input) and output safely according to IEC 60742. It must also maintain a stable supply in the event of instantaneous power failure.

#### Replacing the Safety Slave

Press "Service" button before and after replacing the safety slave. Resetting of safety monitor using the PC is not necessary. After replacement, check whether the new safety slave performs correctly.

#### Replacing the Safety Monitor

The settings of the safety monitor can be transferred to the new safety monitor using the download cable sold separately, and the new safety monitor does not require resetting using software. After replacement, check whether the new safety monitor performs correctly.

### AS-Interface Safety Communication Terminal & Base Module

#### Wiring

The AS-Interface safety communication terminal will be connected to the AS-Interface network via the base module. When only one AS-i flat cable is used, plug the unused grooves using the gaskets supplied with the base module. Tighten the screws to a torque of 0.7 N·m maximum.

Before wiring, disconnect the safety communication terminal and discharge static electricity with an adequate method. Connect the emergency stop switches and interlock switches in normally-closed status.

The slave has two independent inputs for connecting the products to comply with the required safety category. When complying with safety category 4, limit the cable length between the module and the input device to not longer than 30m. For leading in the cables, use the upper part (1 and 2), and tighten the cable gland to a torque of 0.5 to 0.7 N·m.

### Emergency Stop Switches

#### Panel Mounting

The panel thickness should be within the range from 0.8 to 6.0 mm. Remove the locking ring from the operator and check that the rubber gasket is in place. Insert the operator from panel front into the panel hole. Face the side without thread on the operator with TOP marking upward, and tighten the locking ring using ring wrench MW9Z-T1 to a torque of 2.0 N·m maximum. Do not use pliers. Do not tighten with excessive force, otherwise the locking ring will be damaged.

To prevent the XW emergency stop switches from rotating when resetting from the latched position, use of an anti-rotation ring (HW9Z-RL) or a nameplate is recommended.

#### Address Setting

The lid of the address setting device on the side of the unit can be removed by prying it out. Take care not to lose the lid, which comes off completely. By removing the lid of the address setting section, you can see the terminals for connecting a programming cable. Connect the programming cable to the terminals.

To set an address while mounting this product on the panel, more than 60mm space is necessary on the left side in terms of the AS-Interface communication unit. Note that adequate space cannot be allocated by the distance specified with minimum mounting centers. If adequate space cannot be allocated, set the address before installing the product on the panel or set the address after removing the AS-Interface communication unit from the operation section.

#### Wiring

A maximum of 31 units can be connected to a network. Addresses must be assigned to avoid overlaps.

This product allows connecting safety slaves with safety equipment, and normal slaves without safety equipment at the same time. Do not connect safety related signals to a normal slave.

The AS-Interface slaves are divided into two types: A/B slaves with expanded addresses and standard slaves without expanded addresses. If A/B slaves and standard slaves are connected simultaneously, the maximum number of slaves connectable to a network may exceed 31.

The network length is a maximum of 100 meters, including all wires. However, the maximum possible length of the wires may actually be shorter than 100 meters depending on the type of master and composition of slaves. Consider the lengths of cables and wiring topology so that voltage drops in transmission lines are no higher than 3V.

Use applicable two-wire flat cables for wiring.

Do not operate the switch using solid object such as metal or with excessive force, otherwise the switch may be deformed or damaged, causing malfunction or operation failure.