

HE6B 3-position Enabling Switch



Enabling Switch

Five versions—including rectangular mounting hole and ø16mm round mounting hole—are available.



Grip Switch

Light operating force model is available, providing comfortable and stress-free operation for many working hours.



Teach Pendant

Ideal for installation in teach pendants for robots.



HE6B Enabling Switch

3-position enabling switch with monitoring contacts—Smallest in its class ^{Note 1}

- Ergonomically-designed OFF-ON-OFF operation.
- The switch does not turn ON while returning from position 3 (OFF) to position 1 (OFF)
IEC 60204-1 (2005), 10.9
IEC 60947-5-8 (2006), 7.1.9 ^{Note 2}
- Some teach pendants are equipped with two 3-position enabling switches, and when one switch is pressed to position 3 (OFF), the other switch must not enable machine operation even when pressed to position 2. Machine operation can resume after both switches are released. The monitoring switches monitor the OFF status of the 3-position enabling switch, whether the button is returned to position 1 or the button is pressed to position 3 (monitor switches have direct opening action mechanism.)
- Two contacts are provided in a 3-position enabling switch so that even if one contact fails, the other contact will still disable machine operation.
- The waterproof rubber boot provides IP65 protection.



Types

| Type | Contact Configuration/No. of Contacts | | | Color | Part Numbers |
|----------------------|---------------------------------------|----------------------------------|-----------------------------------|--------|--------------|
| | 3-position Switch | Button Return Monitor Switch (↶) | Button Depress Monitor Switch (↷) | | |
| Rubber Boot Included | 2 | 0 | 0 | Yellow | HE6B-M200Y |
| | | | | Black | HE6B-M200B |
| | 2 | 1 | 1 | Yellow | HE6B-M211Y |
| | | | | Black | HE6B-M211B |

- Specify rubber boot color code in place of * in the Type No.

Part Number Guide

HE6B - M 2 0 0 Y

3-position Switch

2: 2 contacts

Monitor Switch

00: No monitor contact

11: 1 contact of button return monitor switch
1 contact of button depress monitor switch

20: 2 contacts of button return monitor switch

02: 2 contacts of button depress monitor switch
(20 and 02 are not standard. Contact IDEC for details.)

Rubber Boot Material, Color

Blank: No rubber boot

Y: Silicon rubber, yellow ^{Note 1}

B: Silicon rubber, black ^{Note 1}

N1: NBR/PVC polyblend, gray ^{Note 2} (Not standard. Contact IDEC)

Notes

1. Silicon rubber: Can be used in general factories. Remains flexible in cold temperatures. Suitable for applications with a wide range of operating temperatures.
2. NBR/PVC polyblend: Oil-proof. Suitable for environments where machine oil may come in contact with the switch, and for painting robots where silicon rubber cannot be used.

Accessories

• Replacement Rubber Boot

| Material, Color | Part Number |
|---|-------------|
| Silicon Rubber Y: yellow B: black | HE9Z-D6① |



- Specify rubber boot color code in place of ① in the part number.

Notes

1. Based on IDEC research as of May 2010
2. IEC 60947-5-8 Control circuit devices and switching elements – Three-position enabling switches

HE6B Enabling Switch

Specifications

| | |
|---|---|
| Applicable Standards | IEC 60947-5-1/EN60947-5-1 IEC 60947-5-8/EN60947-5-8 (TÜV approved) GS-ET-22 (TÜV approved) UL508 (UL recognized) CSA C22.2 No.14 (c-UL recognized) |
| Applicable Standards for Use | ISO 12100/EN ISO 12100, IEC 60204-1/EN 60204-1, ISO 11161/EN ISO 11161, ISO 10218-1/EN ISO 10218-1, ANSI/RIA/ISO 10218-1, ANSI/RIA/R15.06, ANSI B 11.19 ISO 13849-1/EN ISO 13849-1 |
| Operating Temperature | -25 to +60°C (no freezing) |
| Relative Humidity | 45 to 85% RH (no condensation) |
| Storage Temperature | -40 to +80°C (no freezing) |
| Pollution Degree | 2 (inside panel, terminal side) 3 (outside panel, operator side) |
| Contact Resistance | 50mΩ maximum (initial value) |
| Insulation Resistance | Between live and dead metal parts: 100MΩ minimum (500V DC megger) Between terminals of different poles: 10 MΩ minimum (500V DC megger) |
| Impulse Withstand Voltage | 1.5kV (3 position switch) 2.5kV (monitor switch) |
| Operating Frequency | 1200 operations per hour |
| Mechanical Durability | Position 1→2→1: 1,000,000 operations minimum Position 1→2→3→1: 100,000 operations minimum |
| Electrical Durability | 100,000 operations minimum (rated load) 1,000,000 operations minimum (24V AC/DC, 100 mA) |
| Shock Resistance | Operating extremes: 150m/s ² Damage limits: 500m/s ² |
| Vibration Resistance | Operating extremes: 5 to 55 Hz, amplitude 0.5mm Damage limits: 16.7Hz, amplitude 1.5mm |
| Terminal Style | Solder terminal |
| Applicable Wire | 1 cable, 0.5mm ² maximum |
| Solder Terminal Heat Resistance | 310 to 350°C, 3 seconds maximum |
| Terminal Tensile Strength | 20N minimum |
| Locking Ring Recommended Tightening Torque | 0.5 to 0.8N·m |
| Degree of Protection | IP65 (IEC 60529) |
| Conditional Short-circuit Current | 50A (125V): 3-position switch (Use 120V/10A fast acting type fuse for short circuit protection.) (IEC 60127-1) 50A (250V): monitor switch (Use 250V/10A fast acting type fuse for short circuit protection.) (IEC 60127-1) |
| Direct Opening Force | 40N minimum (button release monitor and button depress monitor switches) |
| Direct Opening Stroke (when pressing the entire button surface) | 0.9mm minimum (button return monitor switch) 4.0mm minimum (button depress monitor switch) |
| Operator Strength | 250N minimum (when pressing the entire button surface) |
| Weight (approx.) | 17g |

Dimensions (mm) Mounting Hole Layout

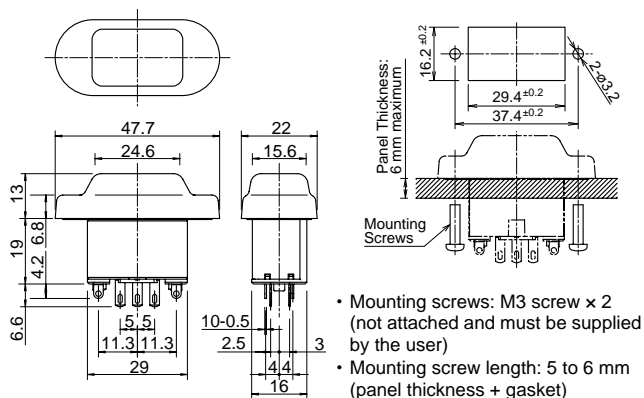

Ratings

| | | | | | | |
|-------------------------------|------------------------------------|----------------|------------------------|------|------|------|
| Rated Insulation Voltage (Ui) | 125V (monitor switch: 250V) | | | | | |
| Rated Thermal Current (Ith) | 3A | | | | | |
| Rated Voltage (Ue) | | 30V | 125V | 250V | | |
| Rated Current (Ie) | 3-position switch | AC | Resistive Load (AC-12) | - | 0.5A | - |
| | | DC | Inductive Load (AC-15) | - | 0.3A | - |
| | Button return monitor switch | AC | Resistive Load (DC-12) | 1A | - | - |
| | | DC | Inductive Load (DC-13) | 0.7A | - | - |
| | Button depress monitor switch (NC) | AC | Resistive Load (AC-12) | - | 2A | 1A |
| | | DC | Inductive Load (AC-15) | - | 1A | 0.5A |
| Contact Configuration | 3-position switch | 2 contacts | | | | |
| | Button return monitor switch | 0 or 1 contact | | | | |
| Contact Configuration | Button depress monitor switch | 0 or 1 contact | | | | |

- Minimum applicable load (reference value): 3V AC/DC, 5mA (Applicable operation area depends on the operating conditions and load.)

TÜV ratings:

3 position switch:
 AC-12 125V/0.5A
 DC-12 30V/1A
 DC-13 30V/0.7A
 Monitor Switch:
 AC-15 250V/0.5A
 DC-13 125V/0.22A
 DC-13 30V/1A

UL ratings:

3-position switch:
 125V AC/0.5A (Resistive)
 30V DC/1A (Resistive)
 Monitor switch:
 250V AC/0.5A (General use)
 30V DC/1A (General use)

Operating Characteristics

• HE6B-M211

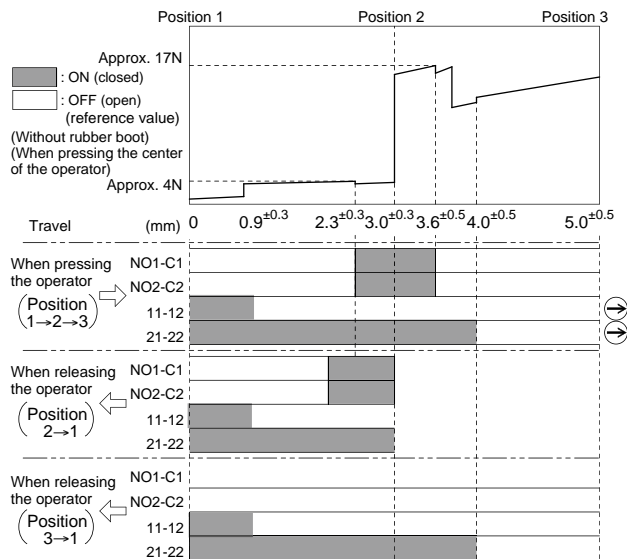

Notes:

- When a rubber boot is used, the operating force depends on the operating temperature.
- The operating force to move the button from position 2 to position 3 can be changed. For details, contact IDEC.

Terminal Arrangement (bottom view)

• HE6B-M211

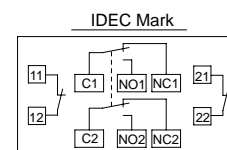

- 3-position switch 2 contacts ^{Note 1}
- Button return monitor switch: 1 contact, terminals 11-12
- Button depress monitor switch: 1 contact, terminals 21-22
- There are no terminals 11-22 and 21-22 for HE6B-M200 type.

Note 1: Use NO and C terminals for OFF→ON→OFF 3-position switch (NC terminal is not used.)

Safety Precautions

- The HE6B enabling switch has been designed for industrial applications. Use of the HE6B enabling switch for residential, commercial, or lighting applications may cause unwanted electromagnetic disturbances and the user may be required to take adequate mitigation measures.
- In order to avoid electric shock or fire, turn the power off before installation, removal, wiring, maintenance, or inspection of the enabling switch.
- Provide mounting panel with sufficient support. Insufficient mounting panel strength or excessive operating force may damage the enabling switch, resulting in electric shock or fire.
- Use wires of the proper size to meet voltage and current requirements, and solder the wires correctly according to the wiring instruction described below. If soldering is incomplete, the wire may heat during operation, causing a fire hazard.
- When using the enabling switch in a safety related part of a control system, use the enabling switch properly in accordance with the safety standards and regulations of the actual machine, system, and application, of the country or region where the enabling switch is used. Also, perform a risk assessment before using the enabling switch.
- Do not disable the safety function of the enabling switch by using tape, elastic band, or by disfiguring the rubber boot, otherwise the loss of enabling switch function may cause serious accidents.

Instructions

Operating Instructions

- 3-position enabling switches on teach pendants are used to enable machine operation in a hazardous area only when pressed to position 2 (pressed for 3 mm). Systems must be designed to enable machine operation when the enabling switch is in position 2 only.
- In order to ensure a high level of system safety, connect the two contacts of the 3 position enabling switch to a disagreement detection circuit (e.g. safety relay module). (ISO 13849-1/EN954-1)
- Because the two contacts are designed to operate independently, pressing the edge of a button turns on one contact earlier than the other contact, causing a delay in operation. To avoid this, always press the center of the button.
- Perform a risk assessment in actual applications as strong force may be applied to a 3-position enabling switch when depressed to position 3.
- Perform a risk assessment for the shape and structure of the mounting area, where the enabling switch is installed, to prevent unintended operation of the enabling switch. For example, an enabling switch protruding from the teach pendant may result in unintended operation of the enabling switch.
- Because strong force may be applied to a 3-position enabling switch when depressed to position 3, provide sufficient strength to the area where the 3-position enabling switch will be mounted.

Installation

- The ridge on the bottom of rubber boot serves as a seal, and waterproof characteristics are attained when the ridge is tightly installed in a mounting panel. When the mounting panel is bent and the ridge cannot be pressed flush to the panel, add a reinforcing rib to secure the boot to the mounting panel.
- If the surface of mounting panel is uneven, waterproof characteristics of the enabling switch with rubber boot cannot be

achieved. In addition, make sure that the mounting panel has sufficient strength to properly mount the enabling switch.

- The edge of rubber boot may stick out if excessive force is applied. When such an event is anticipated, it is recommended to embed the rubber boot in the mounting panel as shown in the figure below.

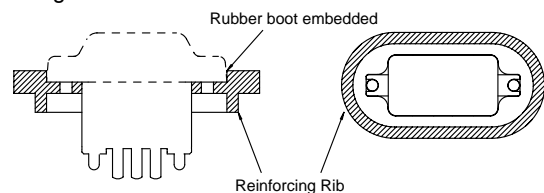

- When an enabling switch with a rubber boot is mounted in a hermetically-sealed control box, a large change in internal air pressure may cause the rubber boot to inflate and deflate, affecting the performance of the enabling switch. Check periodically to make sure that the enabling switch is operating correctly.

Wiring Instructions

- Applicable wire size: 0.5 mm² maximum × 1 pc.
- Solder the terminal at a temperature of 310 to 350°C maximum within 3 seconds using a soldering iron. Do not use flow or dip soldering. Sn-Ag-Cu type is recommended when using lead-free solder.
- When soldering, do not touch the enabling switch with the soldering iron. Also ensure that no tensile force is applied to the terminals. Do not bend or apply excessive force to the terminals.
- Use non-corrosive liquid rosin as soldering flux.

