

PS3X Series Switching Power Supplies

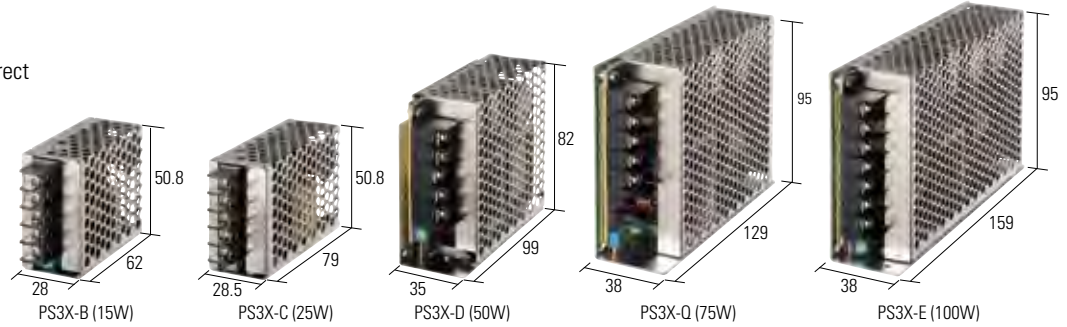

Features

- Compact size
- Universal AC input voltage
- 5V, 12V, and 24V DC outputs
- Available with mounting brackets for direct or DIN rail mounting
- Overcurrent/overvoltage protection
- EMC, EN55022 Class B compliant
- UL/c-UL recognized, TUV



Part Numbers

Power Supply

Appearance	Output Capacity	Part Number	Input Voltage	Output Voltage	Output Current
	15W	PS3X-B05AFC	100 to 240V AC	5V	3.0A
		PS3X-B12AFC		12V	1.3A
		PS3X-B24AFC		24V	0.63A
	25W	PS3X-C05AFC		5V	5.0A
		PS3X-C12AFC		12V	2.1A
		PS3X-C24AFC		24V	1.1A
	50W	PS3X-D12AFG		12V	4.2A
		PS3X-D24AFG		24V	2.2A
	75W	PS3X-Q05AFG		5V	12.0A
		PS3X-Q12AFG		12V	6.0A
		PS3X-Q24AFG		24V	3.2A
	100W	PS3X-E05AFG		5V	16.0A
		PS3X-E12AFG		12V	8.5A
		PS3X-E24AFG		24V	4.5A

L-shaped Mounting Bracket (optional)

Applicable Power Supply	Part Number
PS3X-B	PS9Z-3N3A
PS3X-C	PS9Z-3N3B
PS3X-D	PS9Z-3E3B
PS3X-Q	PS9Z-3N3E
PS3X-E	

DIN-rail Mounting Bracket (optional)

Applicable Power Supply	Part Number
PS3X-B	PS9Z-3N4B
PS3X-C	
PS3X-D	PS9Z-3E4C
PS3X-Q	PS9Z-3E4D
PS3X-E	

DIN Rail

Appearance	Part Number	Length	Material	Weight (g)
	BNDN1000	1000mm	Aluminum	200

End Clips

Appearance	Part Number	Description
	BNL5	small DIN rail end clip
	BNL6	medium DIN rail end clip (the BNL6 has a higher profile than BNL5)

Part Number Configuration

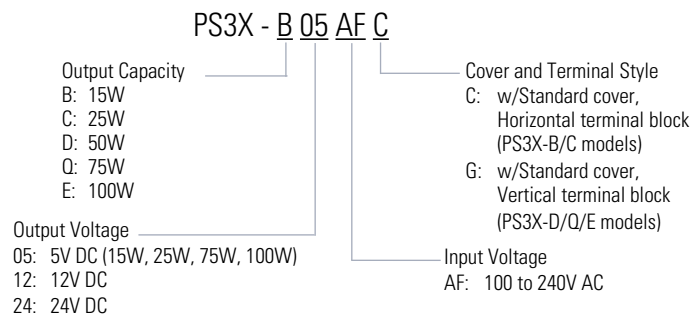

Specifications

Description		Power Supplies	[15W] PS3X-B05/B12/B24	[25W] PS3X-C05/C12/C24	[50W] PS3X-D12/D24	[75W] PS3X-Q05/Q12/Q24	[100W] PS3X-E05/E12/E24	
Input	Rated Input Voltage		100 to 240V AC					
	Voltage Range (Note 1)		85 to 264V AC/ 120 to 375V DC	88 to 264V AC / 125 to 375V DC				
	Frequency		47 to 63 Hz					
	Input Current		0.5A max.	0.65A max.	1.3A max.	1.8A max.	2.5A max.	
	Inrush Current (Ta = -25°C, ACV cold start)	at 115V AC		40A max.	30A max.	30A max.	30A max.	35A max.
		at 230V AC		60A max.	50A max.	50A max.	50A max.	70A max.
	Leakage Current		0.5mA max.	1.5mA max.	1.5mA max.	1.5mA max.	1.5mA max.	
Efficiency (Typ.) (230V AC at input/rated output)	5V		77%	77%	—	77%	77%	
	12V		81%	81%	81%	82%	81%	
	24V		82%	84%	84%	84%	84%	
Output	Rated Voltage/Current		5V, 3A	5V, 5A	—	5V, 12A	5V, 16A	
			12V, 1.3A	12V, 2.1A	12V, 4.2A	12V, 6A	12V, 8.5A	
			24V, 0.63A	24V, 1.1A	24V, 2.2A	24V, 3.2A	24V, 4.5A	
	Adjustable Voltage Range		±10%					
	Output Holding Time		13 ms typ. (100V AC) 60 ms minimum (230V AC)	10 ms typ. (100V AC) 60 ms minimum (230V AC)	23 ms typ. (100V AC) 60 ms minimum (230V AC)	14 ms typ. (100V AC) 60 ms minimum (230V AC)	17 ms typ. (100V AC) 80 ms minimum (230V AC)	
	Start Time		1000 ms max. (230V AC input, rated output)					
Rise Time			50 ms max. (230V AC input, rated output)	30 ms max. (230V AC input, rated output)	30 ms max. (230V AC input, rated output)	30 ms max. (230V AC input, rated output)	30 ms max. (230V AC input, rated output)	
	Regulation	Input Fluctuation	0.5% max.					
		Overvoltage Fluctuation	5V: ±2% max. 12V, 24V: ±1% max.					
Ripple (including noise)	Temperature Fluctuation	0.04% / °C max. (-20 to +50°C)						
	-20 to -10°C		5V: 200mV max. 12V/24V: 200mV max.	5V: 140mV max. 12V: 240mV max. 24V: 300mV max.	—	—	—	
		-10 to 0°C		5V: 160mV max. 12V/24V: 200mV max.	5V: 140mV max. 12V: 240mV max. 24V: 300mV max.	12V: 240mV max. 24V: 300mV max.	5V: 140mV max. 12V: 240mV max. 24V: 300mV max.	5V: 160mV max. 12V: 240mV max. 24V: 300mV max.
	PS3X-B, C: 0 to +50°C PS3X-D, Q, E: 0 to +45°C		5V: 100mV max. 12V/24V: 150mV max.	5V: 70mV max. 12V: 120mV max. 24V: 150mV max.	12V: 120mV max. 24V: 150mV max.	5V: 70mV max. 12V: 120mV max. 24V: 150mV max.	5V: 100mV max. 12V: 120mV max. 24V: 150mV max.	
Supplementary Functions	Overcurrent Protection		105% min. (auto reset) (Note 2)					
	Overvoltage Protection		Voltage limitation at 115% min.		Intermittent operation or output off at 115% min. (Note 3)			
	Operation Indicator		green LED					
Dielectric Strength	Between input and output terminals		3000V AC, 1 minute					
	Between input and ground terminals		2000V AC, 1 minute					
	Between output and ground terminals		500V DC, 1 minute					
Insulation Resistance		100MΩ minimum, 500V DC megger (between input and output terminals, between input and ground terminals)						
Operating Temperature		-20 to +70°C (no freezing, see output derating)			-10 to +70°C (no freezing, see output derating)			
Operating Humidity		20 to 85% RH (no condensation)						
Storage Temperature		-40 to +85°C (no freezing)						
Storage Humidity		10 to 95% RH (no condensation)						
Vibration Resistance		10 to 55 Hz, 20m/s ² constant, 2 hours each in 3 axes						
Shock Resistance		200m/s ² , 1 shock each in 3 axes						
EMC	EMI		EN55022 Class B					
	EMS		EN55024					
Safety Standards		IEC/EN60950-1, UL60950-1, CSA C22.2 No. 60950-1						
Dimensions (H × W × D) (mm)		50.8H × 28W × 62D	50.8H × 28.5W × 79D	82H × 35W × 99D	95H × 38W × 129D	95H × 38W × 159D		
Weight (approx.)		130g	180g	340g	500g	700g		
Terminal Screw		M3			M3.5			

Note 1: See "Output Current vs. Input Voltage" characteristics next page. Not subject to safety standards. When using DC input, connect a fuse to the input terminal for DC input protection.

Note 2: Overload for 30 seconds or longer may damage the internal elements.

Note 3: One minute after the output has been turned off, turn on the AC input again.

Characteristics

Operating Temperature vs. Output Current (Derating Curves)

Conditions: Natural air cooling (operating temperature is the temperature around the power supply)

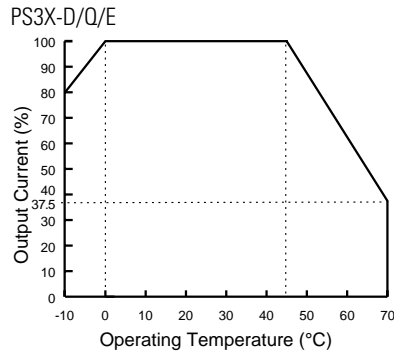
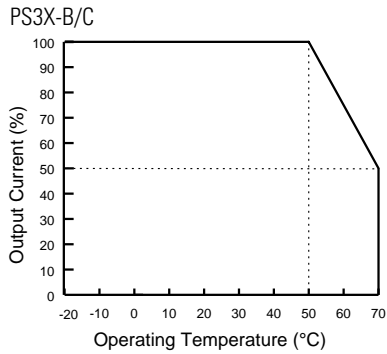

Overcurrent Protection Characteristics

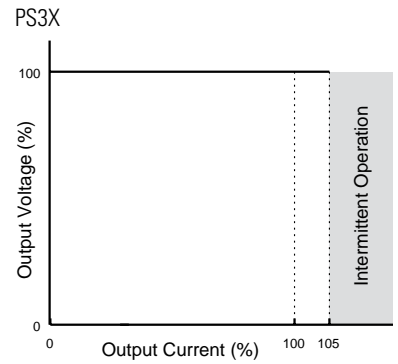

Output Current vs. Input Voltage (TA = 25°C)

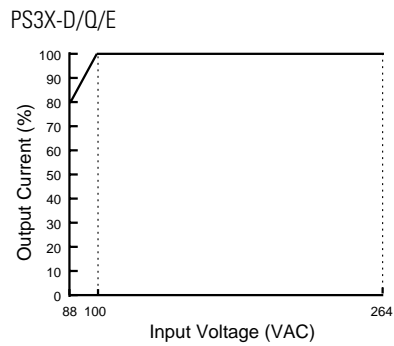
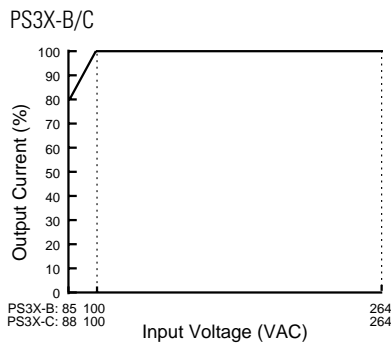

Operating Temperature by Safety Standards

Power Supplies	UL/EN60950-1
	Mounting A, B
PS3X-B05, -B12, -B24 PS3X-C05, -C12, -C24	50°C
PS3X-D12, -D24 PS3X-Q05, -Q12, -Q24 PS3X-E05, -E12, -E24	45°C

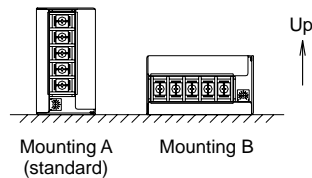

Note: Observe the derating curves when operating PS3X power supplies.

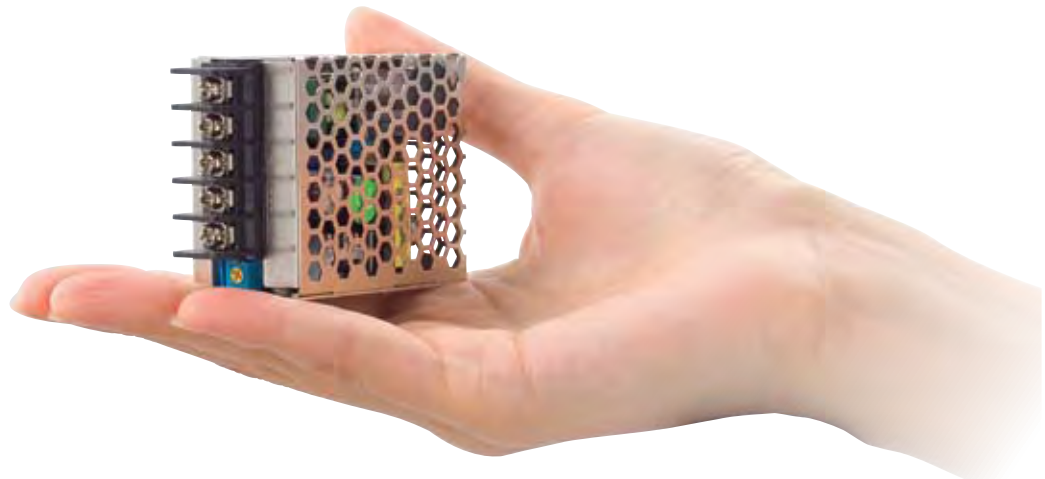

Dimensions (mm)

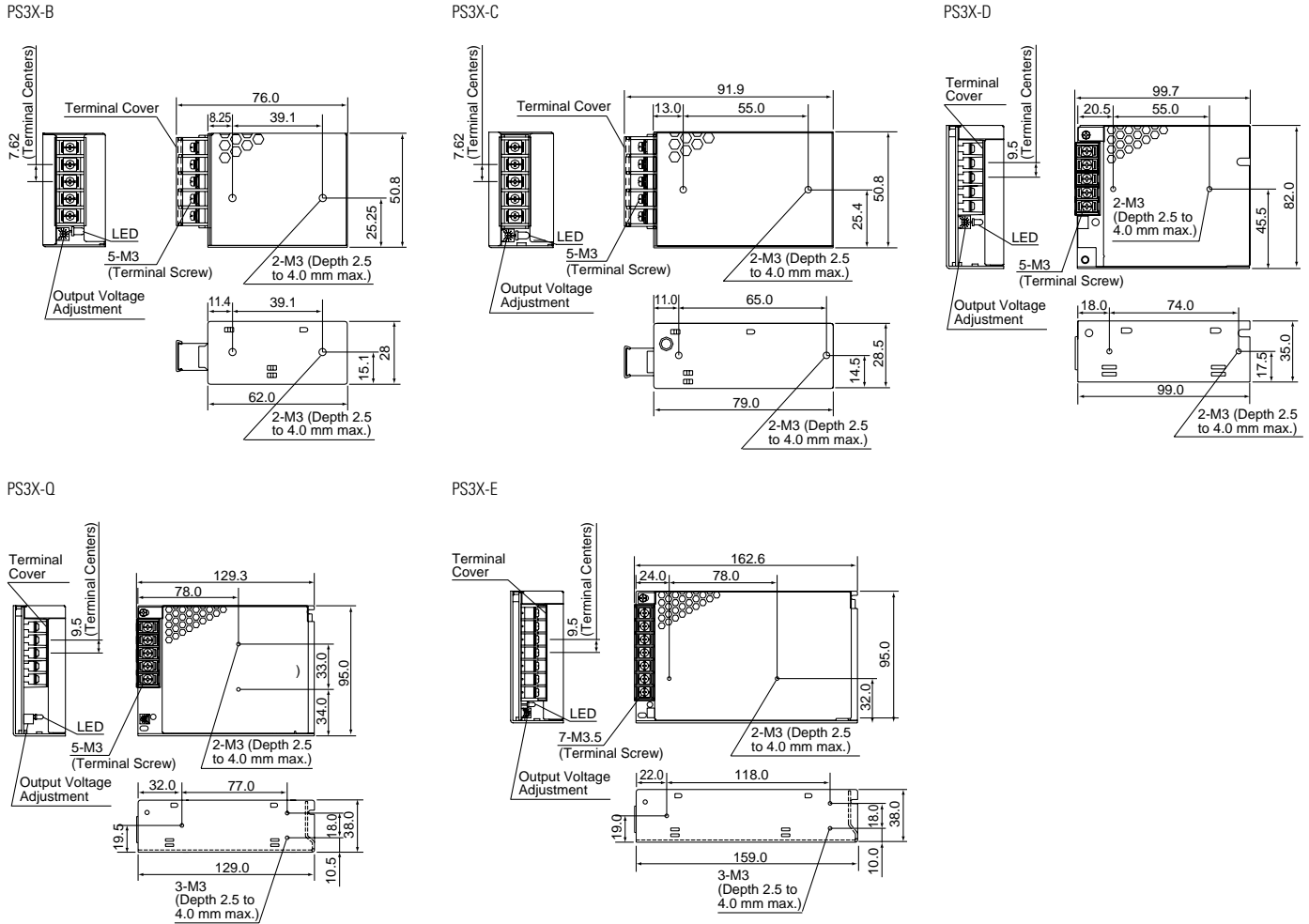

Terminal Markings

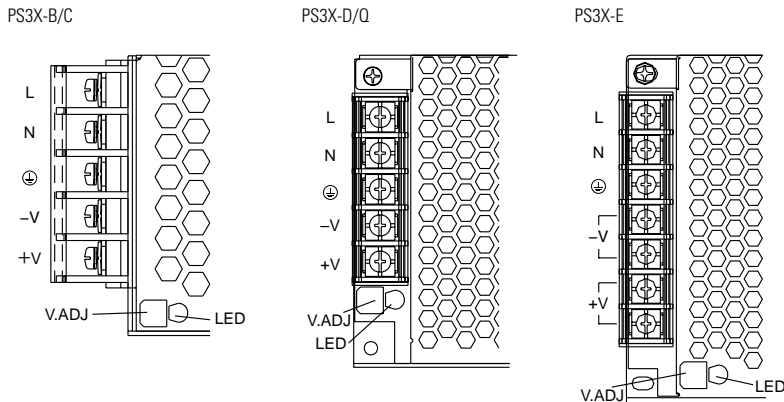

Marking	Name	Description
L, N	AC Input Terminal	Accepts a wide range of voltage and frequency. Polarity does not matter when using DC input.
⊕	Ground Terminal	Be sure to connect this terminal to a proper ground.
+V, -V	DC Output Terminals	Positive and negative output terminals
V.ADJ	Output Voltage Adjustment	Allows adjustment within ±10%. Turning clockwise increases the output voltage.
LED	Power status	Illuminates (green) when input power is applied.

L-shaped Mounting Bracket

PS9Z-3N3A (for 15W)

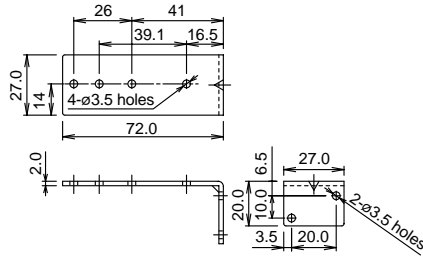

PS9Z-3N3B (for 25W)

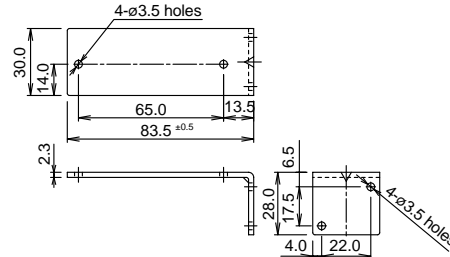

PS9Z-3E3B (for 50W)

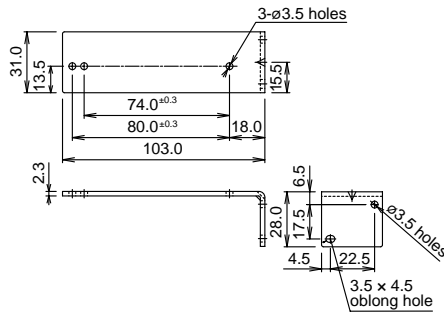

PS9Z-3N3E (for 75W/100W)

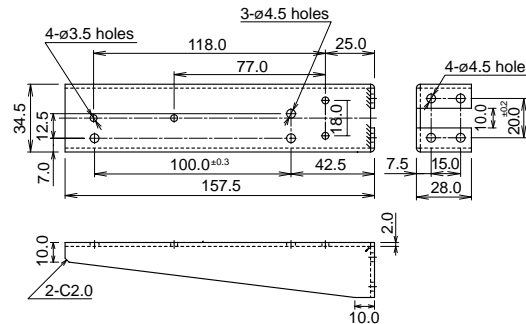

DIN-rail Mounting Bracket

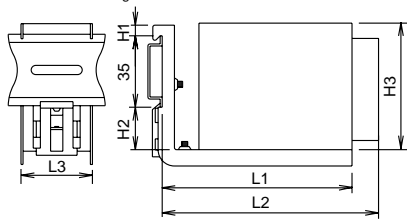

Part Number	Applicable Power Supply	L1	L2	L3	H1	H2	H3
PS9Z-3N4B	PS3X-B	95	105.5	35	5.2	20.5	50.8
	PS3X-C	95	113	35	5.2	20.5	50.8
PS9Z-3E4C	PS3X-D	136	117*	35	5.2	20.5	82
PS9Z-3E4D	PS3X-Q	188	141*	39.5	5.2	19.7	95
	PS3X-E	188	173*	39.5	5.2	19.7	95

* Note that L2 is shorter than L1.

Instructions

Installation Notes

- When mounting the PS3X switching power supply, see the figure on the right.
- See dimension drawings for mounting hole layouts.
- Use M3 screws for mounting. Choose screws that protrude 2.5 to 4mm from the surface of the switching power supply.
- Do not cover the openings of the switching power supply. Ensure proper heat dissipation by convection.
- Maintain a minimum of 20mm clearance around the power supply.
- When derating of the output does not work, provide forced air-cooling.
- Make sure to wire the ground terminal correctly.
- For wiring, use wires with heat resistance of 60°C or higher. Use copper wire.
- Recommended tightening torque of terminal screws: 0.8 N-m

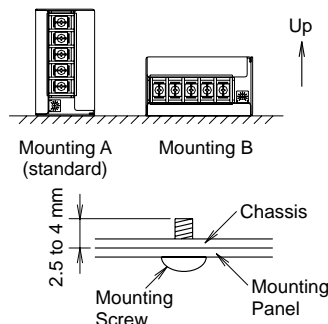

Overcurrent Protection

The output voltage drops automatically when an overcurrent flows, resulting in intermittent operation. Normal voltage is automatically restored when the load returns to normal conditions. However, overcurrent for a prolonged period of time or short-circuit causes the internal elements to deteriorate or break down.

Overvoltage Protection

PS3X-B/C: Voltage limit and auto-recovery method. The switching power supplies operate normally when voltage returns to normal.
PS3X-D/Q/E: The output is turned off when an overvoltage is applied. When the output voltage has dropped due to an overvoltage, turn the input off, and after one minute, turn the input on again.

Series Operation

When connecting two switching power supplies in a series, insert a Schottky diode to each output.

Parallel Operation

Parallel operation is not possible.

Insulation/Dielectric Test

When performing an insulation/dielectric test, short the input (between AC and output (between + and -). Do not apply or interrupt the voltage suddenly, otherwise surge voltage may be generated and the power supply may be damaged.

Adjustment of Output Voltage

The output voltage can be adjusted within $\pm 10\%$ of the rated output voltage by using the V.ADJ control. Turning the V.ADJ clockwise increases the output voltage. Turning counterclockwise decreases the output voltage. Note that overvoltage protection may work when increasing the output voltage.

Safety Precautions

- Do not use switching power supplies with equipment where failure or inadvertent operation may harm anyone, such as medical, aerospace, railway, nuclear, etc. PS3X switching power supplies are designed for use in general electric equipment such as office, communication, measuring, and industrial electric devices.
- Do not disassemble, repair, or modify the power supplies, otherwise electric shock, fire, or failure may occur.
- Do not install the switching power supply in places where someone will touch it when input voltage is applied. Do not touch the switching power supply while input voltage is applied and right after the power is turned off, because high temperature and high voltage may cause burns and electric shocks.
- Do not short circuit the output terminals or output lead wires, otherwise fire or damage may occur.
- Provide the final product with protection against failure or damage that may be caused by malfunction of the switching power supply. Damaged switching power supply may cause overvoltage on the output terminals, or may cause voltage drop.
- Turn off power before wiring. Also, make sure to wire correctly. Improper wiring may cause electric fire or damage.
- Do not use switching power supplies to charge rechargeable batteries.
- Make sure that the input voltage does not exceed the rating. Note polarity of input and output terminals and wire correctly. Incorrect wiring may cause blown fuses (AC input power), smoke or fire.
- Do not touch the inside of the switching power supply, and make sure that foreign objects do not enter the switching power supply, otherwise an accident or failure may occur.
- Observe the temperature derating curves. Operating temperature refers to the temperature around the lower part of the switching power supply. Failure to observe the derating curves could result in an internal temperature rise and possible failure of the switching power supply.
- The fuse inside the switching power supply is for AC input. When using with DC input, install an external fuse.
- Do not set the V. ADJ control over the setting range, otherwise performance deterioration or failure may occur.
- When failure or error occurs, shut down the input to the switching power supply, and contact IDEC.
- Do not use or store the switching power supply in a place subject to extreme vibration or shocks, otherwise failure will result.
- Do not use the switching power supply where it is subject to or near:
 - Direct sunlight, heat or high temperatures
 - Metal powder, oil, chemicals or hydrogen sulfide
 - Highly humid areas, such as a basement or conservatory
 - Inside freezers or refrigerators, near cooler exhaust, or other cold environments

PS5R Slim Line Power Supplies

- Lightweight and compact in size
- Wide power range: 10W-240W
- Universal input:
 - 10W to 90W: 85-264V AC/100-370V DC
 - 120W and 240W: 85-264V AC/100-350V DC
- Power Factor Correction for 60W to 240W (EN61000-3-2)
- Meets SEMI F47 Sag Immunity (120W & 240W only)
- Approved for Class 1, Div. 2 Hazardous Locations
- Overcurrent protection, auto-reset
- Overvoltage protection, shut down
- Spring-up screw terminal type, IP20
- DIN rail or panel surface mount
- Approvals:
 - CE Marked
 - TÜV
 - c-UL, UL508
 - UL1310 (PS5R-SB, -SC, -SD)
 - UL/ANSI 12.12.01-2007 (Hazardous locations)
 - EN50178:1997
 - LVD: EN60950:2000
 - EMC: Directive EN61204-3:2000 (EMI: Class B, EMS: Industrial)



PS5R Slim Line models give you all the power of a traditional power supply in only half the space. The 10W and 15W are only 22.5mm wide, the 30W and 60W are 36mm wide, and the 90W is 46mm wide. The 120W unit has a width of only 50mm while the 240W is 80mm wide. They also come with all the convenient features you've come to expect from IDEC.

Utilize them in tight spaces or save valuable DIN Rail space while still filling your requirements for power. With all the available choices, it's easy to find the one that's right for your application!

