

## 16mm XA E-Stops

### Key features:

- Lead-free, RoHS compliant, (EU directive 2002/95/EC)
- The depth behind the panel is only 27.9mm for 1 to 4 contacts, illuminated and non-illuminated types.
- IDEC's original "Safe break action" ensures that the NC contacts open when the contact block is detached from the operator.
- 1 to 4NC main contacts and 1NO monitor contact
- Push-to-lock, Pull or Turn-to-reset operator
- Direct opening action mechanism (IEC60947-5-5, 5.2, IEC60947-5-1, Annex K)
- Safety lock mechanism (IEC60947-5-5, 6.2)
- Degree of protection IP65 (IEC60529)
- Two button sizes:  $\varnothing 29$  and  $\varnothing 40$ mm
- UL, c-UL recognized. EN compliant
- UL NISD2 category emergency stop button (File #E305148)



CCC No. 2005010305150899

### Specifications

<b>Applicable Standards</b>	IEC60947-5-1, EN60947-5-1, IEC60947-5-5, EN60947-5-5 UL508, CSA C22.2 No. 14
<b>Operating Temperature</b>	Non-illuminated: -25 to +60°C (no freezing), Illuminated: -25 to +55°C (no freezing)
<b>Operating Humidity</b>	45 to 85% RH (no condensation)
<b>Storage Temperature</b>	-45 to +80°C
<b>Operating Force</b>	Push-to-lock: 10.5N Pull-to-reset: 10N Turn-to-reset: 0.16N·m
<b>Minimum Force Required for Direct Opening Action</b>	60N
<b>Min Operator Stroke Required for Direct Opening Action</b>	4mm
<b>Maximum Operator Stroke</b>	4.5mm
<b>Contact Resistance</b>	50m $\Omega$ maximum (initial value)
<b>Contact Material</b>	Gold plated silver
<b>Insulation Resistance</b>	100M $\Omega$ minimum (500V DC megger)
<b>Impulse Withstand Voltage</b>	2.5kV
<b>Pollution Degree</b>	3 (inside LED unit: 2)
<b>Operation Frequency</b>	900 operations/hour
<b>Shock Resistance</b>	Operating extremes: 150m/s <sup>2</sup> (15G), Damage limits: 1000m/s <sup>2</sup> (100G)
<b>Vibration Resistance</b>	Operating extremes: 10 to 500Hz, amplitude 0.35mm acceleration 50m/s <sup>2</sup> Damage limits: 10 to 500Hz, amplitude 0.35mm acceleration 50m/s <sup>2</sup>
<b>Mechanical Life</b>	250,000 operations minimum
<b>Electrical Life</b>	100,000 operations minimum, (250,000 operations minimum @ 24V AC/DC, 100mA)
<b>Degree of Protection</b>	IP65 (IEC60529)
<b>Terminal Style</b>	Solder terminal, PC board terminal
<b>Recommended Tightening Torque for Locking Ring</b>	0.88N·m
<b>Wire Size</b>	16 AWG max
<b>Soldering Conditions</b>	310 to 350°C, 3 seconds maximum
<b>Weight</b>	$\varnothing 29$ mm: 23g $\varnothing 40$ mm: 28g

Part Numbers

Non-Illuminated XA E-Stop

Operator	Termination	Monitor Contacts	Main Contacts	Part Number
 29mm Mushroom	PCB Terminal	1NO	1NC	XA1E-BV311V-R
		-	2NC	XA1E-BV302V-R
		1NO	3NC	XA1E-BV313V-R
		-	4NC	XA1E-BV304V-R
	Solder Terminal	1NO	1NC	XA1E-BV311-R
		-	2NC	XA1E-BV302-R
		1NO	3NC	XA1E-BV313-R
		-	4NC	XA1E-BV304-R
 40mm Mushroom	PCB Terminal	1NO	1NC	XA1E-BV411V-R
		-	2NC	XA1E-BV402V-R
		1NO	3NC	XA1E-BV413V-R
		-	4NC	XA1E-BV404V-R
	Solder Terminal	1NO	1NC	XA1E-BV411-R
		-	2NC	XA1E-BV402-R
		1NO	3NC	XA1E-BV413-R
		-	4NC	XA1E-BV404-R

Illuminated XA E-Stop

Operator	Termination	Monitor Contacts	Main Contacts	Part Number
 29mm Mushroom	PCB Terminal	1NO	1NC	XA1E-LV311Q4V-R
		-	2NC	XA1E-LV302Q4V-R
		1NO	3NC	XA1E-LV313Q4V-R
		-	4NC	XA1E-LV304Q4V-R
	Solder Terminal	1NO	1NC	XA1E-LV311Q4-R
		-	2NC	XA1E-LV302Q4-R
		1NO	3NC	XA1E-LV313Q4-R
		-	4NC	XA1E-LV304Q4-R
 40mm Mushroom	PCB Terminal	1NO	1NC	XA1E-LV411Q4V-R
		-	2NC	XA1E-LV402Q4V-R
		1NO	3NC	XA1E-LV413Q4V-R
		-	4NC	XA1E-LV404Q4V-R
	Solder Terminal	1NO	1NC	XA1E-LV411Q4-R
		-	2NC	XA1E-LV402Q4-R
		1NO	3NC	XA1E-LV413Q4-R
		-	4NC	XA1E-LV404Q4-R



All illuminated XA E-Stops come with a replaceable 24V AC/DC LED.

Overview

X Series E-Stops

Door Interlock Switches

Enabling Switches

Barriers

AS-Interface Safety at Work

**Contact Ratings**

<b>Rated Insulation Voltage (Ui)</b>		300V (illuminated part: 60V)				
<b>Current (Ith)</b>		5A				
<b>Rated Operating Voltage (Ue)</b>		30V	125V	250V		
<b>Rated Operating Current</b>	<b>Main Contacts (NC)</b>	AC 50/60Hz	Resistive Load (AC-12)	–	3A	3A
			Inductive Load (AC-15)	–	1.5A	1.5A
	DC	Resistive Load (DC-12)	2A	0.4A	0.2A	
		Inductive Load (DC-13)	1A	0.22A	0.1A	
<b>Rated Operating Current</b>	<b>Monitor Contacts (NO)</b>	AC 50/60Hz	Resistive Load (AC-12)	–	1.2A	0.6A
			Inductive Load (AC-14)	–	0.6A	0.3A
	DC	Resistive Load (DC-12)	2A	0.4A	0.2A	
		Inductive Load (DC-13)	1A	0.22A	0.1A	

Minimum applicable load: 5V AC/DC, 1mA (reference value).  
The rated operating currents are measured at resistive/inductive load types specified in IEC 60947-5-1.

**Illuminated Unit LED Ratings**

Operating Voltage	Current
24V AC/DC ±10%	11mA

**Depth Behind the Panel**

Depth (mm)	Description
27.9	1 - 4 contacts, both illuminated and non-illuminated

**Mounting Hole Layout**

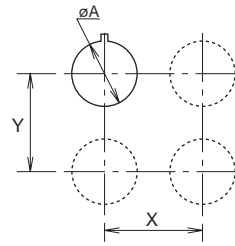

Measurements

Model	øA	X & Y
ø29mm	16.2 <sup>+0.2</sup>	40mm min
ø40mm		50mm min

**Panel Cutout**

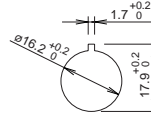

**PC Board Layout - Bottom View**

Non-Illuminated

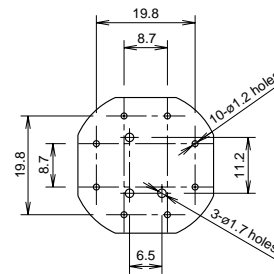

Illuminated

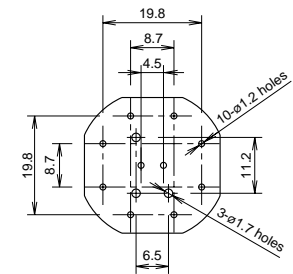

**Part Number Key**

**XA1E - L V 3 11 Q4 V - R**

**Illumination**

B: Non-Illuminated  
L: Illuminated

**Contact Configuration**

11: 1NO - 1NC  
02: 2NC  
13: 1NO - 3NC  
04: 4NC

**Terminal**

Blank: solder tab  
V: PCB

**Mushroom Size**

3: ø29mm  
4: ø40mm

**Voltage Code**

Blank: Non-illuminated  
Q4: Illuminated 24V AC/DC

**Terminal Arrangements (Bottom View)**

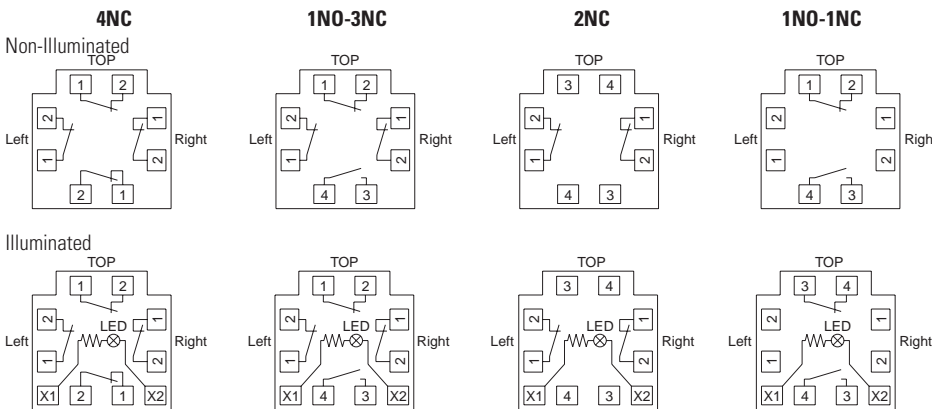

Dimensions (mm)

Overview

X Series E-Stops

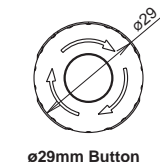

ø29mm Button

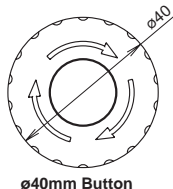

ø40mm Button

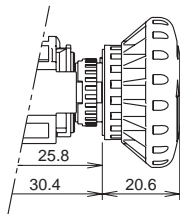

Non-Illuminated

Mounting Panel Thickness: 0.5 to 3.7

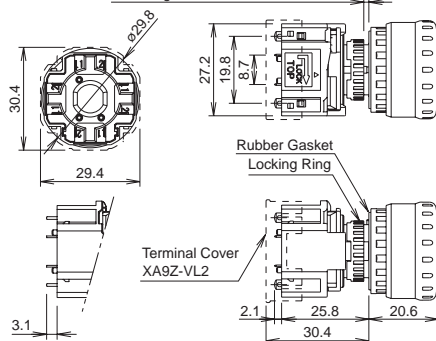

PC Board Terminal Type

Solder Terminal Type

Illuminated

Mounting Panel Thickness: 0.5 to 3.7

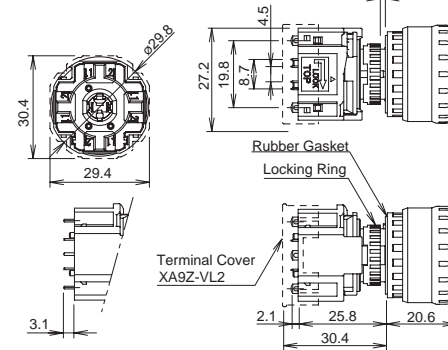

PC Board Terminal

Solder Terminal

Accessories

Description	Part Numbers
Replacement LED Unit: Solder Terminal	XA9Z-LED2R
Replacement LED Unit: PCB Terminal	XA9Z-LED2VR
Terminal Cover for contact block (solder terminal only)	XA9Z-VL2

LED Unit Internal Circuit

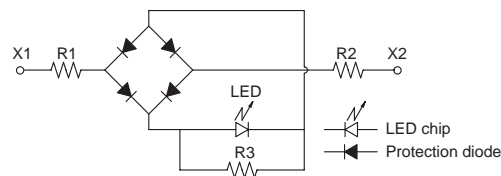

Door Interlock Switches

Enabling Switches

Barriers

AS-Interface Safety at Work

Accessories: Shroud

Part Number	Applicable Standards
 XA9Z-KG1	SEMI S2 Compliant (Approved by TUV)

Accessories: Nameplates

Size and Style	Part Number	Inner Ø	Outer Ø	Applicable E-Stop Mushroom Size
	16mm Blank ø43mm	16mm	43mm	29mm
	16mm "Emergency Stop" ø43mm	16mm	43mm	
	16mm Blank ø60mm	16mm	60mm	40mm
	16mm "Emergency Stop" ø60mm	16mm	60mm	

### Operating Instructions

#### Removing the Contact Block

First unlock the operator button. While pushing up the white bayonet ring, using a small screwdriver (width: 2.5 to 3 mm) if necessary, turn the contact block counterclockwise and pull out. **Do not exert excessive force when using a screwdriver, otherwise the bayonet ring may be damaged.**

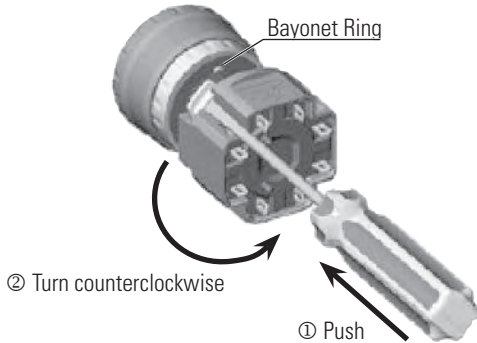

#### Notes for Removing the Contact Block

1. When the contact block is removed, the monitor contact (NO contact) is closed.
2. While removing the contact block, do not exert excessive force, otherwise the switch may be damaged.

#### Panel Mounting

Remove the locking ring from the operator and check that the rubber gasket is in place. Insert the operator from panel front into the panel hole. Face the side with the anti-rotation tab on the operator upward, and tighten the locking ring.

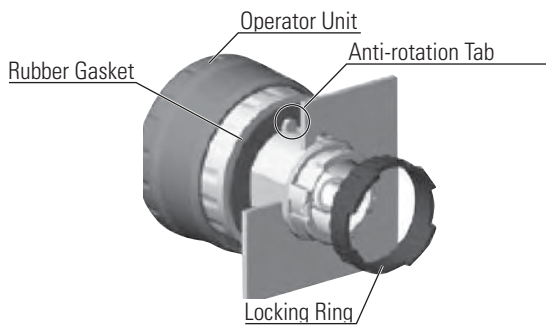

#### Notes for Panel Mounting

To mount XA emergency stop switches onto a panel, tighten the locking ring to a tightening torque of 0.88 N·m maximum using ring wrench MT-001. Do not use pliers. Do not exert excessive force, otherwise the locking ring may be damaged.

#### Installing the Contact Block

First turn the bayonet ring to the unlocked position.

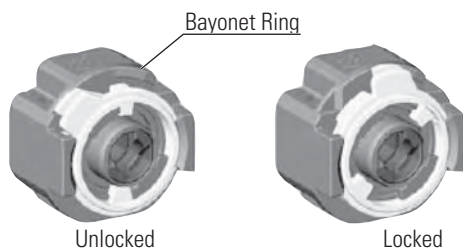

Align the small ▲ marking on the edge of the operator base with the TOP marking on the contact block. Press the contact block onto the operator and turn the contact block clockwise until the bayonet ring clicks.

#### Notes for Installing the Contact Block

Check that the contact block is securely installed on the operator. When the emergency stop switch is properly assembled, the bayonet ring is in place as shown below.

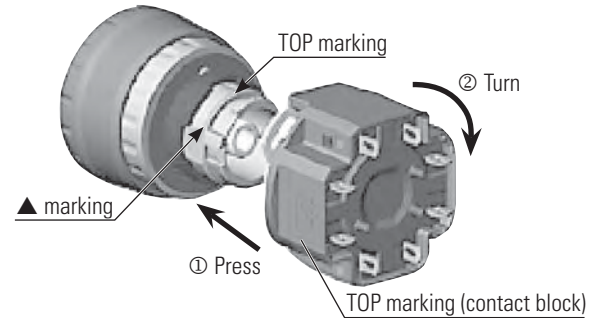

#### Removing the LED Unit

Pull out the LED unit while squeezing the latches on the LED unit using the LED unit removal tool (MT-101).

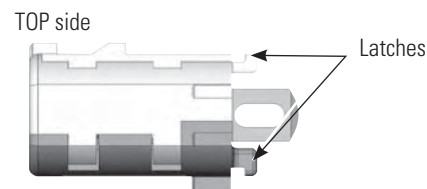
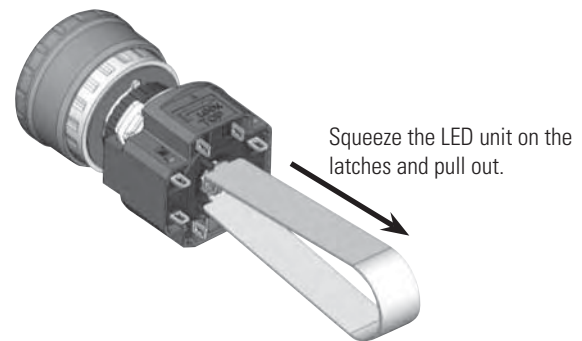

#### Installing the LED Unit

Align the top of the LED unit with the TOP marking on the contact block. Push the LED unit into the contact block.

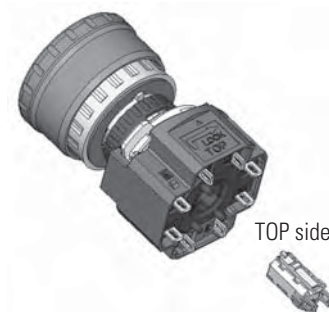

Operating Instructions, continued

Wiring

1. The applicable wire size is 16 AWG maximum.
2. Solder the terminal at a temperature of 310 to 350°C within 3 seconds using a soldering iron. Sn-Ag-Cu solder is recommended. When soldering, do not touch the switch with the soldering iron. Also ensure that no tensile force is applied to the terminals. Do not bend the terminals or apply excessive force to the terminals.
3. Use a non-corrosive rosin flux.
4. Because the terminal spacing is narrow, use protective tubes or heat shrinkable tubes to avoid burning of wire coating or short circuit.

PC Board Terminal Type

1. When mounting a contact block on a PC board, provide sufficient rotating space for the PC board when installing and removing the contact block.
2. When mounting an XA emergency stop switch on a PC board, make sure that the operator is securely installed.

About PC Board and Circuit Design

1. Use PC boards made of glass epoxy copper-clad laminated sheets of 1.6 mm in thickness, with double-sided through holes.
2. PC boards and circuits must withstand rated voltage and current, including instantaneous current and voltage at switching.
3. The minimum applicable load is 5V AC/DC, 1 mA.
4. Within the 2.8\* mm areas shown in the figure below, terminals touch the PC board, resulting in possible short circuit on the printed circuit. When designing a PC board pattern, take this possibility into consideration.

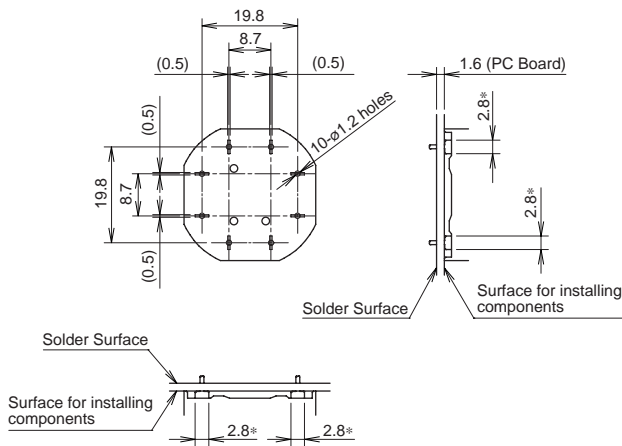

All dimensions in mm.

Installing Insulation Terminal Cover

To install the terminal cover (XA9Z-VL2), align the TOP marking on the terminal cover with TOP marking on the contact block, and press the terminal cover toward the contact block.

Note: For wiring, insert the wires into the holes in the terminal cover before soldering.

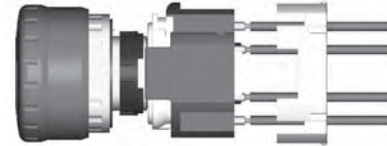

Contact Bounce

When the button is reset by pulling or turning, the NC main contacts will bounce. When pressing the button, the NO monitor contacts will bounce.

When designing a control circuit, take the contact bounce time into consideration (reference value: 20 ms).

Nameplate

When anti-rotation is not required, remove the projection from the nameplate using pliers.

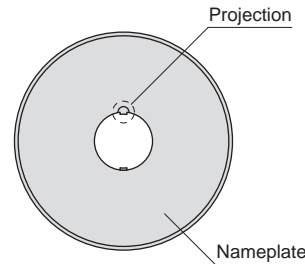

Handling

Do not expose the switch to excessive shock and vibration, otherwise the switch may be deformed or damaged, causing malfunction or operation failure.



Safety Precautions

- Turn off power to the XA series emergency stop switch before starting installation, removal, wiring, maintenance, and inspection of the relays. Failure to turn power off may cause electrical shock or fire hazard.
- Use the LED unit removal tool when replacing the LED unit to avoid burning your hands.
- Use wires of the proper size to meet the voltage and current requirements, and solder the wires correctly. If soldering is incomplete, the wire may heat during operation, causing a fire hazard.