

LED Timers – Codix 543

For use as a timer, hour meter or short-time meter

- Pulse width measurement (operating time)
- Time interval measurement (start/stop)



Power supply
AC/DC



Front bezel
dimensions



Wide temper-
ature range



High IP
protection
rating



Plug-in screw
terminal



Menu-driven
programming



Timer/ Hour
Meter

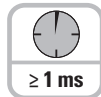

Resolution

Powerful

- **High accuracy**
Thanks to quartz time base
- **Robust housing**
IP 65 protection
- **LED display**
Very bright, 14 mm high
- **Time base can be set individually**
Hours, minutes or seconds – can be set even more precisely thanks to the max. 3 decimal places. Smallest attainable resolution: milliseconds
- **Fast start-up time**
Detects incoming pulses just 16 ms after being switched on → so no pulses are lost with a simultaneous motor start-up



User-friendly

- **Big keys**
Pressing either of the keys switches between displays
Can also be operated when using gloves
- **Easy to programme**
Easy menu-driven programming and operation
Possibility to enter the programming mode during operation, with authentication query

Universal

- **Individually programmable start/stop function**
By means of 2 start/stop inputs, up to 4 different measuring principles can be achieved, e.g. active or passive pulse width measurement, time interval measurement with one input or with separate inputs
- **Manual or electrical reset**
Tamper-proof, due to lockable reset function
- **User-programmable setpoint**
Start time at which the time counting should begin
- **AC or DC power supply**
With sensor power supply
- **Inputs**
As an alternative to the HTL inputs, devices with a 4 ... 30 V DC input level are available, for use as parallel displays for PLCs
- **Optional output**
1 Hz clock pulse for active time measurement

Applications for time and hour meters, short-time meters

- Time measurements such as hours run recording on all machines and plant, e.g. compressors, solariums, special lights and lamps.
- Accessories, OEM equipment or retro-fitting to production machine
- Measurement of short times on processes and procedures, time recording (stop-watch function) at sporting events
- Hours run recording for motor vehicles and time monitoring for rally vehicles

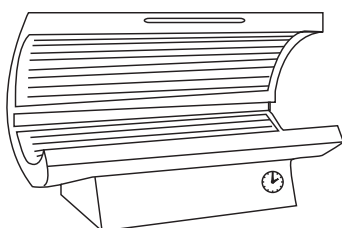

Hours run of UV lamps

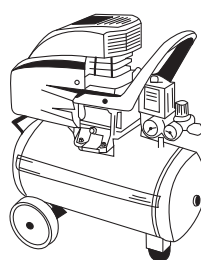

Operating hours

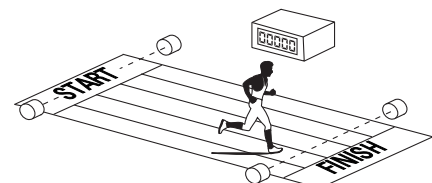

Short time measurement > 1 ms

LED Timers – Codix 543

Technical data:

Supply voltage:	10 ... 30 V DC, with reverse polarity protection 90 ... 260 V AC
Current consumption:	max. 50 mA, 6 VA
Display:	6-digit red 7-segment LED display; 14 mm [0.551"] high
Data backup:	EEPROM
Housing:	dimension 96 x 48 mm [3.78 x 1.89"] according to DIN 43 700; RAL 7021, grey
Polarity of Inputs:	programmable, npn or pnp for all inputs
Input resistance:	approx. 5 kΩ
Resolution:	0.001 s
Reset time:	5 ms
Input switching level (standard version):	DC-version: low: 0 ... 0.2 [0 ... 0.008"] x U _B [V DC] high: 0.6 [0.024"] x U _B ... 30 V DC AC-version: low 0 ... 4 V DC high 12 ... 30 V DC

Input switching level	low 0 ... 2 V DC
4 ... 30 V DV version:	high 4 ... 30 V DC
Voltage supply for sensors:	24 V DC ±15 %/100 mA at AC version
Power consumption: (Optocoupler)	max. 30 V, 10 mA
Ambient temperature:	-20 ... +65 °C [-4 ... 149 °F] non-condensing
Storage temperature:	-25 ... +70 °C [-13 ... 158 °F]
Altitude	up to 2000 m
Accuracy:	< 50 ppm
EMC:	Immunity to interference: EN55011 class B Emitted interference EN61000-6-2
Device safety:	design to: EN61010 Part 1 protection Class: 2 application area: Soiling Level 2
Protection:	IP 65 front side
Weight:	approx. 150 g [5.291 oz]

Block diagram:

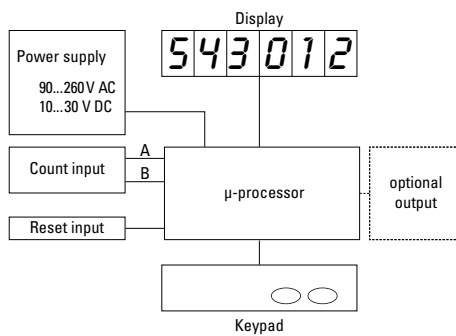

Connections:

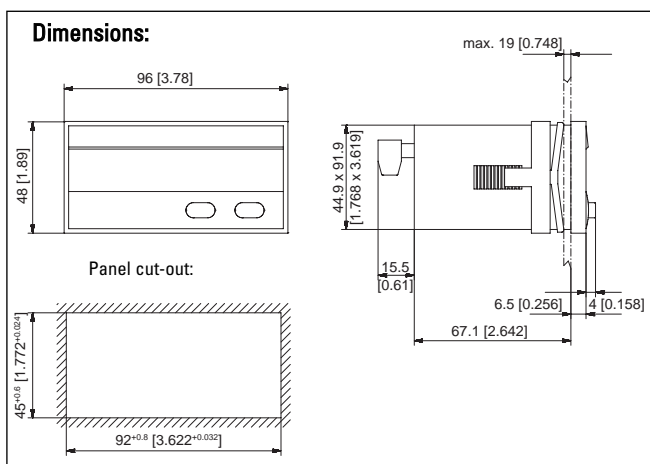
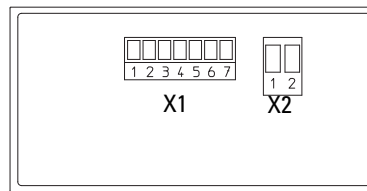

Connection: X2

Pin	AC-version	DC-version
1	90 ... 260 V AC	0 V DC (GND)
2	90 ... 260 V AC	10 ... 30 V DC

Connection: X1

Pin	AC-Version	DC-Version
1	Optocoupler output Emitter	
2	Optocoupler output Collector	
3	INP C (Frequency)	
4	INP B (Count)	
5	INP A (Count)	
6	GNDout	n.c.
7	+24 Vout	n.c.

Order code:

6.543.01X.XX0

Output
1 = Optocoupler output
2 = No output*

Input switch level
0 = Standard*
A = 4 ... 30 V DC level

Power supply
0 = 90 ... 260 V AC*
3 = 10 ... 30 V DC

* standard stock model

Delivery specification:

Digital display
Mounting clip
Gaskets
Multilingual operating instructions

Replacement parts:

7-pin screw terminal RM 3,81 1 ... 7: N100387
2-pin screw terminal RM 5,08 1 ... 2: N100133

LED Multifunction Counters – Codix 544

programmable as:

- Pulse counter
- Position display
- Frequency / speed display
- Timer/ short time meter



Power supply
AC/DC



Front bezel
dimensions



Wide temper-
ature range



High IP
protection
rating



Plug-in screw
terminal



Menu-driven
programming



Pulse counter/
Totaliser



Position
display



Frequency
meter/
Tachometer



Timer/
Hour Meter



Frequency
meter HRA

Powerful

- **Fast count input and frequency input**
Input frequency max. 60 kHz
- **Robust housing**
IP 65 protection
- **LED display**
Very bright, 14 mm high
- **HRA – High Rate Accuracy System**
Frequencies up to 38 Hz are calculated using time-interval (period duration) measurement.
Frequencies > 38 Hz are calculated using a special time base (gate time) measurement. A very high accuracy of < 0.1% is achieved, even with very short gate times. The resulting measurement is available after a max. of 50 ms.
- **Fast start-up time**
Detects incoming pulses just 16 ms after being switched on → so no pulses are lost with a simultaneous motor start-up



User-friendly

- **Big keys**
Can also be operated when using gloves
- **Easy to programme**
Easy menu-driven programming and operation
Possibility to enter the programming mode during operation, with authentication query

Universal

- **Individually programmable scaling**
Multiplication and division factor (0.0001 to 99.9999), to display corresponding engineering units, e.g. position in 1/10 mm and speed in RPM
- **4 different count input modes**
2-channel input for detecting count direction, difference or adding mode, quadrature x1, x2 or x4
- **Frequency measurement**
Display in 1/min or 1/sec
- **Time counting**
Pulse width or time interval measurement in hours, minutes or seconds, as well as real-time display
- **AC or DC power supply**
With sensor power supply
- **Inputs**
As an alternative to the HTL inputs, devices with a 5 V DC input level are available, for use as parallel displays for PLCs.
- **Optional output**
Zero signal for position and count, zero-speed monitoring, 1 Hz clock pulse for active time measurement

Applications for Multi-function Display

- Counting tasks such as quantity and piece counting, measuring and recording of speed and of operating and processing times
- Piece counting or tool-life measurement on die cutters, presses, extruders, wood-working machines, drilling machines,

pick-and-place machines, guillotines, special-purpose vehicles etc.

- Positioning tasks on processing machines, such as sawing machines, milling machines, bending and folding machines, etc.

- Production data acquisition by means of piece counting (using difference or adding), or measurement of production times or production speeds.
- Totalizing flow, quantity and other scaleable media, or display of current flow rates.

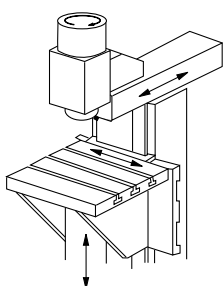

Position or rotary speed on milling machine

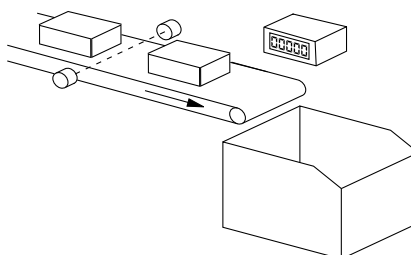

Piece count on conveyor or production speed

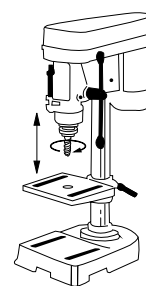

Drilling machine head, speed or drilling depth

LED Multifunction Counters – 544

Technical data:

Supply voltage:	10 ... 30 V DC, with reverse polarity protection
(galvanically isolated)	90 ... 260 V AC
Current consumption:	max. 50 mA, 6 VA
Display:	6-digit 7-segment red LED display; 14 mm high [0.551"]
Data backup:	EEPROM
Housing:	dimension 96 x 48 mm [3.78 x 1.89"] according to DIN 43 700; RAL 7021, grey
Polarity of Inputs:	programmable, npn or pnp for all inputs
Input resistance:	approx. 5 kΩ
Counting frequency*:	60 kHz, can be damped to 30 Hz. For position display max. 25 kHz
Minimum reset pulse time: :	5 ms
Display range timer:	0.001 s ... 999999 h
Weight:	approx. 150 g [5.291 oz]

*for further specifications please refer to the manual

Block diagram:

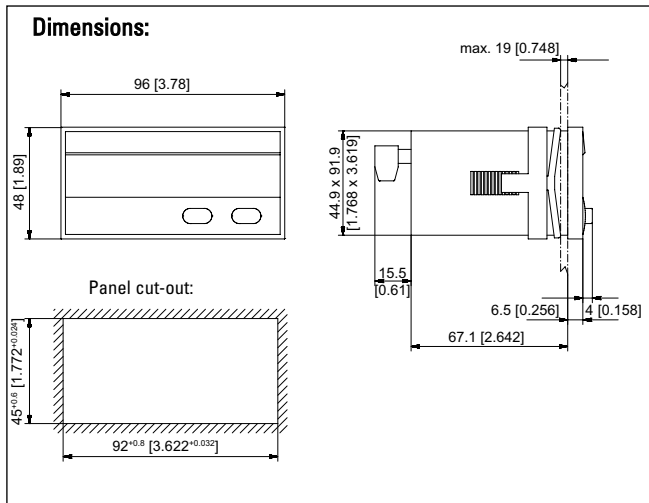
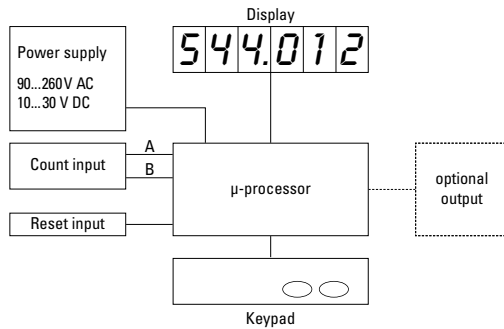

Order code:

6.544.01X.XX0

Output	Input switching level
1 = Optocoupler output	0 = Standard level*
2 = No output*	A = 4 ... 30 V DC level
Further stock model	Voltage supply
6.544.011.000	0 = 90 ... 260 V AC*
	3 = 10 ... 30 V DC*

* standard stock model

Input switching level (standard version):	DC-version	low: 0 ... 0.2 [0 ... 0.008"] x UB [V DC]
	AC-version	high: 0.6 x [0.024"] UB ... 30 V DC
Input switching level 4 ... 30 V DC version:	low: 0 ... 2 V DC	high: 4 ... 30 V DC
	Voltage supply for sensors: 24 V DC ±15 %/100 mA at AC-versions	
Accuracy:	tachometer:	<0,1 %
	timer:	< 50 ppm
Ambient temperature:	-20 ... +65 °C [-4 ... 149 °F] non condensing	
Storage temperature:	-25 ... +70 °C [-13 ... 158 °F]	
Altitude:	up to 2000 m	
EMC:	Emitted interference:	EN55011 Class B
	Immunity to interference:	EN61000-6-2
Device safety:	design to:	EN61010 Part 1
	protection Class:	2
	application area:	Soiling Level 2
	protection:	IP65 from front

Connections:

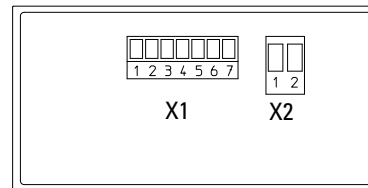

Connection: X2:

Pin	AC-version	DC-version
1	90 ... 260 V AC	0 V DC (GND)
2	90 ... 260 V AC	10 ... 30 V DC

Connection X1:

Pin	AC-version	DC-version
1	Optocoupler-output Emitter	
2	Optocoupler-output Collector	
3	Set	
4	INP B	
5	INP A	
6	GNDout	n.c.
7	+24 Vout	n.c.

Delivery specification:

Digital display	2 screw terminals
Mounting clip	Multilingual operating instructions
Gasket	

Delivery specification:

Digital display	2 screw terminals
Mounting clip	Multilingual operating instructions
Gasket	

Universal with dual functions **CODIX 54U**

4 dual functions in one device
 > solves all applications where 2 different values must be displayed simultaneously.

- Counter with 2 totalizing ranges
- Totaliser and time counter
- Totaliser and frequency counter
- Timer with 2 time ranges

10 ... 260V	DIN 48 x 96	-20° +65°	IP 65	Plug-in screw terminal	Menu-driven programming	max. 60 kHz	1/sec 1/min	Timer/ Hour Meter	HRA
Power supply AC/DC	Front bezel dimensions	Wide temperature range	High IP protection rating			Pulse counter/ Totaliser	Frequency meter/ Tachometer		Frequency meter HRA

Powerful

- **Fast count input**
Input frequency max. 60 kHz
- **Robust housing**
IP 65 protection
- **LED display**
Very bright, 14 mm high
- **HRA – High Rate Accuracy System**
Frequencies up to 38 Hz are calculated using time-interval (period duration) measurement.
Frequencies > 38 Hz are calculated using a special time base (gate time) measurement. A very high accuracy of > 0.1% is achieved, even with very short gate times. The resulting measurement is available after a max. of 50 ms.
- **Fast start-up time**
Detects incoming pulses just 16 ms after being switched on – so no pulses are lost with a simultaneous motor start-up



User-friendly

- **Big keys**
Can also be operated when using gloves
- **Easy to programme**
Easy menu-driven programming and operation
Possibility to enter the programming mode during operation, with authentication query
Pressing the right key switches between displays

Universal

- **Individually programmable scaling**
Multiplication and division factor (0.0001 to 99.9999), to display corresponding engineering units, e.g. position in 1/10 mm and speed in RPM.
- **Separate factors for frequency- and pulse counting**
- **AC or DC power supply**
With sensor power supply
- **Inputs**
As an alternative to the HTL inputs, devices with a 5 VDC input trigger level are available, for use as parallel displays for PLCs
- **Timer specials**
Timer or hours-run meter with various Start Stop measurements, time range settings in hours, minutes or seconds, with decimal point. Resolutions up to 1/1000 can be programmed

Applications for dual functions

- **Pulse and frequency (speed)**
e.g. production data acquisition: total piece count and speed on OEM equipment, flow rate measuring systems – total flow and current flow
- **2 pulse counters**
Measurement of batch and total piece count or of daily production count and total count values

- **Pulse and time (Maintenance counter)**
Used in the lift industry as trip counters and hours-run meters and on production machines for piece and time counting, flow and time measurement, materials handling time and quantities

- **2 timers**
Measurement of total time and order-specific times, maintenance intervals and total time, time of day and total time

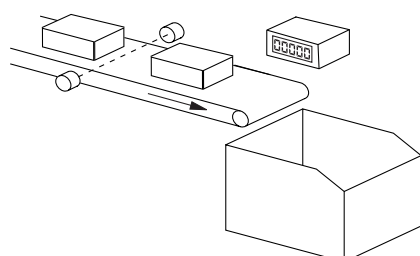

Piece count on conveyor and production speed

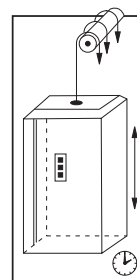

Trip counter and hours-run

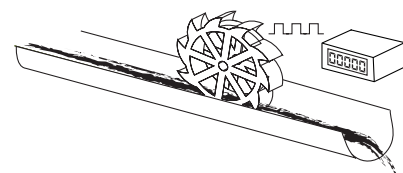

Flow rate and total volume

Universal with dual functions **CODIX 54U**

Technical data:

Supply voltage:	10 ... 30 V DC, with reverse polarity protection 90 ... 260 V AC
Current consumption:	max. 50 mA, 6 VA
Display:	6-digit 7-segment red LED display; 14 mm [0.551"] high
Data backup:	EEPROM
Housing:	Dimension 96 x 48 mm [3.78 x 1.89"] according to DIN 43 700; RAL 7021, grey
Polarity of Inputs:	programmable, npn or pnp for all inputs
Input resistance:	approx. 5 kΩ
Counting frequency*:	60 kHz, can be damped to 30 Hz depending on operating mode
Display range:	0.001 s ... 999999 h
Reset time:	5 ms
Input switching level (standard version):	DC-version: Low: 0 ... 0.2 [0 ... 0.008"] x U _B [V DC] High: 0.6 [0.024"] x U _B ... 30 V DC

	AC-version: Low 0 ... 4 V DC High 12 ... 30 V DC
Input switching level (5 V version):	Low 0 ... 2 V DC High 4 ... 30 V DC
Voltage supply for sensors:	24 V DC ±15 %/100 mA at AC version
Accuracy:	<0.1 % (Frequency display/Rate meter) <50 ppm (Timer)
Ambient temperature:	-20 ... +65 °C [-4 ... 149 °F] non-condensing
Storage temperature:	-25 ... +70 °C [-13 ... 158 °F]
EMC:	according to EC EMC directive 89/36/EWG
Emitted interference:	EN 61000-6-4/EN 55011 class B
Immunity to interference:	EN 61000-6-2
Protection:	IP65 from front
Weight:	approx. 150 g [5.291 oz]

*for further specifications please refer to the manual

Block diagram:

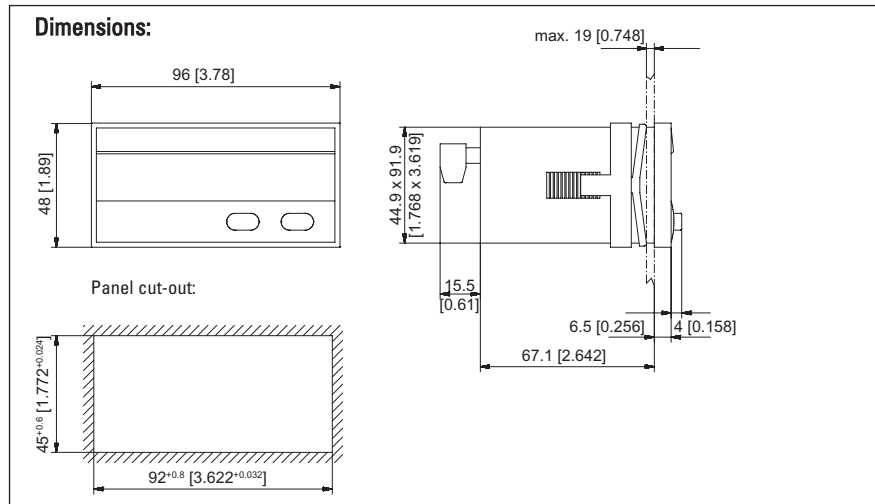
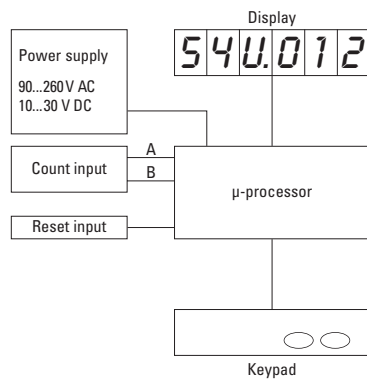

Order code:

6.54U.012.XX0

Input switching level
0 = Standard*
A = 5 V level

Power supply
0 = 90 ... 260 V AC*
3 = 10 ... 30 V DC

Connections:

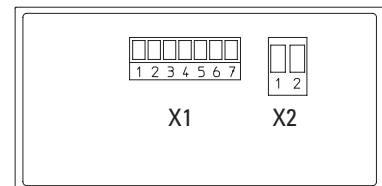

Connection: X2

Pin	AC-version	DC-version
1	90 ... 260 V AC	0 V DC (GND)
2	90 ... 260 V AC	10 ... 30 V DC

Connection: X1

Pin	AC-Version	DC-Version
1	n.c.	
2	n.c.	
3	Reset	
4	INP B	
5	INP A	
6	GNDout	n.c.
7	+24 Vout	n.c.

Delivery specification:
Digital display
Mounting clip

Seal
Multilingual operating instructions