

Rotary Measuring Technology

Incremental encoders



Universal, Type 580X (Shaft) / 582X (Hollow shaft)



- Sturdy model to industry standard, ø58 mm housing
- Many variations, also customized versions
- Short-circuit proof outputs
- Reverse connection protection (at $U_B = 10 \dots 30 \text{ V DC}$)
- Highly flexible PUR-cable
- Resolution up to 36000 ppr
- High shaft load

Shaft/hollow shaft

- 5800/5820: Standard
- 5803/5823: High temperature up to 110 °C
- 5804/5824: Voltage sine wave outputs
- 5805: High resolution up to 36000 ppr
- 5826: Stainless steel housing

Mechanical characteristics:

Speed with seal:	Shaft version max. 12000 min ⁻¹ Hollow shaft version ⁵⁾ max. 000 min ⁻¹
Speed without seal:	Hollow shaft version max. 12000 min ⁻¹
Rotor moment of inertia:	Shaft version approx. $1.8 \times 10^{-6} \text{ kgm}^2$ Hollow shaft version approx. $6 \times 10^{-6} \text{ kgm}^2$
Starting torque:	Shaft version < 0.01 Nm Hollow shaft version < 0.05 Nm
Radial load capacity of shaft*:	80 N
Axial load capacity of shaft*:	40 N
Weight:	approx. 0.4 kg
Protection acc. to EN 60 529:	IP 65, IP 66 for type 5826
EX approval for hazardous areas:	optional zone 2 and 22
Working temperature:	-20 °C ... +85 °C ¹⁾²⁾³⁾ 5803/5823: -20 ... + 105 °C
Shaft:	stainless steel
Shock resistance acc. to DIN-IEC 68-2-27	1000 m/s ² , 6 ms
Vibration resistance acc. to IEC 68-2-6:	100 m/s ² , 10...2000 Hz

1) Constant flexing: -20 ... +70 °C

3) Hollow shaft version with seal: -20 ... +80 °C

2) Non-condensing

5) For continuous operation 3000 min⁻¹, ventilated

Electrical characteristics RS422/Push-pull:

Output circuit:	RS 422 (TTL-compatible)	RS 422 (TTL-compatible)	Push-pull	Push-pull
Supply voltage:	5 V (±5%) or 10 ... 30 V DC	5 ... 30 V DC	10 ... 30 V DC	5 ... 30 V DC
Power consumption (no load) without inverted signal:	–	–	typ. 55 mA / max. 125 mA	typ. 55 mA / max. 125 mA
Power consumption (no load) with inverted signals:	typ. 40 mA / max. 90 mA	typ. 40 mA / max. 90 mA	typ. 80 mA/ max. 150 mA	typ. 80 mA/ max. 150 mA
Permissible load/channel:	max. ±20 mA	max. ±20 mA	max. ±30 mA	max. ±30 mA
Pulse frequency:	max. 300 kHz	max. 300 kHz	max. 300 kHz	max. 300 kHz
Signal level high:	min. 2.5 V	min. 2.5 V	min. UB-2.5 V	min. UB-1.5 V
Signal level low:	max. 0.5 V	max. 0.5 V	max. 2.0 V	max. 2.0 V
Rise time t_r	max. 200 ns	max. 200 ns	max. 1 µs	max. 1 µs
Fall time t_f	max. 200 ns	max. 200 ns	max. 1 µs	max. 1 µs
Short circuit proof outputs ¹⁾ :	yes ²⁾	yes ²⁾	yes	yes
Reverse connection protection at U_B :	5 V: no, 1 0 ... 30 V: yes	yes	yes	no
UL certified	File 224618			
Conforms to CE requirements acc. to EN 61000-6-1, EN 61000-6-4 and EN 61000-6-3				
RoHS compliant acc. to EU guideline 2002/95/EG				

1) If supply voltage correctly applied

2) Only one channel allowed to be shorted-out:

(If $U_B = 5 \text{ V}$, short-circuit to channel, 0 V, or +UB is permitted)
(If $U_B = 5-30 \text{ V}$, short-circuit to channel or 0 V is permitted)

Rotary Measuring Technology

Incremental encoders



Universal, Type 580X (Shaft) / 582X (Hollow shaft)

Electrical characteristics sine wave output:

Output circuit:	Sine wave	Sine wave
	U = 1 Vpp	U = 1 Vpp
Supply voltage:	5 V (±5%)	10 ... 30 V DC
Current consumption (no load) with inverted signals:	typ. 65 mA / max. 110 mA	typ. 65 mA / max. 110 mA
-3 dB frequency:	≤ 180 kHz	≤ 180 kHz
Signal level channels A/B:	1 Vpp (±20%)	1 Vpp (±20%)
Signal level channel 0:	0.1 ... 1.2 V	0.1 ... 1.2 V
Short circuit proof outputs ¹⁾ :	yes	yes
Reverse connection protection at UB:	no	yes
UL certified	File 224618	
Conforms to CE requirements acc. to EN 61000-6-1, EN 61000-6-4 and EN 61000-6-3		
RoHS compliant acc. to EU guideline 2002/95/EG		

¹⁾ If supply voltage correctly applied

Terminal assignment

Signal:	0 V	0 V Sensor ²⁾	+U _B	+U _B Sensor ²⁾	A	Ā	B	B̄	0	0̄	Schirm
12-pin. Connector, Pin:	10	11	12	2	5	6	8	1	3	4	PH ¹⁾
7-pin. Connector, Pin:	F	---	D	E	A	---	B	---	C	-	G
10-pin. Connector, Pin:	F	-	D	E	A	G	B	H	C	I	J
Cable colour: 5800, 5803, 5804, 5805, 5823, 5824, 5825:	WH	WH	BN	BN	GN	YE	GY	PK	BU	RD	
Cable colour: 5820, 5826:	WH	GY PK	BN	BU RD	GN	YE	GY	PK	BU	RD	

¹⁾ PH = Shield is attached to connector housing

²⁾ The sensor cables are connected to the supply voltage internally if long feeder cables are involved they can be used to adjust or control the voltage at the encoder

- If sensor cables are not in use, they have to be isolated or 0 V_{Sensor} has to be connected to 0 V and U_B_{Sensor} has to be connected to U_B

- Using RS 422 outputs and long cable distances, a wave impedance has to be applied at each cable end. **Isolate unused outputs before initial startup.**

Top view of mating side, male contact base:

12 pin plug

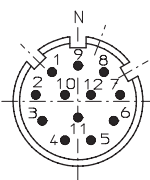

7 pin plug

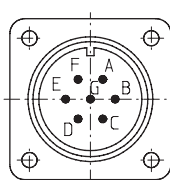

10 pin plug

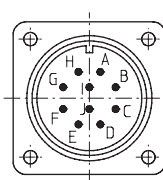

Dimensions shaft version:

Clamping flange ø 58
Flange Type 1

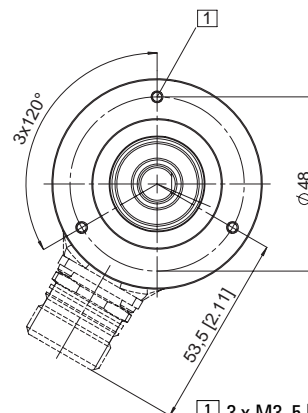
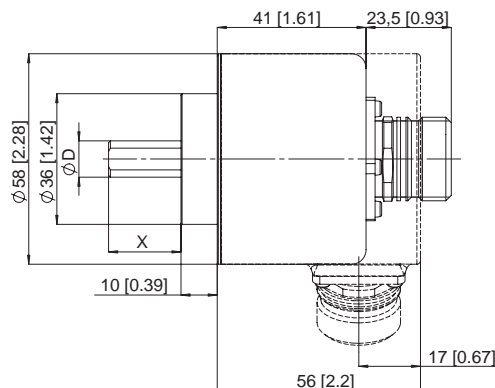

Mounting advice:

The flanges and shafts of the encoder and drive should not both be rigidly coupled together at the same time! We recommend the use of suitable couplings (see Accessories section).

1 3 x M3, 5 [0,2] deep

Rotary Measuring Technology

Incremental encoders



Universal, Type 580X (Shaft) / 582X (Hollow shaft)

Dimensions shaft version:

Synchronous flange $\varnothing 58$
Flange Type 2

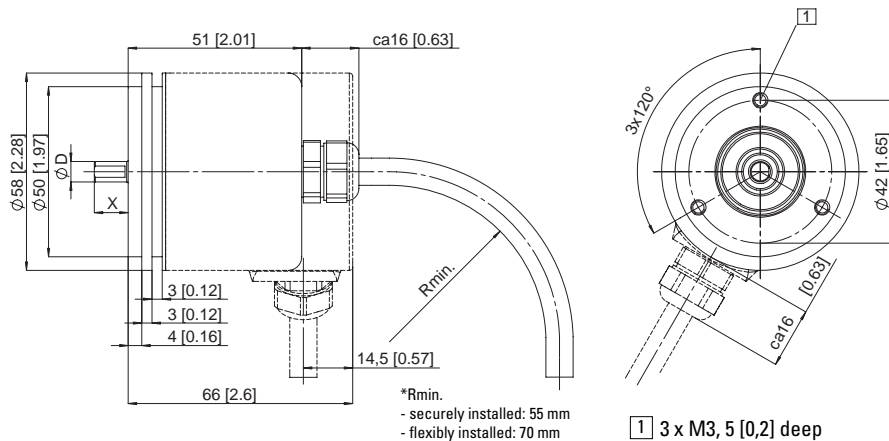

Order code shaft version:

8.580X.XXXX.XXXX

Type	00 = Standard 03 = High temperature 04 = Sine wave 05 = High resolution
Flange	1 = Clamping flange $\varnothing 58$ 2 = Synchronous flange $\varnothing 58$
Shaft ($\varnothing \times L$)	1 = $\varnothing 6 \text{ mm} \times 10 \text{ mm}$ 2 = $\varnothing 10 \text{ mm} \times 20 \text{ mm}$

Pulse rate	25, 50, 60, 100, 125, 200, 250, 256, 300, 360, 500, 512, 600, 720, 800, 1000, 1024, 1200, 1250, 1500, 2000, 2048, 2500, 3000, 3600, 4000, 4096, 5000 Type 5805: 6000, 7200, 8000, 8192, 9000, 10000, 18000, 36000 (e.g. 250 pulses => 0250) Other pulse rates available on request
------------	--

Type of connection	1 = Cable axial (1 m PUR-Cable) 2 = Cable radial (1 m PUR-Cable) 3 = axial 12 pin plug without mating connector 5 = radial 12 pin plug without mating connector W ¹⁾ = 7 pin plug, "MIL"-specified ²⁾ without mating connector, radial Y = 10pin plug, "MIL"-specified ²⁾ without mating connector, radial ¹⁾ only with output 7 ²⁾ only for type 5800
--------------------	--

Type of connection and supply voltage	Type 5800
4 = RS 422 (with inverted signal)	5 V supply voltage
5 = RS 422 (with inverted signal)	10 ... 30 V supply voltage
6 = Push-pull (with inverted signal)	10 ... 30 V supply voltage
7 = Push-pull (without inverted signal)	10 ... 30 V supply voltage
8 = Push-pull (without inverted signal)	5 ... 30 V supply voltage
9 = Push-pull (with inverted signal)	5 ... 30 V supply voltage
Y = RS 422 (with inverted signal)	5 ... 30 V Supply voltage
T = Push-Pull (with inverted signal)	5 ... 30 V supply voltage

Type 5803 and 5805
4 = RS 422 (with inverted signal)
5 V supply voltage
5 = RS 422 (with inverted signal)
10 ... 30 V supply voltage
6 = Push-pull (with inverted signal)
10 ... 30 V supply voltage
7 = Push-pull (without inverted signal)
10 ... 30 V Supply voltage
Type 5804
1 = Sine, 1 Vpp (with inverted signal)
5 V supply voltage
2 = Sine, 1 Vpp (with inverted signal)
10 ... 30 V Supply voltage

Preferred types are indicated in bold

Accessories:
Corresponding mating connector to connection type 3 or 5:
Order-No. 8.0000.5012.0000
Corresponding mating connector to connection type W:
Order-No. 8.0000.5052.0000
Corresponding mating connector to connection type Y:
Order-No. 8.0000.5062.0000

Cables and connectors, also pre-assembled, can be found in the chapter Counting Technology
Mounting attachments and couplings can be found in the Chapter Accessories

Rotary Measuring Technology

Incremental encoders



Universal, Type 580X (Shaft) / 582X (Hollow shaft)

Dimensions hollow shaft:
Flange Type 1 and 2

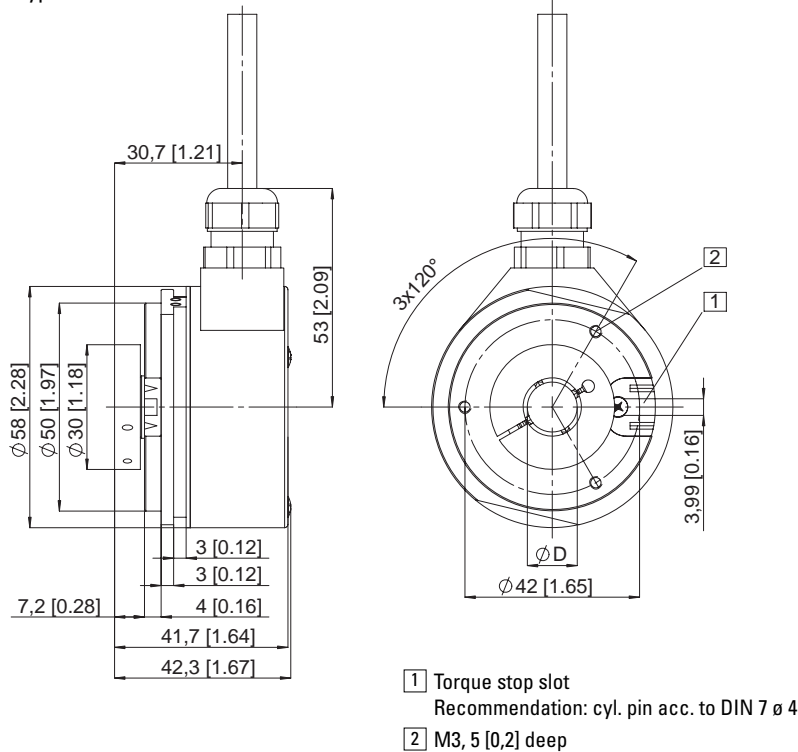

Flange Type 3 and 4 with stator coupling

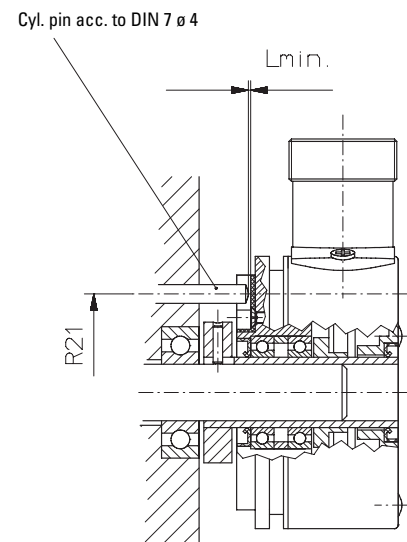
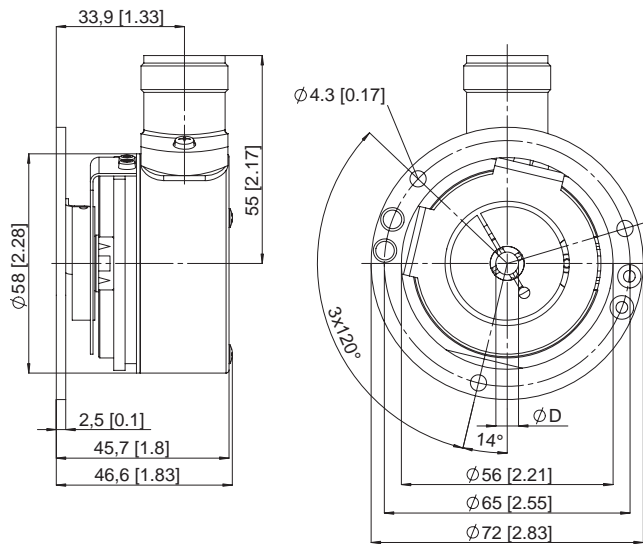

Note: minimum insertion depth $1.5 \times D_{\text{hollow shaft}}$

Mounting advice:

- 1) The flanges and shafts of the encoder and drive should not both be rigidly coupled together at the same time.
- 2) When mounting a hollow shaft encoder, we recommend using a torque stop pin that fits into the torque stop slot or a stator coupling.
- 3) When mounting the encoder ensure the dimension Lmin. is greater than the axial maximum play of the drive. Otherwise there is a danger that the device could mechanically seize up.

Universal, Type 580X (Shaft) / 582X (Hollow shaft)

Order code hollow shaft version:

8.582X.XXXX.XXXX

Type
20 = Standard
23 = High temperature
24 = Sine wave
25 = High resolution
26 = Stainless steel

Flange
1 = Flange for through shaft
2* = Flange for blind hollow shaft*
3* = Flange for through shaft and stator coupling
4* = Flange for blind hollow shaft and stator coupling length of drive shaft ≤ 30 mm

*not for type 5826

Hollow shaft**
1 = ø 6 mm without seal
2 = ø 6 mm with seal
3 = ø 8 mm without seal
4 = ø 8 mm with seal
5 = ø 10 mm without seal
6 = ø 10 mm with seal
7 = ø 12 mm without seal
8 = ø 12 mm with seal

For type 5826 only versions
6 and 8 are possible

Preferred types are indicated in bold

Pulse rate
25, 50, 60, 100, 125, 200, 250, 256, 300, 360, 500, 512, 600, 720, 800, 1000, 1024, 1200, 1250, 1500, 2000, 2048, 2500, 3000, 3600, 4000, 4096, 5000
Type 5825: 6000, 7200, 8000, 8192, 9000, 10000, 18000, 36000 (e.g. 250 pulses => 0250)
Other pulse rates available on request

Type of connection
1 = Cable radial (1 m PVC-cable)
2¹⁾ = radial 12pin plug without mating connector

¹⁾not for type 5826

Type of connection and supply voltage
Type 5820 and 5826

1 = RS 422 (with inverted signal) 5 V supply voltage
2 = Push-pull (without inverted signal) 10 ... 30V supply voltage
3 = Push-pull (with inverted signal) 10 ... 30V supply voltage
4 = RS 422 (with inverted signal) 10 ... 30 V supply voltage
5 = Push-pull (without inverted signal) 5 ... 30 V supply voltage
6 = Push-pull (with inverted signal) 5 ... 30 V supply voltage
7 = RS 422 (with inverted signal) 5 ... 30 V supply voltage
C* = Push-pull (7272 with inverted signal) 5 ... 30 V supply voltage

* For Type 5826 not available

Type 5823 and 5825

1 = RS 422 (with inverted signal) 5 V supply voltage
2 = Push-pull (without inverted signal) 10 ... 30V supply voltage
3 = Push-pull (with inverted signal) 10 ... 30V supply voltage
4 = RS 422 (with inverted signal) 10 ... 30 V supply voltage

Type 5824

1 = Sine, 1 Vpp (with inverted signal) 5 V supply voltage
2 = Sine, 1 Vpp (with inverted signal) 10 ... 30 V supply voltage

Accessories

Corresponding mating connector to
Type of connection 2,
12 pin: Order No. 8.0000.5012.0000
pin assignment cw

- Cables and connectors, also pre-assembled, can be found in the chapter Counting Technology
- Mounting attachments and couplings can be found in the Chapter Accessories

Mounting kit for hollow shaft encoder ø 58 mm:

Various mounting variations can be supplied

Delivery includes:

- 1 x parallel pin with thread
Order No. 8.0010.4700.0000
- 1 x mounting flanges
Order No. T.035.009
- Screw M3x5
Order No N.630.305
- 1 x long torque support slot
Order No. T.051.672

Complete set:
Order No. 8.0010.4600.0000

Stator coupling two wings

– For highly dynamic applications
Includes:

- 1x coupling two wings
- 2x 2 screws

Complete set:

Order No. 8.0010.4D00.0000

Tether arm short

Order No. 8.0010.4R00.0000