

Rotary Measuring Technology

Absolute encoders, Multiturn, optional with incremental track



Multiturn Type 5862 (Shaft) / 5882 (Hollow shaft) SSI or RS 485, programmable



- Electronic multiturn gear with intelligent sensing technology (IST)
- Integrative Technology
- Max. 4 programmable outputs* for the SSI version
- Programmable parameters include*: code type, resolution per revolution, total resolution, direction of rotation (cw or ccw), zero point
- Resolution: up to 8192 (13 bits) per revolution, 4096 (12 bits) revolutions
- Protection IP 65
- Short-circuit proof at 5 V DC
- With optional incremental track 2048 ppr.
- Hollow shaft version: Only 40.5 mm clearance needed, thus lower profile than incremental encoders

* With optional programming kit (Ezturn®) see accessories

Mechanical characteristics:

Speed ¹⁾ :	max. 6 000 min ⁻¹
Rotor moment of inertia:	Shaft version: approx. 1.8×10^{-6} kgm ² Hollow shaft version: approx. 6×10^{-6} kgm ²
Starting torque shaft version:	Shaft version: < 0.01 Nm Hollow shaft version: < 0.05 Nm
Radial load capacity of shaft: ²⁾	80 N
Axial load capacity of shaft: ²⁾	40 N
Weight:	approx. 0.4 kg
Protection acc. to EN 60 529:	IP 65
EX approval for hazardous areas:	optional zone 2 and 22
Working temperature:	-20° C ... +70 °C ³⁾
Shaft:	stainless steel
Shock resistance acc. to DIN-IEC 68-2-27	2500 m/s ² , 6 ms
Vibration resistance acc. to DIN-IEC 68-2-6:	100 m/s ² , 10 ... 2000 Hz

¹⁾ Hollow shaft version: continuous operation 3000 min⁻¹

²⁾ For shaft version only (at shaft end)

³⁾ Non-condensing

Electrical characteristics:

Interface type:	Synchronous-Serial (SSI) with outputs
General information	
Supply voltage (U _B):	5,0 ... 30 V DC ³⁾
Current consumption type (no load):	89 mA
max (no load):	138 mA
Short circuit proof outputs: ¹⁾	yes ²⁾
Reverse connection protection at U _B :	yes
SSI-Interface:	
Output driver:	RS 485
Permissible load/channel:	max. +/-20 mA
Update rate for position data:	approx. 1600/s
SSI pulse rate min./max./pulse frequency:	100 kHz/500 kHz
Signal level high:	typ. 3.8 V
Signal level low (I _{Last} = 20 mA):	typ. 1.3 V
Rise time t _r (without cable):	max. 100 ns
Fall time t _f (without cable):	max. 100 ns
Control inputs:	
Voltage:	5 ... 30 V DC = U _B
(V/R, SET) response time:	10 ms
Signal level: low	max. 25% U _B
high	min. 60% U _B , max. U _B
Max. current input	≤0.5 mA

The programmable SSI versions are available in 3 variants:

Order code Interface 2:

Version with 4 programmable outputs

Order code Interface 4:

Version with incremental outputs A, \bar{A} , B, \bar{B} (no programmable outputs)

Order code Interface 9:

Version with 2 programmable outputs and 2 sensor outputs for 0 V and +U_B for controlling the supply voltage on the encoder.

Status outputs:	Output driver:	Push-Pull
	max. permissible load:	±9.0 mA
	Signal level high:	min. U _B - 3.0 V
	low:	max. 1.5 V
	Rise time:	max. 240 µs
	Fall time:	max. 300 µs

Incremental outputs (A/B):	
Output driver:	RS422 compatible
Pulse frequency (max.):	200 kHz
Signal level high:	4.5 V
Signal level low (I _{Last} = 20 mA):	0.5 V
Rise time (without cable):	max. 200 ns
Fall time (without cable):	max. 200 ns

Conforms to CE requirements acc. to EN 61000-6-1, EN 61000-6-4 and EN 61000-6-3

Performance against magnetic influence acc. to EN61000-4, 5

UL certified File 224618

RoHS compliant acc. to EU guideline 2002/95/EG

¹⁾ If U_B supply voltage correctly applied U_B

²⁾ Only one channel at a time:

If U_B = 5 V DC, short-circuit to output, 0 V and + U_B is permitted.
If U_B < 5 V DC short-circuit to output and 0 V is permitted.

³⁾ The supply voltage at the encoder input must not be less than 4.75 V (5 V - 5%)

Rotary Measuring Technology

Absolute encoders, Multiturn, optional with incremental track



Multiturn Type 5862 (Shaft) / 5882 (Hollow shaft) SSI or RS 485, programmable

Control inputs:

F/R input for change of direction:

The encoder can output increasing code values when the shaft is rotated either clockwise or counter-clockwise (when looking from the shaft side).

There are two methods for selecting the appropriate option:

1. Via a hardware configuration of the F/R input BEFORE powering up the encoder
2. By programming the device using the Kübler "Ezturn®" programming tool.

The following table shows the function selection dependent on hardware and software settings:

Hardware configuration of the F/R input:

Hardware configuration of the F/R input	Programmed selection using the Ezturn® programming tool	Function: increasing code value when the shaft is in the following direction:
"low" (0V) on the F/R input (=cw)	cw	cw
"high" (+UB) on the F/R input (= ccw)	cw	ccw
"low" (0V) on the F/R input (=cw)	ccw	ccw
"high" (+UB) on the F/R input (= ccw)	ccw	ccw

Notes:

- Any hardware configuration of the F/R input must take place BEFORE powering up the encoder!
- If the F/R input is not configured, then a 0V configuration will apply (default condition)!
- If the direction of rotation is changed due to the F/R configuration, without activating the SET function again, and if the encoder is also then powered up again, a new position value may be outputted, even if the physical shaft position of the encoder has not moved! This is due to internal conversion processes.

The start-up procedure for the encoder should therefore follow this sequence:

1. Determine the count direction of the encoder either via the F/R input or via programming
2. Apply power to the encoder
3. Activate the SET function, if desired (see SET input below)

- If using a cable wire to configure the F/R input, then for EMC reasons the wire should not remain open but should be tied either to 0V or UB!
- The response time of the F/R input with UB = 5 ... 30 V DC power supply is 10 ms.

SET input:

This input is used for a one-time alignment (zeroing) of the encoder immediately after installation. A high control pulse (+UB) applied to this input for a minimum of 10 ms will reset the current encoder position to the pre-programmed setpoint value.

The programming of the setpoint can be carried out with Kübler's Ezturn® programming software or can, on request, be done in advance at the factory. The default value is zero. However any value within the encoder's measuring range can be defined.

Notes:

- The SET function should only be implemented when the encoder shaft is at rest.
- For the duration of the SET pulse the SSI interface does not function and therefore does not output any valid position values! In order to avoid malfunctions, no SSI clock pulse should occur during the SET pulse.
- If a cable wire is used to configure the SET input, then for EMC reasons the wire should not remain open but should if at all possible be tied to 0 V, provided no SET pulse is triggered!
- The response time of the SET input with +UB = 5 ... 30 V DC power supply is 10 ms.

Encoder outputs¹⁾

Output	Default-function:
A1:	battery control ²⁾
A2:	not activated ²⁾
A3:	not activated ²⁾³⁾
A4:	not activated ²⁾³⁾

The outputs are not activated in the factory setting (default). They can be activated and defined with the optional Ezturn® programming software e.g. limit switch, overspeed and temperature control etc.
3) with the order code Interface 9 assigned to the sense outputs.

1) not available for versions with incremental track
2) programmable with the optional programming software Ezturn®

Functionality of the Ezturn® software

- Setting of the communication parameters
- RS232 encoder/PC interface
- Setting of a drive factor by means of the modification of the resolution per revolution, the number of revolutions and the total resolution
- Programming of the direction of rotation and code type
- Setting of a preset/electronic zero point
- Setting of diagnostic functions
- Setting of the outputs A1 ... A4
 - Limit switch values, max. 2
 - Alarm and status information
 - Battery monitoring
- Limiting max. number of bits to interface with PLCs
- Diagnostics and information for the set-up operation
- Data transmission from the PC to the encoder and inversely, also during operation
- Print-out of the current data and set parameters
- Convenient position output with the current set data
- Terminal operation for direct instructions via the keyboard
- Diagnostics of the encoder connected

Absolute Encoders

Rotary Measuring Technology

Absolute encoders, Multiturn, optional with incremental track



Multiturn Type 5862 (Shaft) / 5882 (Hollow shaft) SSI or RS 485, programmable

Terminal assignment SSI Synchronous Serial interface with 12pin plug

Signal :	0V	+UB	+T	-T	+D	-D	ST	VR	A1	A2	A3 ¹⁾	A4 ¹⁾	⏏
Interface 9:										0 V _{sense}	+UB _{sense}		
Pin:	1	2	3	4	5	6	7	8	9	10	11	12	PH
Col.:	WH	BN	GN	YE	GY	PK	BU	RD	BK	VT	GY PK	RD BU	

T: Clock signal
D: Data signal
ST: SET input. The current position value is stored as new zero position (or the actual value is set to the preset value when using the programmable version).

VR: Up/down input. As long as this input is active, decreasing code values are transmitted when shaft turning clockwise.
PH: Plug housing
Isolate unused outputs before initial start-up

Interface 9
A1,A2,A3,A4: outputs, can be modified using Ezturn®
¹⁾With the order code Interface 9 these outputs are assigned to the sense outputs. The sensor circuits are internally tied to the power supply. Special power supply units control the voltage drop in long cable runs via the voltage feedback. If the circuits are not being used, then they should be individually isolated and not connected.

Terminal assignment (RS485 interface 12 pin plug):

Signal :	0V	+UB	T/R-	T/R+	Term ²⁾	Term ²⁾		VR					⏏
Pin	1	2	3	4	5	6	7 ¹⁾	8	9	10	11	12	PH
Col.:	WH	BN	GN	YE				RD					

R = Receive-channel
T = Transmit-channel
VR: Up/down input. As long as this input (High-Level = + UB) is active, decreasing code values are transmitted when shaft turning clockwise.
PH = Plug housing

¹⁾ There is no SET input for the P3001 version but it can likewise be implemented using the command "<ESC> QP" (Write preset).

²⁾ For the version with external termination: if the termination is desired (terminating resistor 120 Ohm), then both connections are to be tied together by means of a jumper (0 Ohm).

SSI interface with incremental track (A/B):

Signal :	0V	+UB	+T	-T	+D	-D	ST	VR	\bar{B}	B	\bar{A}	A	⏏
Pin	1	2	3	4	5	6	7*	8	9	10	11	12	PH

Top view of mating side::

12 pin plug

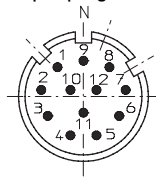

Dimensions shaft version

Clamping flange

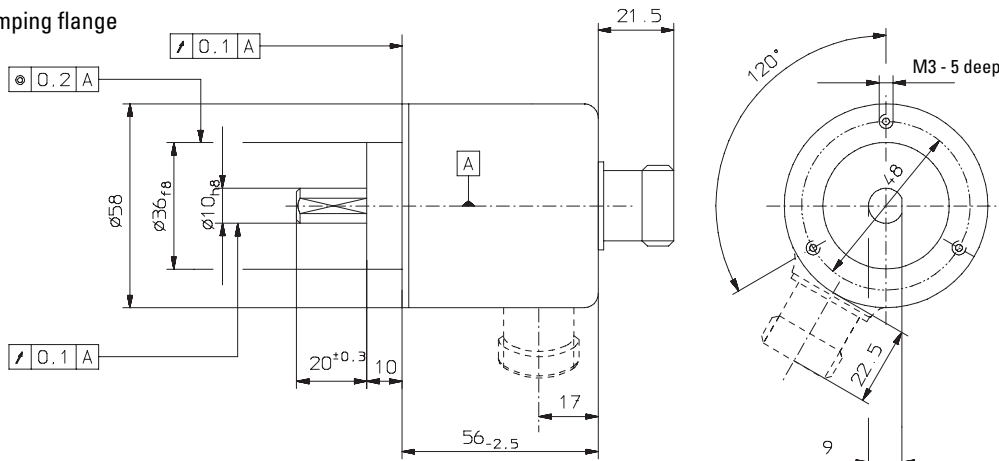

Rotary Measuring Technology

Absolute encoders, Multiturn, optional with incremental track



Multiturn Type 5862 (Shaft) / 5882 (Hollow shaft) SSI or RS 485, programmable

Dimensions shaft version:

Synchronous flange

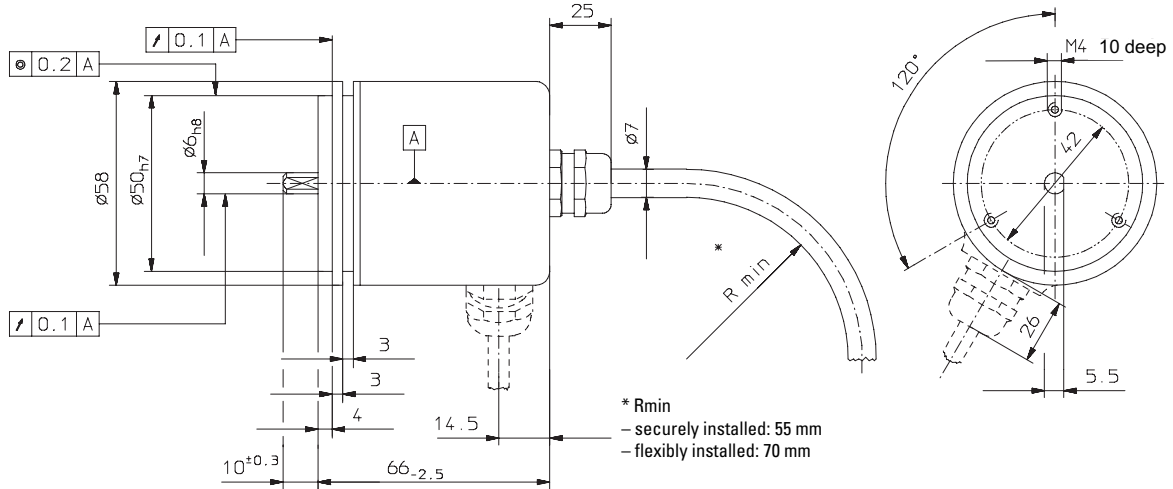

Order code shaft version:

8.5862.XXXX.XXXX

Type		SSI-Interface*
Flange	1 = Clamping flange 2 = Synchronous flange	2001 = 4096 x 4096 (24-Bit), Binary 2002 = 8192 x 4096 (25-Bit), Binary 2003 = 4096 x 4096 (24-Bit), Gray 2004 = 8192 x 4096 (25-Bit), Gray
Shaft (ø x L)	1 = ø 6 mm x 10 mm 2 = ø 10 mm x 20 mm	RS 485-Interface, half-duplex 3001 = ESC protocol, max. 19200 baud
Interface	2 = SSI 5 ... 30 V DC, with 4 status outputs 3 = RS 485, half-duplex 5 ... 30 V DC internal termination 5 = SSI, 5 ... 30 V DC, with incremental tracks A, B A, B, 2048 ppr. 7 = RS 485, half duplex 5 ... 30 V DC, external termination 9 = SSI 4.75 ... 30 V DC. with 2 status outputs and 2 sensor outputs for monitoring the supply voltage on the encoder.	*This factory set (default) resolution can be re-programmed by using the Ezturn® software.
Type of connection	1 = Axial cable (1 m PVC-cable) 2 = Radial cable (1 m PVC-cable) 3 = Axial 12 pin plug 4 = Radial 12 pin plug	Accessories: Corresponding mating connector to connection type 3 and 4 Order code 8.0000.5012.0000 Programming kit Ezturn® includes - Interface converter - Connection cable with the interface converter encoder – PC - 90-250 V AC power supply - CD-ROM with Ezturn® software

Preferred types are indicated in bold



Order code 8.0010.9000.0004

Absolute Encoders

Rotary Measuring Technology

Absolute encoders, Multiturn, optional with incremental track



Multiturn Type 5862 (Shaft) / 5882 (Hollow shaft) SSI or RS 485, programmable

Dimensions hollow shaft version:

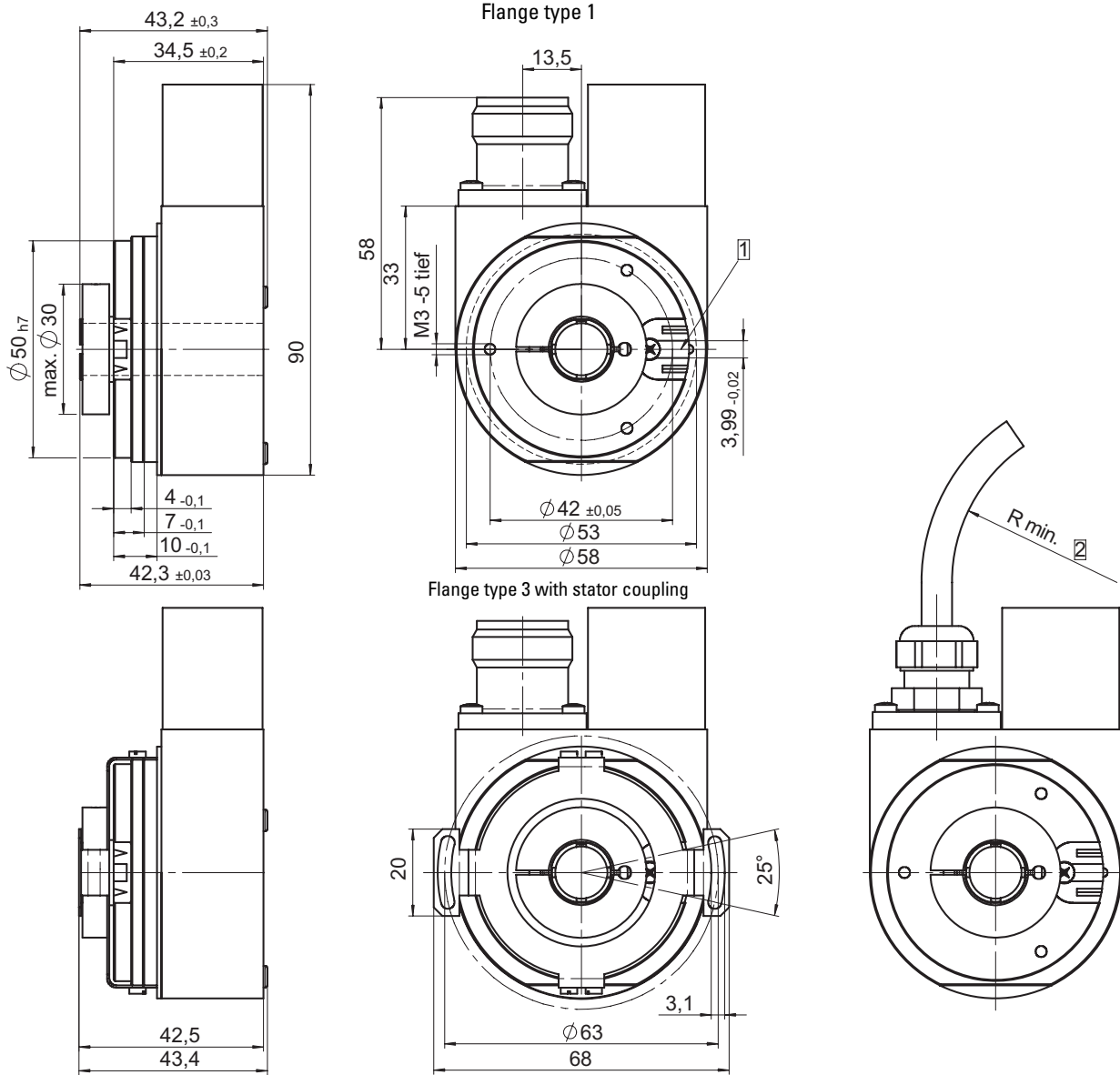

- 1 torque stop slot
Recommendation: Cyl. pin. acc. to DIN 7-04
- 2 Cable,
- securely installed: 55 mm
- flexibly installed: 70 mm

Rotary Measuring Technology

Absolute encoders, Multiturn, optional with incremental track



Multiturn Type 5862 (Shaft) / 5882 (Hollow shaft) SSI or RS 485, programmable

Order code hollow shaft version:

8.5882.XXXX.XXXX

Type	
Flange	<p>1 = Flange type 1 with through shaft and torque support slot</p> <p>3 = Flange type 3 with through shaft and stator coupling*</p> <p>*Shaft clamping on other side on request</p>
Hollow shaft	<p>6 = Hollow shaft ø 10 mm</p> <p>8 = Hollow shaft ø 12 mm</p>
Interface	<p>2 = SSI 5 ... 30 V DC with 4 status outputs</p> <p>3 = RS 485, half-duplex 5 ... 30 V DC internal termination</p> <p>5 = SSI, 5 ... 30 V DC with incremental track 2048 ppr (A, B, \bar{A}, \bar{B})</p> <p>7 = RS45, half-duplex 5 ... 30 V DC external termination</p> <p>9 = SSI 4.75 ... 30 V DC. with 2 status outputs and 2 sensor outputs for monitoring the supply voltage on the encoder.</p>
Type of connection	<p>1 = Radial cable (1 m PVC-cable)</p> <p>2 = 12 pin plug radial</p> <p>5 = Radial cable (5 m PVC-Cable)</p>

SSI-Interface *

2001 = 4096 x 4096 (24-Bit), Binary

2002 = 8192 x 4096 (25-Bit), Binary

2003 = 4096 x 4096 (24-Bit), Gray

2004 = 8192 x 4096 (25-Bit), Gray

RS 485-Interface half-duplex

3001 = ESC protocol, max. 38400 Baud

*This factory set (default) resolution can be re-programmed by using the Ezturn® software.

Accessories:
 Corresponding mating connector to connection type 2
 Order code 8.0000.5012.0000

- Programming kit Ezturn® includes
- Interface converter
 - Connection cable with the interface converter encoder – PC
 - 90-250 V AC power supply
 - CD-ROM with Ezturn® software



Order code 8.0010.9000.0004

Preferred types are indicated in bold

Patented Intelligent-Sensing-Technology (IST)®

An innovative principle of operation based on a non-contact electronic multiturn stage overcomes system disadvantages previously associated with encoders that had mechanical gears or with traditional electronic gear technology.

- Advantages:**
- High operational reliability
 - Logic filter and innovative principle of operation compensate for high EMC interference
 - Free from wear

Absolute Encoders