

Absolute Encoders

| | | | |
|-------------------|------------------------|--|------------|
| Singleturn | Sendix absolute | 7053 (Shaft) with ATEX approval | SSI |
|-------------------|------------------------|--|------------|



The Sendix 7053 absolute singleturn encoders offer Ex protection in a compact 70 millimetre housing.

These shock and vibration-resistant encoders operate flexibly with a resolution of up to 17 bits; they are also available as multiturn encoders.



Safety-Lock™



High rotational speed



High IP value



High shaft load capacity



Shock / vibration resistant



Magnetic field proof



Short-circuit proof



Reverse polarity protection



Ex approval

Safe

- “Flameproof-enclosure” version: approved for zone 1, 2 and 21, 22
- Zone 1, 2 and 21, 22:
Ex II 2G Ex d IIC T6 and Ex II 2D Ex tD A21 IP6X T85°C
- Can be operated in marine environments – housing and flange out of seawater-resistant aluminium
- Remains sealed even in harsh everyday use and ensures highest safety against field breakdowns. IP 67 protection

Compact

- Can be used even when space is tight
- Installation depth only 145 mm, diameter 70 mm
- Compact cable outlet

Order code

8.7053 . 1 X 2 X . XX 2 1 . XXXX

Shaft version

1 Flange

1 = Clamping-synchronous flange, ø 70, IP 67

2 Shaft (ø x L)

1 = Shaft 12 mm x 25 mm
with keyway for 4 x 4 mm key
2 = Shaft 10 mm x 20 mm

3 Output circuit / Supply voltage

2 = SSI, 10 ... 30 V DC

4 Type of connection

1 = Cable axial (2m PVC cable)
A = Cable axial (length > 2 m)
(preferred lengths, see 9, 0100 = 10 m)

5 Code

B = SSI, Binary
G = SSI, Gray

6 Resolution ¹⁾

A = 10 bit ST
1 = 11 bit ST
2 = 12 bit ST
3 = 13 bit ST
4 = 14 bit ST
7 = 17 bit ST

7 Inputs/Outputs ¹⁾

2 = SET, DIR input
additional status output

8 Options

1 = no option

9 Cable length in dm

0050 = 5 m
0100 = 10 m
0150 = 15 m

Preferred types are underlined

1) Resolution, preset value and counting direction factory-programmable

Absolute Encoders

| | | | |
|-------------------|------------------------|--|------------|
| Singleturn | Sendix absolute | 7053 (Shaft) with ATEX approval | SSI |
|-------------------|------------------------|--|------------|

| Explosion protection | |
|--|--|
| EC type-examination certificate | PTB09 ATEX 1106 X |
| Category (gas) | II 2G Ex d IIC T6 |
| Category (dust) | II 2D Ex tD A21 IP6X T85°C |
| Directive 94/9 EC | EN 60079-0; DIN EN 60079-1 EN 61241-0; DIN EN 61241-1 |

| Mechanical characteristics | |
|--|---|
| Max. speed | 6 000 min ⁻¹ continuous |
| Starting torque | < 0,05 Nm |
| Weight moment of inertia | 4,0 x 10 ⁻⁶ kgm ² |
| Shaft load capacity | radial 80 N axial 40 N |
| Weight | approx. 0,6 kg |
| Protection acc. to EN 60 529 | IP 67 |
| Working temperature range | -40°C ... +60°C |
| Materials | shaft stainless steel flange seawater-resistant Al, type AISiMgMn (EN AW-6082) (optional: stainless steel) housing seawater-resistant Al, type AISiMgMn (EN AW-6082) (optional: stainless steel) cable PVC |
| Shock resistance acc. to DIN-IEC 68-2-27 | >2500 m/s ² , 6 ms |
| Vibration resistance acc. to DIN-IEC 68-2-6 | >100 m/s ² , 55 ... 2000 Hz |

| General electrical characteristics | |
|--|--|
| Supply voltage | 10 ... 30 V DC |
| Current consumption (w/o output load) | 24 V DC max. 25 mA |
| Reverse polarity protection for power supply (Ub) | yes |
| CE compliant acc. to | EN 61000-6-2, EN 61000-6-4 and EN 61000-6-3 |
| RoHS compliant acc. to | EU guideline 2002/95/EG |

| SSI interface | |
|--|---|
| Output driver | RS 485 Transceiver type |
| Permissible load/channel | max. 20 mA |
| Signal level | high typ 3,8 V low for I _{Last} = 20 mA typ 1,3 V |
| Short-circuit proof outputs | yes ¹⁾ |
| Singleturn resolution | 10 ... 14 bit and 17 bit ²⁾ |
| Number of revolutions | 4096 (12 bit) |
| Code | Binär or Gray |
| SSI clock rate | < 14 bit: 50 kHz ... 2 MHz |
| Monoflop time | < 15 µs ²⁾ |
| Note: if clock starts cycling within monoflop time a second data transfer starts with the same data. If clock starts cycling after monoflop time, the data transfer starts with updated values. The update rate depends on clock speed, data length and monoflop time. | |
| Time jitter | up to 14 bit < 1 µ for 15 ... 17 bit < 4 µs |
| Status and Parity bit | upon request |

1) Short-circuit with 0V or output, only one channel at a time, supply voltage correctly applied
2) Other options upon request

| SET input | |
|---|---|
| Input | high active |
| Input type | Comparator |
| Signal level | high min. 60 % of V+ max: V+ low max. 25 % of V+ (V+ = supply voltage) |
| Input current | < 0,5 mA |
| Min. pulse duration (SET) | 10 ms |
| Timeout after SET signal | 14 ms |
| Response time (DIR input) | 1 ms |
| The encoder can be set to zero at any position by means of a High signal on the SET input. Other preset values can be factory-programmed. The SET input has a signal delay time of approximately 1 ms. Once the SET function has been triggered, the encoder requires an internal processing time of approximately 15 ms before the new position data can be read. | |

| DIR input | |
|---|--|
| A High signal switches the direction of rotation from the default CW to CCW. The reverse function can also be factory-programmed. | |
| If DIR is reversed when the device is already switched on, this will be interpreted as an error. The status output switches to Low. | |

| Status output | |
|--|--|
| Output driver | Open collector internal pull-up resistor 22 kohm |
| Permissible load | 20 mA |
| Signal level | high +V low < 1 V |
| Active at | low |
| The status output serves to display various alarm or error messages. The status output is high (Open Collector with internal pull-up 22k) in normal operation. | |

| Power-on delay | |
|---|--|
| After Power-On, the device requires a time of approximately 150 ms before valid data can be read. | |

Absolute Encoders

| | | | | | | | | | | | | |
|-------------------|------------------------|--|--|--|--|--|------------|--|--|--|--|--|
| Singleturn | Sendix absolute | 7053 (Shaft) with ATEX approval | | | | | SSI | | | | | |
|-------------------|------------------------|--|--|--|--|--|------------|--|--|--|--|--|

Terminal assignment

for output circuit 1 or 2

| Signal | GND | +V | +C | -C | +D | -D | SET | DIR | Stat | PE | PE |
|---------------|-----|----|----|----|----|----|-----|-----|------|--------------|--------|
| Cable marking | 1 | 2 | 3 | 4 | 5 | 6 | 7 | 8 | 9 | yellow/green | Shield |

+V: Encoder power supply +V DC

GND: Encoder Ground GND (0V)

+C, -C: Clock signal

+D, -D: Data signal

SET: Set input. The current position becomes defined as position zero.

DIR: Direction input. If this input is active, output values are decreasing when shaft is turned clockwise

Stat: Status output

PE: Protective earth

Dimensions

Shaft type 1

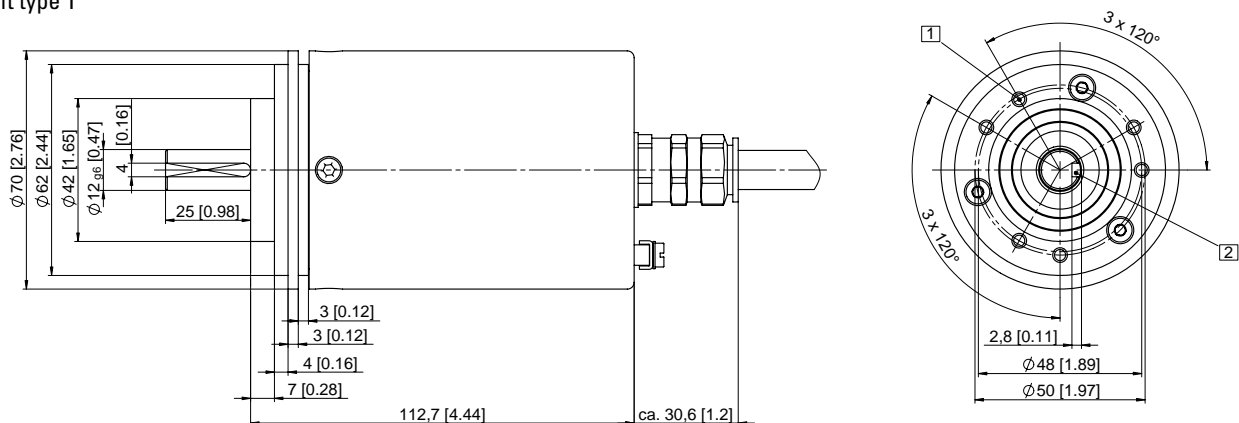

Shaft type 2

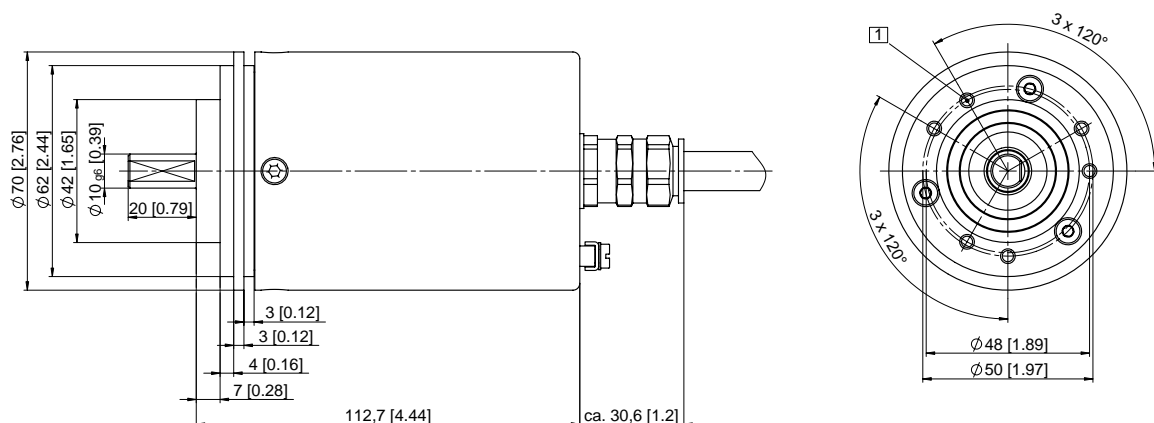

1 6 x M4, 10 [0,39] deep

2 Keyway for DIN6885-A-4x4x25 key