

Couplings



- Bellow type couplings are recommended as an inexpensive type of coupling
- They are also suitable to compensate larger angular displacements
- Spring washer type couplings for high speed applications
- Easy to mount, two parts

Description and applications

Manufacturing and installation tolerances as well as the effects of temperature cause alignment errors between shafts in drive engineering which can sometimes lead to extreme overload on the bearings. This may result in increased wear of the bearings and may lead to premature failure of the encoder. By using couplings, these

alignment errors can be compensated, thereby reducing the load on the bearings to a minimum.

A distinction should be made between three different kinds of alignment error: radial, angular and axial displacement.

Whilst with torsion-free but bendable shaft couplings, axial shaft displacements

produce only static forces in the coupling, radial and angular displacements produce alternating stresses, restoring forces and moments which may have an impact on adjoining components (shaft bearings). Depending on the type of coupling, particular attention should be paid to radial shaft displacement which should be kept to a minimum.

Areas of application:

Metal bellows-type couplings (.1101 and 1201) are recommended as an inexpensive type of coupling. They are also suitable for compensating larger angle displacements.

Spring washer-type couplings (.1300 and .1401) are used mainly in those cases where high speeds and smaller angular displacements are involved. For applications where

electrical insulation between rotary encoder and drive is required, the electrically insulating spring washer-type coupling should be used.

Installation instructions:

1. Check shaft for displacement; See technical data for details
2. Align and adjust coupling on shafts.

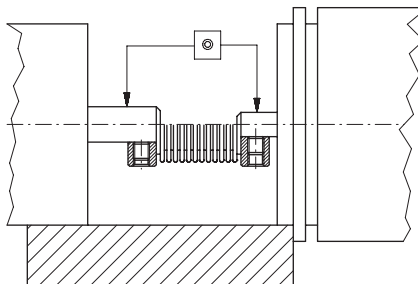

3. Tighten locking screws carefully. Avoid overtightening.
4. During installation protect the coupling from damage and from overbending.

Technical data

Type		8.0000.1101.XXXX	8.0000.1201.XXXX	8.0000.1301.XXXX	8.0000.1401.XXXX	1501.XXXX
Max. speed	min ⁻¹	12000	12000	12000	12000	12000
Max. torque	Ncm	150	50	80	60	200
Max. radial displacement	mm	± 0,2	± 0,2	± 0,4	± 0,3	± 0,2
Max. angular displacement	Grad	± 1,5	± 1,5	± 3	± 2,5	± 1,5
Max. axial displacement	mm	± 0,7	± 0,5	± 0,4	± 0,4	± 0,6
Torsion spring parameter	Ncm/Grad	700	210	265	55	1300
Moment of inertia	gcm ²	5,5	1,2	19	35	18
Weight approx.	g	14	6	16	30	24
Material: Flange		Al	Al	Al cu Mg Pb	diecast Zinc	Al
Bellow or spring washer/casing		stainless steel	stainless steel	Cu Sn 6 Vern.	PA 6,6 20% gf	stainless steel
Diameter d/d1 from ... to	mm	3...12	3...9	3...8	4...16	3...16
Max. tightening torque of locking screws	Ncm	150	70	80	80	180
Standard bore diameter [d ₁ /d ₂]		12/12	8/6	6/6	12/12	15/12
		12/10	6/6	6/4	12/10	14/12
		10/10	6/4		10/10	14/10
		6/6	4/4		10/6	06/14
			10/8		6/6	
					3/8"/10	
					3/8"/6	
					1/4"/10	
					1/4"/6	

Couplings

Bellows-type coupling

Order code 8.0000.1501.XXXX

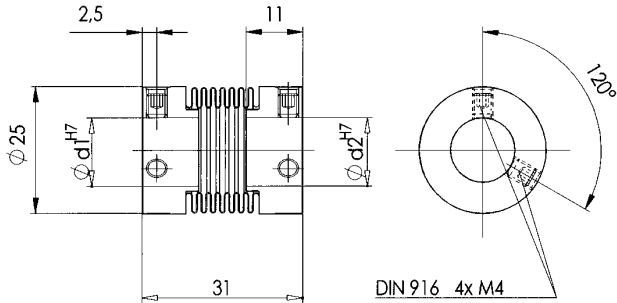

Spring washer coupling

Order code 8.0000.1300.XXXX

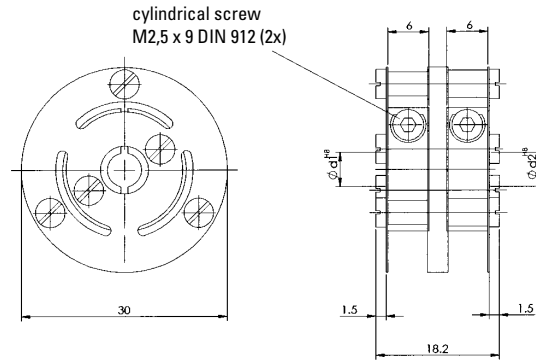

Bellows-type coupling

Order code 8.0000.1101.XXXX

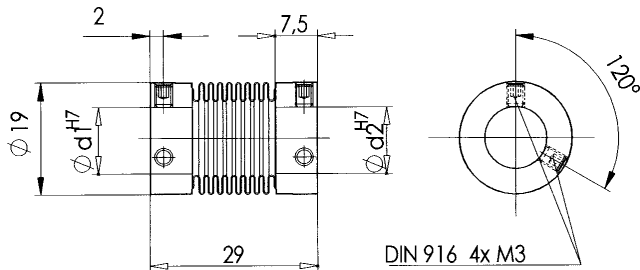

Spring washer coupling

Order code 8.0000.1401.XXXX

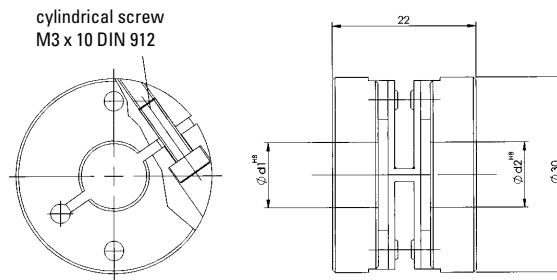

Bellows-type coupling

Order code 8.0000.1201.XXXX

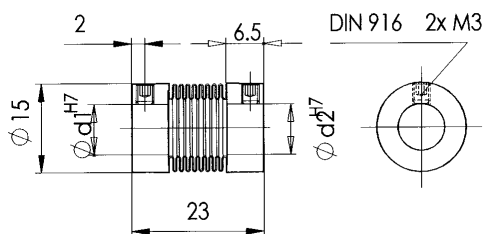

Order code:

8.0000.1X01.XXXX

Description of the Order Code

Type of coupling

- 1 Bellows-type ø 19 mm
- 2 Bellows-type ø 15 mm
- 3 Spring washer type
- 4 Spring washer type*
- 5 Bellows-type ø 25 mm

Bore diameter d_2
(see table)

Bore diameter d_1
(see table)

Example: a) $d_1 = 10$ mm and $d_2 = 12$ mm
=> XXXX.XXXX.1012)

Note: for the bore diameter
 $d_1 = 3/8"$ please enter Code A1
 $d_1 = 1/4"$ please enter Code A2

Example: b) Coupling type 1401 with
 $d_2 = 10$ mm and $d_1 = 3/8"$:
Order code = 1401.A110