

## Micro Timers – HK 46 / HK 47

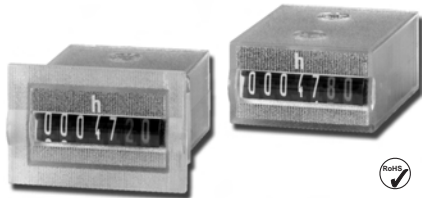

- 6- or 7-digit micro hour meters; displays 1/100 h
- Low cost
- High shock resistance
- Low power consumption; suitable for battery operation
- Small dimensions
- Magnified large figures
- Flush mount with integrated spring clip (snap in) (HK46.20 / HK47.20)
- PCB-mount (HK46.80 / HK 47.80)
- Solderable and wash proof (HK 47.80)
- Protection to IP 66
- Long service life

### Applications:

time registration, maintenance intervals for measuring instruments (respiration units, oxygen, dialysis), UV-lamps, machines panel indicators in vehicles ...

### Technical data:

Drive:	Quartz controlled impulse drive
Impulse duration:	32 ms; every 36 s = 0.01 h (Power on times < 36 s are not counted)
Electrical connection:	HK 46.20/HK 47.20: Flying leads AWG 22, approx. 150 mm [5.906"] long (red +, black -) HK 46.80/HK 47.80: solder pins $\varnothing$ 0.64 mm [0.025"]
Display:	9999.99 h resp. 99999.99 h
Figures:	white on black 1/10, 1/100 decimal red on black
Supply voltage:	4.5 ... 35 V DC
Residual ripple:	< 1 %
Current consumption:	< 1.5 mA (average)
Power consumption:	at $U_B = 5$ V DC typ. 82 mW at $U_B = 12$ V DC typ. 135 mW at $U_B = 24$ V DC typ. 135 mW max. 170 mW (count impulse every 36 s with an impulse duration of 32 ms)
Accuracy:	22.5 ppm at 25 °C [[77 °F]

Height of figures:	HK 47: 4 x 1.25 mm [0.158 x 0.049"] HK 46: 4 x 1.7 mm [0.158 x 0.067"] magnified
Reset:	no reset
Ambient temperature:	-10 ... +60 °C [14 .. 140 °F] non condensing
Storage temperature:	-20 ... +70 °C [-4 ... 158 °F]
Mounting position:	any
Solderable and wash proof versions:	HK 46.80/HK 47.80
Soldering temperature:	265 °C, max. 3 sec.
Protection according to EN 60529:	IP 66 for HK 46.80/HK 47.80 IP 66 (only front) for HK 46.20/HK 47.20
EMC:	Immunity to interference: EN55011 class B Emitted interference EN61000-6-2
Housing:	PC transparent; HK 47.80
Weight:	13 ... 15 g [0.459 ... 0.529 oz]
Options for:	
HK 4X.20, 4X.80:	flat pin 0.8 x 2.8 mm [0.032 x 0.11"] and push-on connectors
HK 46.20/HK 47.20:	solder pins $\varnothing$ 0.64 mm [0.025"]
HK48.80/HK47.80:	cable AWG22, 150 mm long [5.9"]

### Dimensions:

HK 46.20/HK 47.20

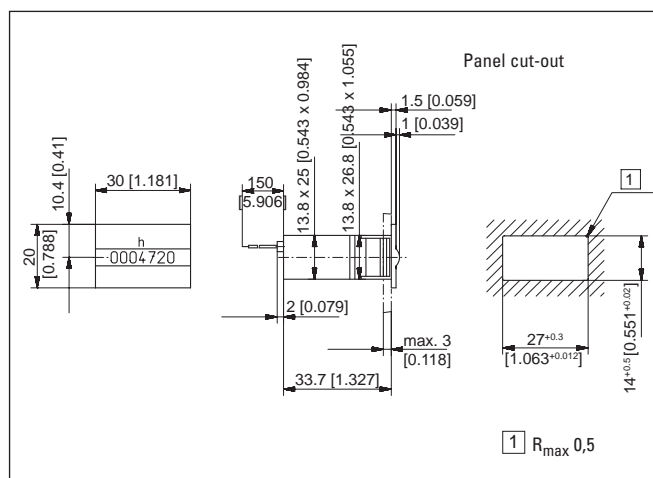

HK 46.80/HK 47.80

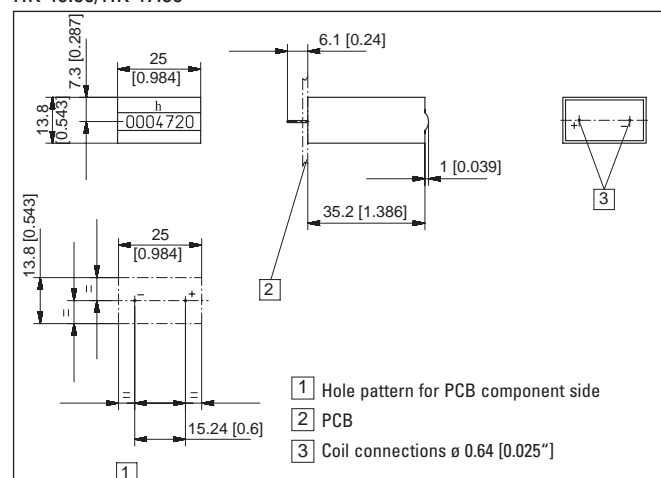

### Order code:

	HK 46.20	HK 47.20
	Art. no.	Art. no.
4.5 ... 35 V DC	3.050.200.383	3.060.200.383 *

\*standard stock model

	HK 46.80	HK 47.80
	Art. no.	Art. no.
4.5 ... 35 V DC	3.050.800.383	3.060.800.383