

Rotary Measuring Technology

Rotary magnetic measurement system

Rotary magnetic measurement system RI20/ LI20

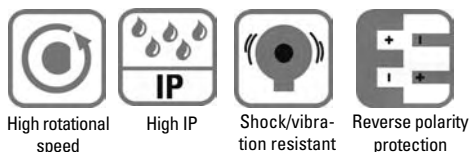

Robust

- **Increased ability to withstand vibrations and rough installation**
Eliminates machine downtime and repairs
High shock and vibration resistance, thanks to non-contact technology.
- **Stays sealed even when subjected to harsh everyday use. Offers security against failures in the field.**
Solid housing with up to IP 67 protection.



Compact

- **Installation depth only 16 mm, width of magnetic ring 10 mm**
- **Large hollow shaft up to 30 mm**
Can be used even where space is very tight

Simple installation

- **Fast start-up of the measuring system**
Easy fixing of the magnetic ring and the sensor head
- **Easy mounting with large tolerances possible**
Distance of sensor head to magnetic ring from 0.1 to 1.0 mm
- **Tolerates lateral misalignment + 1 mm**
- **Warning signal when magnetic field is too weak (LED)**

Incremental Encoders

Technical data magnetic sensor LIMES LI20:

Output circuit:	Push-Pull	RS422
Supply voltage:	4,8 ... 30 V DC	4,8 ... 26 V DC
Load/channel, max. cable length:	±20 mA, max. 30 m	120 Ohm, RS422 standard
Current consumption (without load):	typ. 25 mA, max. 60 mA	
Short circuit proof outputs¹⁾:	yes	yes ²⁾
Min. Pulse interval:	1 μs (edge interval) corresp. to 4 μs/period (see signal figures below)	
Output signal:	A, \bar{A} , B, \bar{B} , I, \bar{I}	
Reference signal:	Index periodical	
Accuracy:		
System Accuracy:	typ. ±0,3° with shaft tolerance g6	
Repeat accuracy:	±1 increment	
Admissible Alignment tolerance	see draft „Mounting tolerances“	
Gap sensor / magnetic ring:	0.1 ... 1.0 mm (recommended 0,4 mm)	
Offset:	max. ±1 mm	
Tilting:	max. 3°	
Torsion:	max. 3°	
Environmental conditions:		
Working temperature:	-20 ... +80 °C	
Shock resistance:	30 g/10 ... 2000 Hz	
Protection class:	IP 67 according to DIN 60 529 (housing)	
Humidity:	100 %, condensation possible	
Housing:	Zinc die-cast	
General data:		
Cable:	2 m, PUR 8 x 0,14 mm ² , shielded, may be used in trailing cable installations	
Status-LED:	Green: Pulse-index; Red: Error, revs too high or magnetic field too weak (for 8.LI20.XXXX.X020 and 8.LI20.XXXX.X050)	
CE-compliant according to:	EN 61 000-6-1, EN 61 000-6-4, EN 61 000-6-3 EN 61 000-4-8 (magnetic field)	
RoHS compliant acc. to EU guideline 2002/95/EG		

Technical data magnetic ring RI20:

Pole gap:	2 mm from pole to pole
Temperature ranges:	
Working temperature	-20 ... +80 °C
Storage temperature	-20 ... +80 °C
Mounting:	Screwed on shaft
System accuracy:	typ. ±0,3° (at 25 °C, Sensor/Magnetic ring Distance 0,5 mm and Drive shaft tolerance g6

Signal figures

with rotation of the magnetic ring in the CW-direction (see draft „Mounting tolerances“)

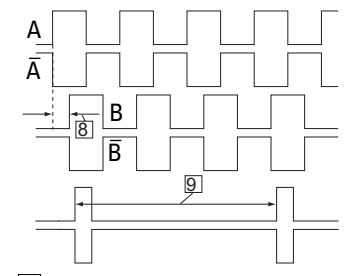

- 9] periodic index signal (every 2mm) the logical assignment A, B and I-signal can change
- 8] Min. Pulse interval: pay attention to the instructions in the technical data

¹⁾ With supply voltage correctly applied
²⁾ A max. of one channel only may be short-circuited: (when UB=5 V, a short circuit to another channel, 0 V, or +UB is permissible.) (when UB=5-30 V, a short circuit to another channel or to 0 V is permissible.)

New

Rotary Measuring Technology

Rotary magnetic measurement system



Rotary magnetic measurement system RI20/ LI20

Magnetic ring 8.RI20.031.XXXX.111, \varnothing 31 mm

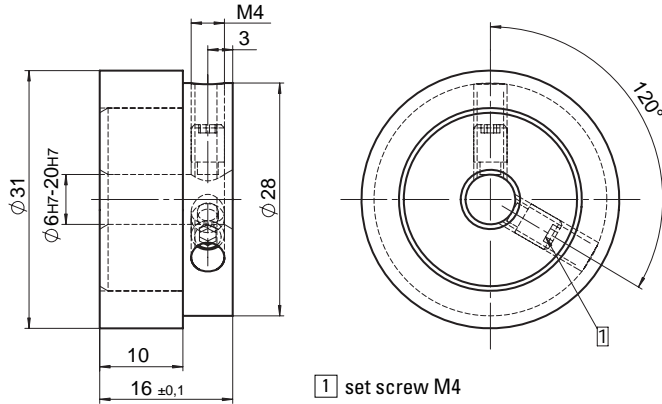

1 set screw M4

Magnetic ring 8.RI20.041.XXXX.111, \varnothing 41,2 mm

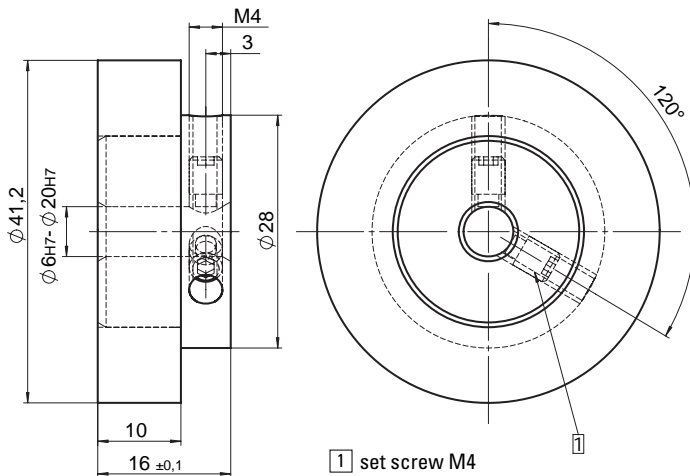

1 set screw M4

Magnetic ring 8.RI20.045.XXXX.111, \varnothing 45 mm

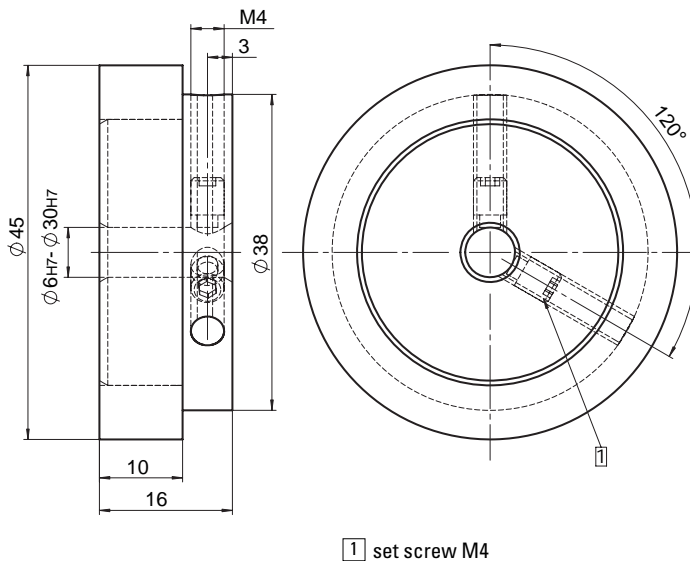

1 set screw M4

Recommended tolerance of the drive shaft diameter: g6

Magnetic sensor LIMES LI20:

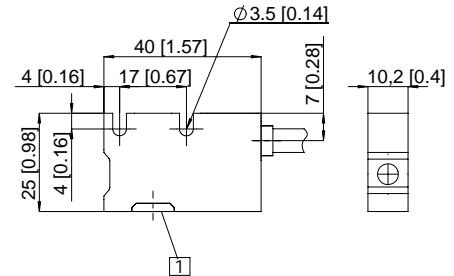

1 active measuring area

Pin assignment:

Signal	Wire colour
0 V, GND	white
U_B	brown
A	green
\bar{A}	yellow
B	gray
\bar{B}	pink
I	blue
\bar{I}	red

Shield is on the housing

Permissible mounting tolerances:

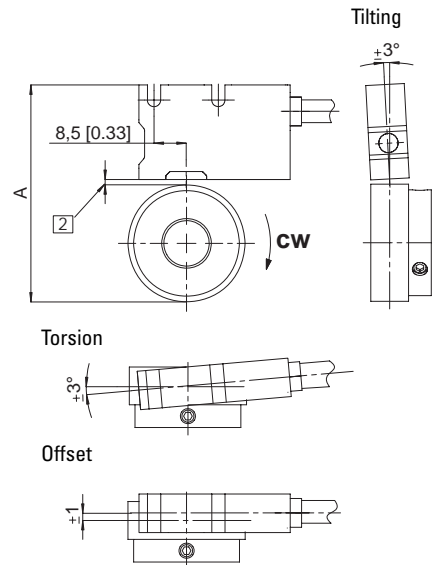

2 Distance Sensor / Magnetic ring:
0.1... 1.0 mm (0.4 mm recommended)

Magnetic ring	A
8.RI20.031.XXXX.111	56,4 ¹⁾
8.RI20.041.XXXX.111	66,6 ¹⁾
8.RI20.045.XXXX.111	70,4 ¹⁾

¹⁾ With Distance Sensor /
Magnetic ring = 0,4 mm

Rotary Measuring Technology

Rotary magnetic measurement system

Kübler

New

Rotary magnetic measurement system RI20/ LI20

Order code magnetic sensor **LIMES LI20:**

8.LI20.11X1.2XXX

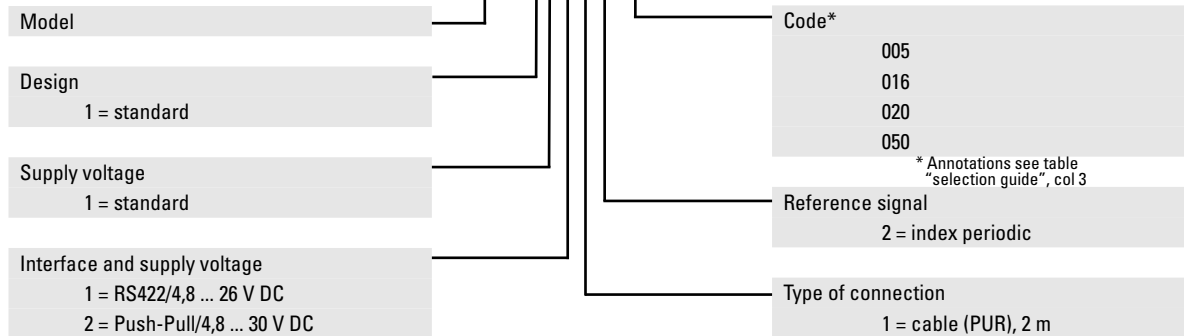

Incremental Encoders

Order code magnetic ring **RI20:**

Order code/type	Outer-diameter	Bore diameter
8.RI20.031.0800.111	31 mm	8 mm
8.RI20.031.1000.111	31 mm	10 mm
8.RI20.031.1200.111	31 mm	12 mm
8.RI20.031.1500.111	31 mm	15 mm
8.RI20.031.1587.111	31 mm	15,875 mm (5/8")
8.RI20.031.2000.111	31 mm	20 mm
8.RI20.041.0800.111	41,2 mm	8 mm
8.RI20.041.1500.111	41,2 mm	15 mm
8.RI20.045.0800.111	45 mm	8 mm
8.RI20.045.0925.111	45 mm	9,525 mm (3/8")
8.RI20.045.1200.111	45 mm	12 mm
8.RI20.045.1500.111	45 mm	15 mm
8.RI20.045.1800.111	45 mm	18 mm
8.RI20.045.2500.111	45 mm	25 mm
8.RI20.045.2540.111	45 mm	25,4 mm (1")
8.RI20.045.3000.111	45 mm	30 mm

Selection guide:

LIMES LI20/magnetic ring RI20

Pulses/ppr	Order code for Magnetic ring RI20	Order code for magnetic sensor Limes LI20	max. rpm
250	8.RI20.031.XXXX.111	8.LI20.11X1.2005	12000
1000	8.RI20.031.XXXX.111	8.LI20.11X1.2020	2400
2500	8.RI20.031.XXXX.111	8.LI20.11X1.2050	3900
1024	8.RI20.041.XXXX.111	8.LI20.11X1.2016	7000
360	8.RI20.045.XXXX.111	8.LI20.11X1.2005	12000
3600	8.RI20.045.XXXX.111	8.LI20.11X1.2050	2700

*At the listed rotational speed the min. pulse interval is 1 µs, this corresponds to 250 kHz. For the max. rotational speed range a counter with a count input frequency of not less than 250 kHz. should be provided.

Stock types		
Magnetic sensor LI20:	Magnetic ring RI20:	
8.LI20.1111.2005	8.RI20.031.0800.111	8.RI20.045.1500.111
8.LI20.1111.2016	8.RI20.031.1000.111	8.RI20.045.2500.111
8.LI20.1111.2020	8.RI20.031.1200.111	
8.LI20.1111.2050	8.RI20.031.1587.111	
8.LI20.1121.2005	8.RI20.041.0800.111	
8.LI20.1121.2016	8.RI20.045.0800.111	
8.LI20.1121.2020	8.RI20.045.0925.111	
8.LI20.1121.2050	8.RI20.045.1200.111	

Display Type 572 for **LIMES LI20:**



Counter series for demanding applications, with two individually scalable encoder inputs. HTL or TTL in each case A, \bar{A} , B, \bar{B} for count frequencies up to 1 MHz per channel. Operating modes can be selected for position or event counter, total counter, difference counter, cut-to-length display, diameter calculator, batch counter and more.

- 2 separate freely scalable count inputs - HTL or TTL; also with inverted inputs
- Max. input frequency 1 MHz/ channel
- 4 freely programmable fast solid-state outputs, each with 350 mA output current
- Step or tracking preset
- AC and DC supply voltage
- Can be used as a counter or position display with limit values
- Monitoring function, where 2 values are monitored or calculated with respect to each other
- 4 fast programmable inputs with various functions such as reset, gate, display memory, reference input or switching between the display values.
- Optional scalable analogue output 0/4 ... 20 mA, +/-10 V or 0 ... 10 V

- 2 auxiliary power supplies for sensors: 5.2 V DC and 24 V DC
- Standard interface RS 232

Order code specification:

Position display, 6 digits, with 4 fast switch outputs and serial interface:

6.572.0118.D05

Position display, 6 digits, with 4 fast switch outputs and serial interface and scalable analogue output:

6.572.0118.D95

Position display, 8 digits, with 4 fast switch outputs and serial interface:

6.572.0118.D05

Position display, 8 digits, with 4 fast switch outputs and serial interface and scalable analogue output:

6.572.0118.D95