

# Linear Measuring Technology

## Spring encoder arm



### Spring encoder arm



Temperature range



Shock/vibration resistant

#### Robust

- **Pressure**  
Max. 40 N, adjustable spring pressure available in any position



#### Versatile

- **Can be installed in any mounting position**  
9 setting positions in 40° steps
- **Base plate**  
Variable in 4 directions

#### Reliable

- **Temperature range**  
-40 °C ... 120 °C

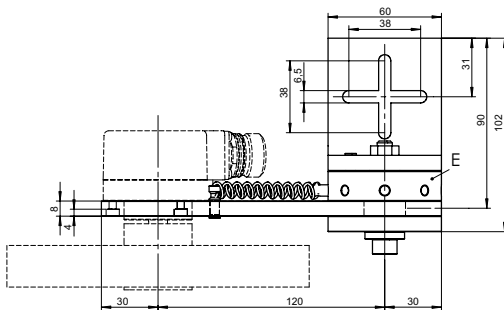
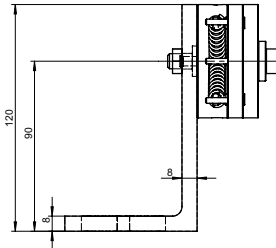
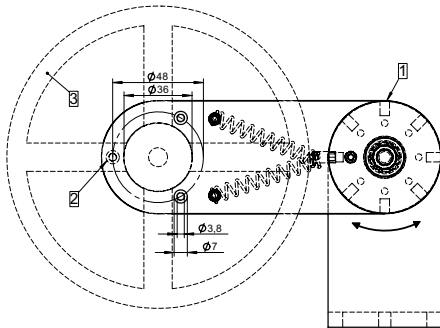

- 1 Setting with a size 0 or 1 screwdriver
- 2 3 pcs. screws M3 x 8 DIN 912 included
- 3 Measuring wheel

#### Technical data:

Pressure for each notch:    appr. 20 N (first notch between 0 and appr. 20 N)  
Temperature:                    -40 °C ... + 120 °C

Order code: 8.0010.7000.0010

