

MODEL APSIS - Octal Plug-in Accessory Power Supply With 20 mA Current Sources

PROVIDES...

- 24 VDC UNREGULATED "HELPER" SUPPLY FOR LOAD SHARING WITH OTHER 24 VOLT SYSTEMS WITH UNUSUAL SENSOR AND ACCESSORY LOADS OR...
- "STAND-ALONE" APPLICATIONS FOR POWERING +24 VDC SENSORS AND ACCESSORIES OR...
- TWO 20 mA CURRENT SOURCES, EACH CAPABLE OF SUPPLYING 20 mA OF CURRENT FOR SERIAL COMMUNICATION LOOPS AND POWERING UP TO 16 UNITS PER LOOP.



DESCRIPTION

The Model APSIS is a convenient plug-in unregulated +24 VDC power supply designed to "load share" when connected in parallel with other +24 VDC unregulated systems with unusual power requirements due to sensor or accessory loading (see Fig.1). It can also be used as a general purpose stand-alone supply to power +24 VDC control circuits, sensors and accessories (see Fig.2). In addition, two 20 mA Current Source outputs are available, each capable of powering up to 16 Serial Communications units (see Fig.3). The APSIS is available in 115 and 230 VAC ±10%, 50/60 Hz. primary supply (see Ordering Information). Operating temperature range is -20°C to +50°C.

SPECIFICATIONS

1. **POWER SOURCE:** 2 versions, 115 VAC or 230 VAC ±10%, 50/60 Hz., 11 VA max. (see Ordering Information).
2. **POWER OUTPUT:** +24 VDC unregulated @ 200 mA max. current*, Ripple = 1.5 V P-P max.
3. **OUTPUT:** Two 20 mA current sources, each capable of supplying 20 mA of current for serial communication loops and powering up to 16 units per loop.
4. **OPERATING TEMPERATURE:** -20°C to +50°C (-4°F to +122°F)

* Maximum available output current derates to 175 mA with 1 source active and 150 mA max. with both sources active.

TYPICAL LOAD SHARING CONNECTION DIAGRAM

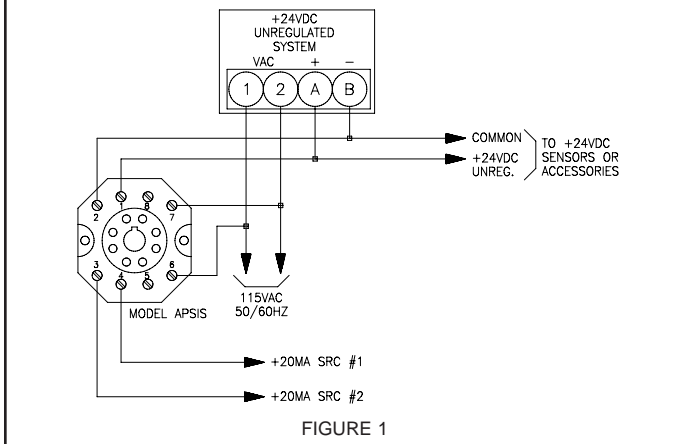

DIMENSIONS In inches (mm)

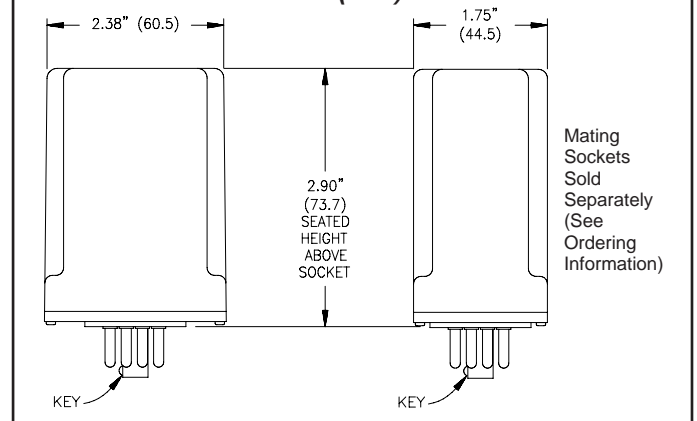

TEMPERATURE MONITORING SYSTEM

A temperature monitoring process requires both remote and control room indicators and datalogging capabilities. An RTD (Resistance Temperature Detector) to 4 to 20 mA Transmitter, provides a proportional 4 to 20 mA output from the RTD input. Two Red Lion Controls "Loop Powered Process Indicators" (Model LPPI) are installed in series in the "Loop" and scaled to provide Local and Remote temperature displays. A Datalogger is also placed in the "Loop" to provide a hard-copy of process temperatures. Each device in the "Loop" has an associated "voltage drop" as follows: RTD Transmitter = 9 VDC drop; LPPI = 3 VDC x 2 units = 6 VDC drop; Datalogger = 5 VDC drop. The total voltage drops in the "Loop" = 20 VDC. Therefore, RLC's Model APSIS, with its +24 VDC Supply, is used to power this process "Loop".

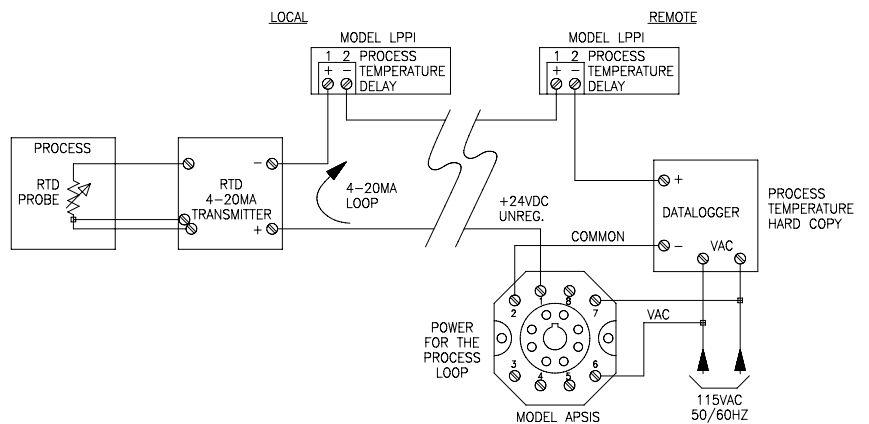

PROCESS MONITORING SYSTEM

8 Apollo Thermocouples (APLTC) and 8 GEMINI's, all with isolated 20 mA Current Loop Serial Communications, monitor and control processes within a plant. All units, which are located in different areas of the plant, are tied together in series in two "Loops" (one Transmit Tx, the other Receive Rx) and are connected to a Central Computer located in another area of the plant. Since there are more than 7, and no more than 16 units in the "Loop", the APSIS +20 mA Current Source Outputs are used to power each "Loop". (Both Apollo Thermocouple and Gemini units can power up to 7 units in a "Loop" when using their internal 20 mA sources. However, their sources may not be tied together to power more than 7 units.) Each unit is assigned a different address number and the same Baud rate (see appropriate APLTC or Gemini data sheet). An application program is written which allows the Central Computer to send and retrieve data from any APLTC or Gemini.

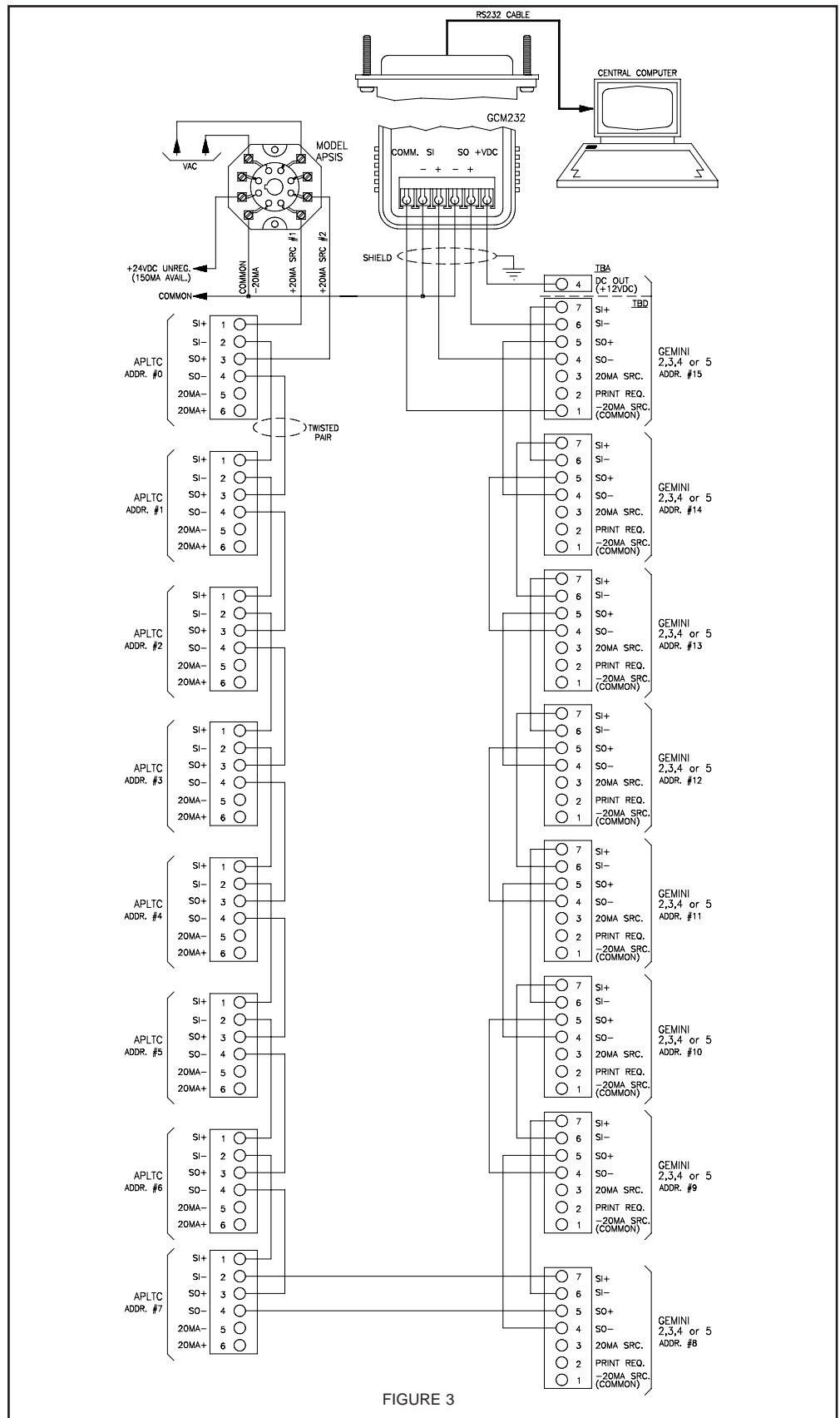
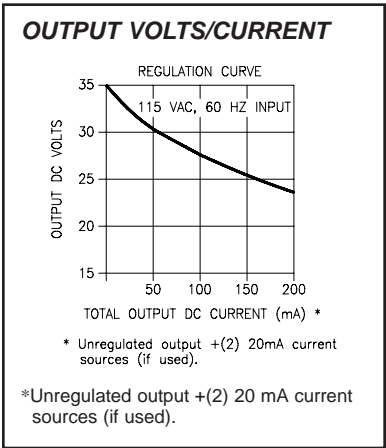

FIGURE 3

ORDERING INFORMATION

MODEL NO.	DESCRIPTION	PART NUMBERS FOR AVAILABLE SUPPLY VOLTAGES	
		230 VAC	115 VAC
APSYS	Accessory Power Supply- Current Source	APSYS010	APSYS000
—	Base Mount, 8-Pin Octal Socket	SKT10000	
—	Din Rail Mount, 8-Pin Octal Socket	SKTDIN00	