

## MODEL IRMA - INTELLIGENT RTD MODULE WITH ANALOG OUTPUT



- USER PROGRAMMABLE INPUT (RTD  $\alpha=0.00385$  (DIN 43760),  $\alpha=0.00392$ , or resistance)
- 12 to 42 VDC LOOP POWERED (4 to 20 mA Output)
- MICROPROCESSOR CONTROLLED
- SIMPLE ADJUSTABLE RANGE SETTING (Using Input Signal)
- RTD BREAK DETECTION
- MOUNTS ON "T" AND "G" STYLE DIN RAILS
- 2-WAY ELECTRICAL ISOLATION (INPUT/OUTPUT & POWER)
- HIGH-DENSITY PACKAGING (22.5 mm wide)
- WIDE OPERATING TEMPERATURE RANGE



### DESCRIPTION

The IRMA accepts a 2, 3, or 4 wire RTD or resistance input and converts it into a 4 to 20 mA current output. The 4 to 20 mA output is linearly proportional to the temperature or the resistance input. This output is ideal for interfacing to indicators, chart recorders, controllers, or other instrumentation equipment.

The IRMA is loop-powered which means that the same two wires are carrying both the power and the output signal. The unit controls the output current draw from 4 to 20 mA in direct proportion to the input while consuming less than 4 mA for operation. The conversion to a current output signal makes the IRMA less susceptible to noise interference and allows accurate transmission over long distances. Two-Way isolation allows the use of grounded RTD's which can provide additional noise reduction benefits.

The IRMA uses an eight position DIP switch to accomplish the input sensor configuration, range selection, and unit calibration. A simple range setting technique (Field Calibration) is used so the actual input signal adjusts the output current for scaling. This technique eliminates the need for potentiometers which are vulnerable to changes due to vibration.

The unit is equipped with a universal mounting foot for attachment to standard DIN style mounting rails, including top hat rail (T) according to EN 50 022 - 35 X 7.5 and 35 X 15, and G profile according to EN 50 035 - G 32.

### SAFETY SUMMARY

All safety related regulations, local codes and instructions that appear in the manual or on equipment must be observed to ensure personal safety and to prevent damage to either the instrument or equipment connected to it. If equipment is used in a manner not specified by the manufacturer, the protection provided by the equipment may be impaired.

### SPECIFICATIONS

- POWER:** 12 to 42 VDC \*(Loop powered). The power supply must have a 30 mA min. capacity.  
 [\* Min. voltage must be increased to include the drop across any current display indicator]
- INPUT:** RTD 2, 3, or 4 wire, 100 ohm platinum,  $\alpha=0.00385$  (DIN 43760),  $\alpha=0.00392$ , or resistance [selectable via DIP switch]  
**Excitation:** 0.170 mA nominal  
**Lead resistance:** Less than 0.5°C with 15 ohms max. per lead  
*Note: There is no lead compensation for 2 wire input. Field calibration should be accomplished with equivalent series resistance.*
- OUTPUT:** 4 to 20 mA Linear output with Temperature or resistance input.  
**Ripple:** Less than 15 mV peak-to-peak max., across 250Ω load resistor (up to 120 Hz frequencies).
- RANGE & ACCURACY:** (12 Bit resolution)  
**Accuracy:**  $\pm (0.075\% \text{ Range} + 0.1^\circ\text{C} [\text{Conformity}])$  at 23°C after 20 min. warm-up, conforming to ITS-90.

*Note: RTD conformity does not apply to resistance input.*

**Relative Humidity:** Less than 85% RH (non-condensing)

**Span:** The input span can be set to a min. of 1/8 of the full scale range, anywhere within that range.

**Range Accuracy:**

INPUT	RANGE	DIP SWITCH TYPE RANGE	TEMPERATURE & OHMS RANGE	RANGE ACCURACY
RTD $\alpha = 0.00385$	0	0 0 0 0	-160 to 654°C	$\pm 0.61^\circ\text{C}$
	1	0 0 0 1	-108 to 207°C	$\pm 0.24^\circ\text{C}$
	2	0 0 1 0	-5 to 414°C	$\pm 0.31^\circ\text{C}$
	3	0 0 1 1	194 to 608°C	$\pm 0.31^\circ\text{C}$
RTD $\alpha = 0.00392$	0	1 0 0 0	-157 to 640°C	$\pm 0.60^\circ\text{C}$
	1	1 0 0 1	-106 to 203°C	$\pm 0.23^\circ\text{C}$
	2	1 0 1 0	-5 to 406°C	$\pm 0.31^\circ\text{C}$
	3	1 0 1 1	190 to 596°C	$\pm 0.30^\circ\text{C}$
OHMS	0	0 1 0 0	35.5 to 331.0 Ω	$\pm 0.222 \Omega$
	1	0 1 0 1	57.0 to 178.5 Ω	$\pm 0.091 \Omega$
	2	0 1 1 0	98.0 to 252.0 Ω	$\pm 0.116 \Omega$
	3	0 1 1 1	173.5 to 316.5 Ω	$\pm 0.107 \Omega$

*Note: DIP switch settings ON = 1 OFF = 0*

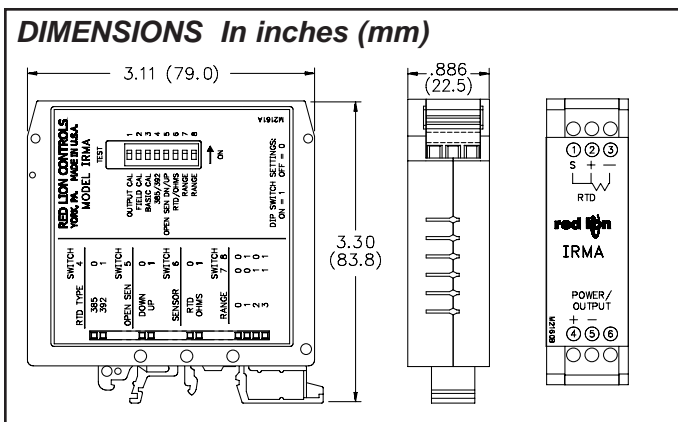

**CAUTION: Risk of Danger.**  
 Read complete instructions prior to installation and operation of the unit.

### ORDERING INFORMATION

MODEL NO.	DESCRIPTION	PART NUMBER
IRMA	Intelligent RTD Module	IRMA2003

## SPECIFICATIONS (Cont'd)

5. **SENSOR BREAK DETECTION:** Upscale to 22.5 mA (nominal) or Downscale to 3.6 mA (nominal) [selectable via DIP switch]
6. **RESPONSE TIME:** 400 msec (to within 99% of final value w/step input; typically, response is limited to response time of probe.)
7. **DIELECTRIC WITHSTAND VOLTAGE:** 1500 VAC for 1 minute  
**Working Voltage:** 50 VAC from input to output.
8. **CERTIFICATIONS AND COMPLIANCES:**  
**SAFETY**  
IEC 61010-1, EN 61010-1: Safety requirements for electrical equipment for measurement, control, and laboratory use, Part 1.

### ELECTROMAGNETIC COMPATIBILITY

#### Immunity to EN 50082-2

Electrostatic discharge	EN 61000-4-2	Level 2; 4 Kv contact <sup>1</sup> Level 3; 8 Kv air
Electromagnetic RF fields	EN 61000-4-3	Level 3; 10 V/m <sup>2</sup> 80 MHz - 1 GHz
Fast transients (burst)	EN 61000-4-4	Level 4; 2 Kv I/O Level 3; 2 Kv power
RF conducted interference	EN 61000-4-6	Level 3; 10 V/rms 150 KHz - 80 MHz
Power frequency magnetic fields	EN 61000-4-8	Level 4; 30 A/m

#### Emissions to EN 50081-2

RF interference	EN 55011	Enclosure class A
-----------------	----------	-------------------

#### Notes:

1. This device was designed for installation in an enclosure. To avoid electrostatic discharge, precautions should be taken when the device is mounted outside an enclosure. When working in an enclosure, (ex. making adjustments, setting switches etc.) typical anti-static precautions should be observed before touching the device.

2. Self-recoverable loss of performance during EMI disturbance at 10 V/m: Analog output signal may deviate during EMI disturbance.  
For operation without loss of performance:  
Unit is mounted in a metal enclosure (Buckeye SM7013-0 or equivalent). I/O and power cables are routed in metal conduit connected to earth ground.
9. **ENVIRONMENTAL CONDITIONS:**  
**Operating Temperature Range:** -25°C to 75°C (-13°F to 167°F)  
**Storage Temperature Range:** -40°C to 85°C (-40°F to 185°F)  
**Temperature Coefficient:** ± 0.01% of input range per °C  
**Altitude:** Up to 2000 meters.
10. **MOUNTING:** Universal mounting foot for attachment to standard DIN style mounting rails, including top hat (T) profile rail according to EN50022 - 35 x 7.5 and 35 x 15, and G profile rail according to EN50035 - G32.
11. **CONNECTION:** Compression type terminal block
12. **CONSTRUCTION:** High impact green plastic case
13. **WEIGHT:** 2.7 oz (76.54 g)

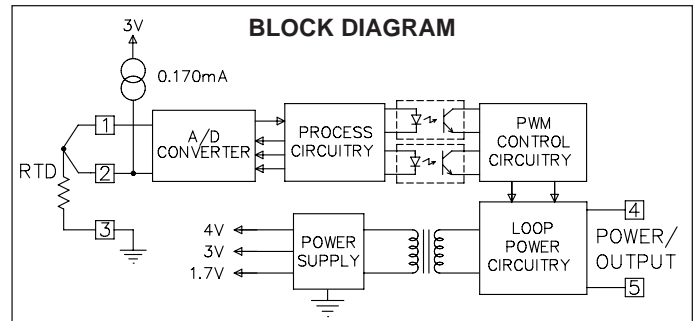

## FUNCTION DESCRIPTIONS

### Open Sensor Detection

The output can be set to go Upscale or Downscale for the detection of an open sensor. The Upscale setting makes the output go to 22.5 mA (nominal). The Downscale setting makes the output go to 3.5 mA (nominal). This setting is always active, so changes in the setting are effective immediately.

### Calibration Malfunction

If the unit has scaling problems (current remains at 3.5 mA nominal), check the voltage between the RTD- Input (-) and TEST pad (+) [located next to the DIP switches on the side of the unit]. For normal operation the voltage is 0 V (nominal). If the voltage is +3 V (nominal), a problem occurred storing information in the E<sup>2</sup>PROM. When this happens, perform a Basic Calibration and then a Field Calibration. Turn off power for 5 seconds. Turn on power and check the voltage between the TEST pad (+) and RTD- Input (-). If the voltage is still +3 V (nominal), contact the factory.

## EMC INSTALLATION GUIDELINES

Although this unit is designed with a high degree of immunity to ElectroMagnetic Interference (EMI), proper installation and wiring methods must be followed to ensure compatibility in each application. The type of electrical noise, source or coupling method into the unit may be different for various installations. In extremely high EMI environments, additional measures may be needed. For the purpose of EMC testing, both input and output lines on the unit were connected with 25 feet (8 m) of cable. Cable length, routing and shield termination are very important and can mean the difference between a successful or a troublesome installation. Listed below are some EMC guidelines for successful installation in an industrial environment.

1. Use shielded (screened) cables for all Signal and Control inputs. The shield (screen) pigtail connection should be made as short as possible. The connection point for the shield depends somewhat upon the application. Listed below are the recommended methods of connecting the shield, in order of their effectiveness.
  - a. Connect the shield only at the rail where the unit is mounted to earth ground (protective earth).
  - b. Connect the shield to earth ground at both ends of the cable, usually when the noise source frequency is above 1 MHz.
  - c. Connect the shield to common of the unit and leave the other end of the shield unconnected and insulated from earth ground.

2. Never run Signal or Control cables in the same conduit or raceway with AC power lines, conductors feeding motors, solenoids, SCR controls, and heaters, etc. The cables should be run in metal conduit that is properly grounded. This is especially useful in applications where cable runs are long and portable two-way radios are used in close proximity or if the installation is near a commercial radio transmitter.
3. Signal or Control cables within an enclosure should be routed as far away as possible from contactors, control relays, transformers, and other noisy components.
4. In extremely high EMI environments, the use of external EMI suppression devices, such as ferrite suppression cores, is effective. Install them on Signal and Control cables as close to the unit as possible. Loop the cable through the core several times or use multiple cores on each cable for additional protection. Install line filters on the power input cable to the unit to suppress power line interference. Install them near the power entry point of the enclosure. The following EMI suppression devices (or equivalent) are recommended:  
Ferrite Suppression Cores for signal and control cables:  
Fair-Rite # 0443167251 (RLC #FCOR0000)  
TDK # ZCAT3035-1330A  
Steward #28B2029-0A0  
Line Filters for input power cables:  
Schaffner # FN610-1/07 (RLC #LFIL0000)  
Schaffner # FN670-1.8/07  
Corcom #1VR3  
*Note: Reference manufacturer's instructions when installing a line filter.*
5. Long cable runs are more susceptible to EMI pickup than short cable runs. Therefore, keep cable runs as short as possible.

## WIRING CONNECTIONS

All conductors should meet voltage and current ratings for each terminal. Also, cabling should conform to appropriate standards of good installation, local codes and regulations. It is recommended that power supplied to the unit be protected by a fuse or circuit breaker. When wiring the unit, use the numbers on the label to identify the position number with the proper function. Strip the wire, leaving approximately 1/4" (6 mm) of bare wire exposed (stranded wire should be tinned with solder). Insert the wire into the terminal, and tighten the screw until the wire is clamped tightly.

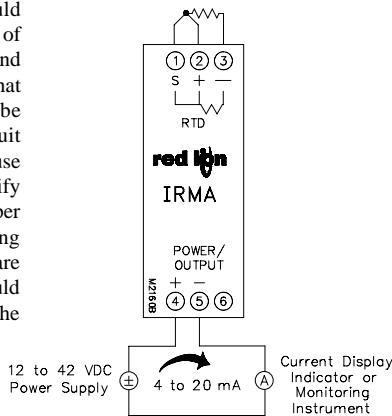

## INPUT AND POWER/OUTPUT CONNECTIONS

### INPUT

When connecting the RTD or resistance device, be certain that the connections are clean and tight. Attach the device to terminals #2 and #3. Install a copper sense lead of the same gauge as those used to connect the device. Attach one end of the wire at the probe where the lead connected to terminal #2 is attached and the other end to terminal #1. This configuration will provide complete lead wire compensation. If a sense wire is not utilized, then Terminal #1 should be shorted to terminal #2. To avoid errors due to lead wire resistance, field calibration should be performed with a series resistance equal to the total lead resistance in the system. Always refer to the probe manufacturer's recommendations for mounting, temperature range, shielding, etc.

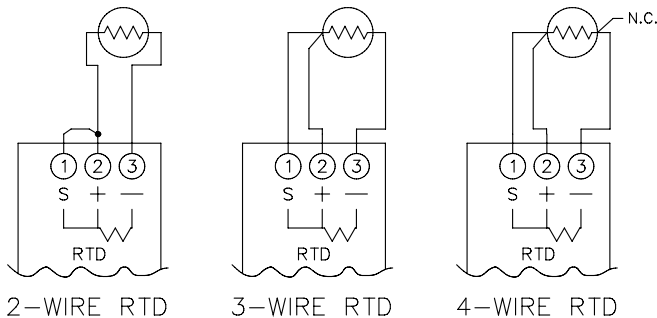

### POWER/OUTPUT

The unit has the power and current output sharing the same two wires (loop-powered). Connect DC power to terminals #4 and #5, observing the correct polarity, with a current meter/indicator connected in between so that the output current can be monitored. Be certain that the DC power is relatively "clean" and within the 12 to 42 VDC range at the terminals. The current meter voltage drop must be included in the power supply considerations.

## DIP SWITCH SETTING DESCRIPTIONS

SWITCH	DESCRIPTION	
1	OUTPUT CAL	Output Calibration
2	FIELD CAL	Field Calibration
3	BASIC CAL	Basic Calibration
4	385/392	Select RTD alpha - 0.00392 (ON) / 0.00385 (OFF)
5	OPEN SEN DN/UP	Open Sensor Detection - Upscale (ON) / Downscale (OFF)
6	RTD/OHMS	Select Input Type - Ohms (ON) / RTD (OFF)
7	RANGE	Sensor Range - 2 switch combination setting
8		

### Range switch settings (ON = 1 OFF = 0)

RANGE	DIP SWITCH	
	7	8
0	0	0
1	0	1
2	1	0
3	1	1

## FACTORY SETTINGS

The unit is shipped from the factory calibrated for a 4 to 20 mA output using a type 385 RTD in range 0. The IRMA should be calibrated by the operator for the application environment it will be used in. If the unit is not recalibrated by the operator, the following table lists the temperature ranges for each RTD type.

TYPE	RANGE	TEMPERATURE RANGE
385	0	150°C to 606°C
392	0	150°C to 595°C

# CALIBRATION PROCEDURES

## 1.0 Field Calibration

Allow a 30 minute warm-up period before starting Field Calibration. Field Calibration scales the 4 to 20 mA output to a temperature or resistance input. This procedure assigns an input value to 4 mA and an input value to 20 mA. The microprocessor handles configuring the output so it is linear to the temperature or resistance input. The Field Calibration procedure is described below.

*Note: The unit needs to have the Field Calibration completed by the operator before normal operation. To abort this calibration and reset to the previous settings, set the FIELD CAL switch OFF prior to the final OFF setting of the OUTPUT CAL switch (Step 1.11) and turn off power. Wait 5 seconds and then turn on power and the previous settings will be loaded.*

**RTD temperature to resistance conversion table**

Temperature °C	alpha 0.00385 ohms	alpha 0.00392 ohms	Temperature °C	alpha 0.00385 ohms	alpha 0.00392 ohms
-160	35.53	34.38	300	212.03	214.08
-150	39.71	38.64	350	229.69	232.07
-100	60.25	59.55	400	247.05	249.77
-50	80.30	79.96	410	250.49	253.28
0	100.00	100.00	450	264.13	267.18
50	119.40	119.75	500	280.92	284.30
100	138.5	139.20	550	297.42	301.13
150	157.33	158.36	590	310.41	314.38
190	172.17	173.48	600	313.63	317.66
200	175.85	177.23	640	326.38	330.68
250	194.09	195.80	650	329.54	333.90

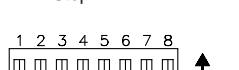
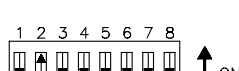
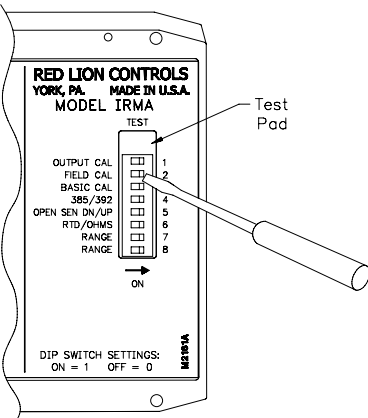
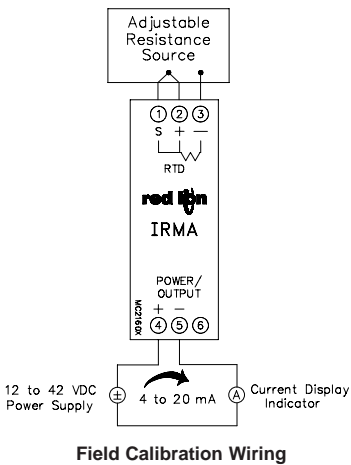

### Field Calibration with an Accurate Adjustable Resistance Source

- 1.1 Connect an Adjustable Resistance Source with an accuracy of 0.03% to the RTD input terminals using a third sense wire.  
For 2 wire sensors short terminal #1 to terminal #2.
- 1.2 Set the Type and Range for the RTD or resistance used in your application (DIP switches #4, #6, #7 and #8). (RTD alpha=0.00385, Range 0 shown)
- 1.3 Set the FIELD CAL switch (#2) ON. [Current goes to 3.6 mA (nominal)]
- 1.4 Set the resistance source to the desired resistance for the 4 mA output. For 2 wire sensors add the system lead resistance to the desired value.
- 1.5 Set the OUTPUT CAL switch (#1) ON. [Current stays at 3.6 mA (nominal)]
- 1.6 Adjust the input resistance up until the output equals 4 mA.
- 1.7 Set the OUTPUT CAL switch (#1) OFF. [Current increases to 22.3 mA (nominal)]
- 1.8 Set the resistance source to the desired resistance for the 20 mA output. For 2 wire sensors add the system lead resistance to the desired value.
- 1.9 Set the OUTPUT CAL switch (#1) ON. [Current decreases to 20.5 mA (nominal)]
- 1.10 Adjust the input resistance down until the output equals 20 mA.
- 1.11 Set the OUTPUT CAL switch (#1) OFF.
- 1.12 Set the FIELD CAL switch (#2) OFF.
- 1.13 Disconnect the resistance source from the IRMA and connect the actual sensor to be used in the application.

## 2.0 Basic Calibration (Factory Calibration)

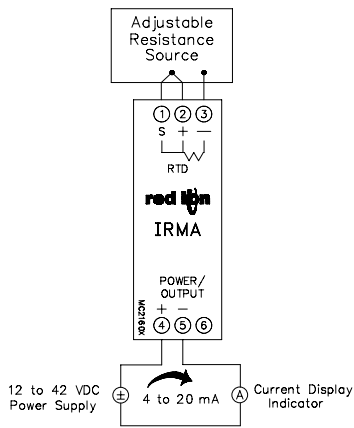

Basic Calibration Wiring

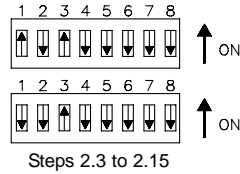
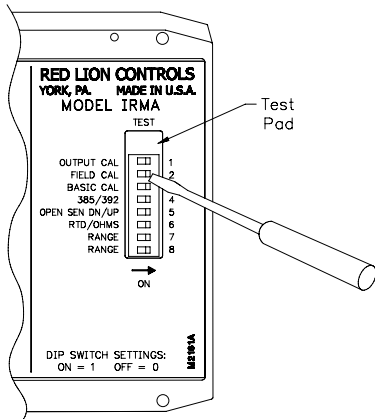

The Basic Calibration should only be performed with an ambient temperature between 21°C and 29°C. The Basic Calibration was performed on the unit at the factory and generally does not need to be done again. This procedure initializes the unit by calibrating the input circuitry. The Basic Calibration should be performed only if a condition exists as described in the "Calibration Malfunction" section. After completion of this calibration, the unit needs to be scaled in Field Calibration. The Basic Calibration procedure is described below.

*Note: To abort this calibration and reset to the previous settings, set the BASIC CAL switch OFF prior to the final setting of the OUTPUT CAL switch (Step 2.15) and turn off power for 5 seconds. Then turn on power and the previous settings will be loaded.*

- 2.1 Connect an Adjustable Resistance Source with an accuracy of 0.03% to the RTD input terminals using a third sense wire. Set the RANGE (#7&#8), TYPE (#4), OUTPUT CAL (#1), and FIELD CAL (#2) switches OFF. Set the BASIC CAL switch (#3) ON.
- 2.2 Apply power and allow a 30 minute warm-up period. [Current goes to 3.5 mA (nominal)]
- 2.3 Set the OUTPUT CAL switch (#1) ON and then OFF.
- 2.4 Set the resistance source to 40 ohms and wait 5 seconds.
- 2.5 Set the OUTPUT CAL switch (#1) ON and then OFF.
- 2.6 Set the resistance source to 60 ohms and wait 5 seconds.
- 2.7 Set the OUTPUT CAL switch (#1) ON and then OFF.
- 2.8 Set the resistance source to 100 ohms wait 5 seconds.
- 2.9 Set the OUTPUT CAL switch (#1) ON and then OFF.
- 2.10 Set the resistance source to 175 ohms and wait 5 seconds.
- 2.11 Set the OUTPUT CAL switch (#1) ON and then OFF.
- 2.12 Set the resistance source to 250 ohms and wait 5 seconds.
- 2.13 Set the OUTPUT CAL switch (#1) ON and then OFF.
- 2.14 Set the resistance source to 315 ohms and wait 5 seconds.
- 2.15 Set the OUTPUT CAL switch (#1) ON and then OFF.
- 2.16 Set the BASIC CAL switch (#3) OFF. [Current increases to 3.6 mA (nominal) or more]
- 2.17 Perform a Field Calibration. (See Section 1.0)

## INSTALLATION

The unit is equipped with a universal mounting foot for attachment to standard DIN style mounting rails, including G profile rail according to EN50035 - G32 , and top hat (T) profile rail according to EN50022 - 35 x 7.5 and 35 x 15. The unit should be installed in a location that does not exceed the maximum operating temperature and provides good air circulation. Placing the unit near devices that generate excessive heat should be avoided.

### G Rail Installation

To install the IRMA on a "G" style DIN rail, angle the module so that the upper groove of the "foot" catches under the lip of the top rail. Push the module toward the rail until it snaps into place. To remove a module from the rail, push up on the bottom of the module while pulling out away from the rail.

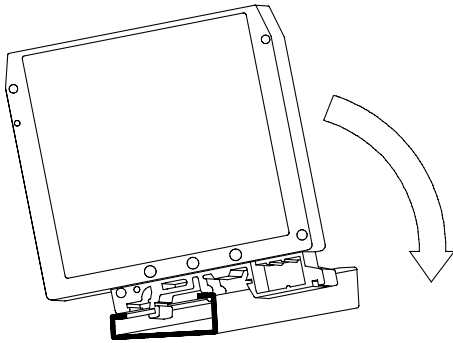

### T Rail Installation

To install the IRMA on a "T" style rail, angle the module so that the top groove of the "foot" is located over the lip of the top rail. Push the module toward the rail until it snaps into place. To remove a module from the rail, insert a screwdriver into the slot on the bottom of the "foot", and pry upwards on the module until it releases from the rail.

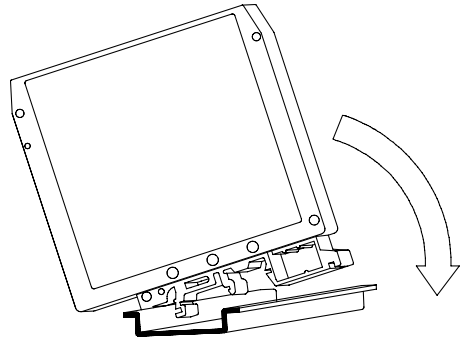

## APPLICATION

An aluminum manufacturer had the requirement to heat soak aluminum ingots before they were to advance into their hot roll mill. The system is being controlled by a PLC that allows the material to move to the next of twelve zones as soon as the aluminum ingot reaches the soak temperature. An IRMA, RTD Loop powered signal conditioner was used to transmit each zone temperature, measured by an RTD sensor, to the PLC. Because the heat soak procedure was accomplished in an eighty foot furnace tunnel, a relatively long wire run was required to connect each RTD with the PLC. The IRMA transmitter converts and linearizes the RTD signal into a 4 to 20 mA signal that can be run long distances to connect to the PLC.

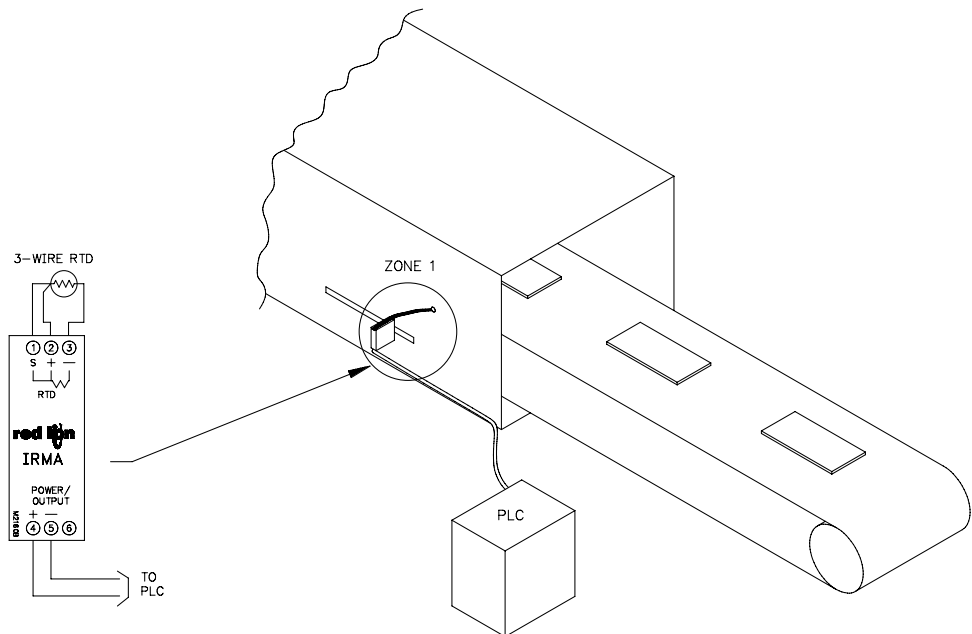

## TROUBLESHOOTING

For further technical assistance, contact technical support at the appropriate company numbers listed.