

MODEL LE - LINEAR CABLE ENCODER

- LOW COST LINEAR SOLUTION
- 50 OR 500 PULSES PER INCH
- STAINLESS STEEL CABLE
- 0 TO 50 INCHES OF CABLE MEASUREMENT



DESCRIPTION

The Linear Cable Encoder can provide an accurate, yet low cost solution for Linear Measurement applications. Common applications include robotics, extrusion presses, valve positioning, textile machinery, and gate control positioning, just to name a few. The LE has some unique advantages over other sensing solutions. Using a stainless steel cable, perfect parallel alignment is no longer required and with a 50 inch cable reach, it can easily be mounted away from harsh environments. The LE is available in a quadrature output, allowing the sensor to operate in positioning applications.

Additional cable exit configurations, pulses per inch, and mating connectors are available on special request. Contact the factory for details.

SPECIFICATIONS

1. **INPUT VOLTAGE:** 4.75 to 28 VDC
2. **INPUT CURRENT:** 80 mA maximum with no output load
3. **RIPPLE:** 100 mV peak-to-peak at 0 to 100 KHz
4. **OUTPUT FORMAT:** Incremental; square wave with channel A leading B during linear extension in quadrature models.
5. **OUTPUT TYPE:** NPN open collector; 250 mA max per channel
6. **FREQ RESPONSE:** 0 to 125 KHz
7. **SYMMETRY:** 180° ($\pm 18^\circ$) electrical
8. **QUAD PHASING:** 90° ($\pm 22.5^\circ$) electrical
9. **RISE TIME:** Less than 1 μ sec
10. **FULL STROKE LENGTH (FSL):** 50" standard. Longer measuring ranges may be available, please contact customer service
11. **FINISH:** Black powder coated aluminum
12. **ACCURACY:** $\pm 0.10\%$ FSL
13. **REPEATABILITY:** $\pm 0.015\%$ FSL
14. **LINEAR RESOLUTION:** Up to 500 cycles per inch (0.002" per cycle)
15. **CABLE MATERIAL:** 0.034" nylon coated stainless steel rope
16. **CABLE TENSION:** 20 oz maximum typical
17. **LIFE (CYCLES):** 1,000,000 predicted at zero angle cable exit
18. **OPERATING TEMPERATURE:** 0 to 85°C

DIMENSIONS In inches (mm)

LE

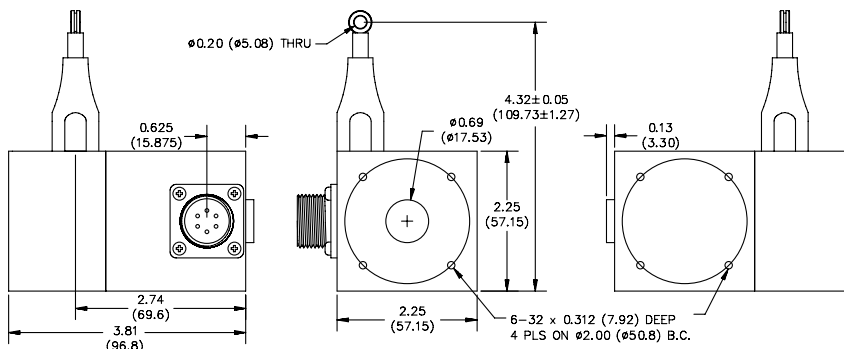

LEMTBR00

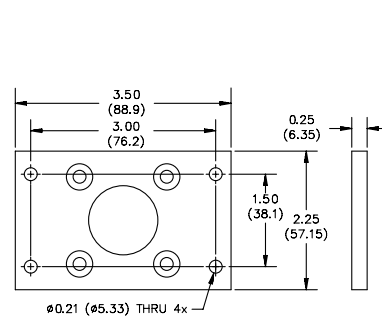

LE ELECTRICAL CONNECTIONS

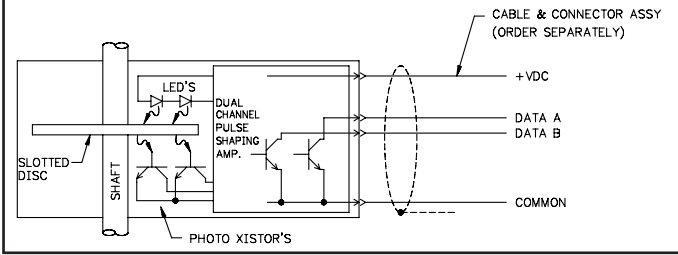

LE WIRING SPECIFICATIONS

LE PIN	FUNCTION	CCARPG WIRE
A	+VOLTS DC	RED
B	COMMON	BLACK
C	DATA A	WHITE
D	DATA B	GREEN
E	NO CONNECTION	

ORDERING INFORMATION

MODEL NO.	DESCRIPTION	PART NUMBER
LE	Quadrature output, 50 PPI, Standard Housing	LES1050S
	Quadrature output, 500 PPI, Standard Housing	LES1500S
	Special Configurations for LE (Contact Factory)	LE999999
	LE Mounting Bracket	LEMTBR00
	Mating 6-Pin MS Connector	2101100
	10' 6-Pin 4-Wire Cable/Connector	CCARPG01
	25' 6-Pin 4-Wire Cable/Connector	CCARPG25
	50' 6-Pin 4-Wire Cable/Connector	CCARPG50

LIMITED WARRANTY

The Company warrants the products it manufactures against defects in materials and workmanship for a period limited to two years from the date of shipment, provided the products have been stored, handled, installed, and used under proper conditions. The Company's liability under this limited warranty shall extend only to the repair or replacement of a defective product, at The Company's option. The Company disclaims all liability for any affirmation, promise or representation with respect to the products.

The customer agrees to hold Red Lion Controls harmless from, defend, and indemnify RLC against damages, claims, and expenses arising out of subsequent sales of RLC products or products containing components manufactured by RLC and based upon personal injuries, deaths, property damage, lost profits, and other matters which Buyer, its employees, or sub-contractors are or may be to any extent liable, including without limitation penalties imposed by the Consumer Product Safety Act (P.L. 92-573) and liability imposed upon any person pursuant to the Magnuson-Moss Warranty Act (P.L. 93-637), as now in effect or as amended hereafter.

No warranties expressed or implied are created with respect to The Company's products except those expressly contained herein. The Customer acknowledges the disclaimers and limitations contained herein and relies on no other warranties or affirmations.