

MODEL LIBC - LIBRA SERIES COUNTERS (LCD & LED)



- ABILITY TO LOCK OUT FRONT PANEL FUNCTIONS
- SEALED FRONT PANEL CONSTRUCTION (NEMA 4/IP65)
- ONE OR TWO PRESET VERSIONS
- 0.5" HIGH LIQUID CRYSTAL DISPLAY OR 0.4" HIGH LED DISPLAY
- ACCEPTS INPUT COUNT RATE UP TO 2500 CPS
- BI-DIRECTIONAL COUNTING
- SOLID-STATE CURRENT SINK OUTPUT(S)
- FORM C RELAY OUTPUT(S)
- PROGRAMMABLE TIMED OUTPUT (0.01 sec to 99.99 sec.)
- SIMPLE FRONT PANEL FOR PROGRAMMING EASE
- FRONT PANEL PROGRAMMABLE DECIMAL POINTS
- MEETS DIN PANEL MOUNT SPECIFICATIONS
- REMOTE RESET CAPABILITY
- NON-VOLATILE MEMORY (E²PROM)
- ON-LINE SELF-TEST



DESCRIPTION

The Libra Series of presettable counters is an economical and reliable solution to one or two preset level requirements. The LIBC1 and LIBC1E are the single preset versions and the LIBC2 and LIBC2E are the dual preset versions. All four units have a solid-state output and a Form C relay output for each preset. These units feature input configuration programmability, a full complement of control inputs, programmable timed outputs, non-volatile memory, and many other features which will satisfy most any single or dual preset level requirement.

The Libra counters have two main counting actions, Reset to Zero (RTZ) and Reset to Preset (RTP). With RTZ, the counter resets to zero and counts up (if UP/DN terminal is at high level) and activates the outputs when the preset value(s) are reached. When RTP is used, the unit starts at the preset value and counts down (if the UP/DN terminal is at low level) and activates the output when zero is reached. For the 2-preset version, the count starts at preset 2 and counts toward zero. Output 1 fires when preset 1 value is reached and output 2 fires when the count reaches zero. There are eight modes of operation for the single preset unit and sixteen modes of operation for the dual preset unit.

The timed output is programmed through the front panel buttons and can be programmed from 0.01 sec. to 99.99 sec. (The unit's timed output is set at the factory to be 0.1 sec.) The Libra counters have an internal non-volatile memory

device which eliminates the need for battery back-up. When input power is removed, this device will maintain all data necessary for system operation. A Program Disable terminal is available, which is used to prevent accidental changes or tampering by unauthorized personnel to the preset(s) or timed output value(s). The front panel reset button can also be enabled or disabled by a rear panel DIP switch. These counters also have an on-line self-test, which checks all display driver and micro-processor hardware. The self-test can be run at any time without losing counts or missing a preset value.

Power, input, and output connections are made via removable terminal strips located at the rear of the unit. These strips can accept one #14 AWG stripped wire. DIP switches at the rear of the unit are used to program the input configuration and to set the desired operating modes.

The Libra Series counters have a metal die-cast front bezel, which is sealed, and meets NEMA 4/IP65 specifications for wash-down and/or dust when properly installed. Mounting clips are provided for easy panel installation.

SAFETY SUMMARY

All safety related regulations, local codes and instructions that appear in the manual or on equipment must be observed to ensure personal safety and to prevent damage to either the instrument or equipment connected to it. If equipment is used in a manner not specified by the manufacturer, the protection provided by the equipment may be impaired.

Do not use this unit to directly command motors, valves, or other actuators not equipped with safeguards. To do so, can be potentially harmful to persons or equipment in the event of a fault to the unit.

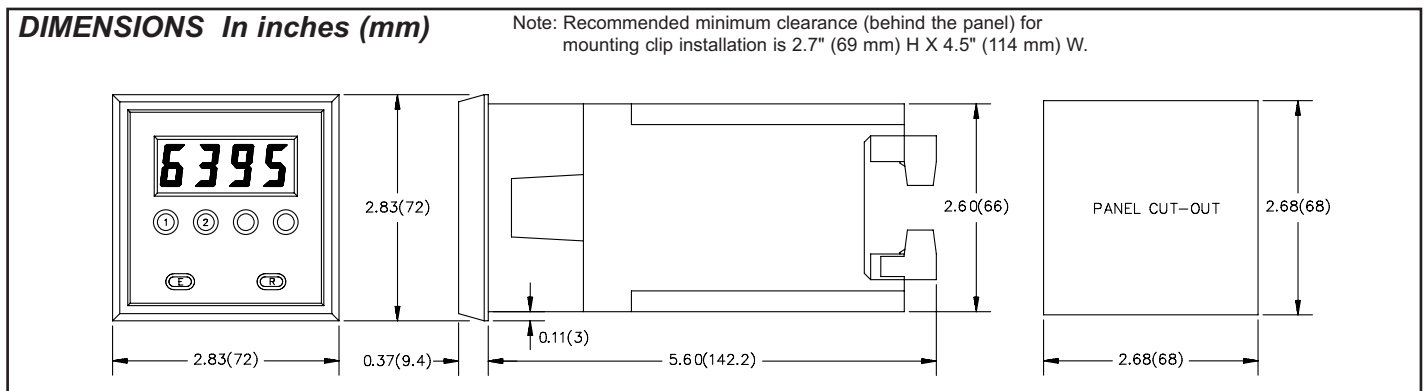
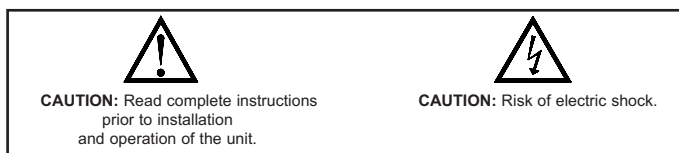

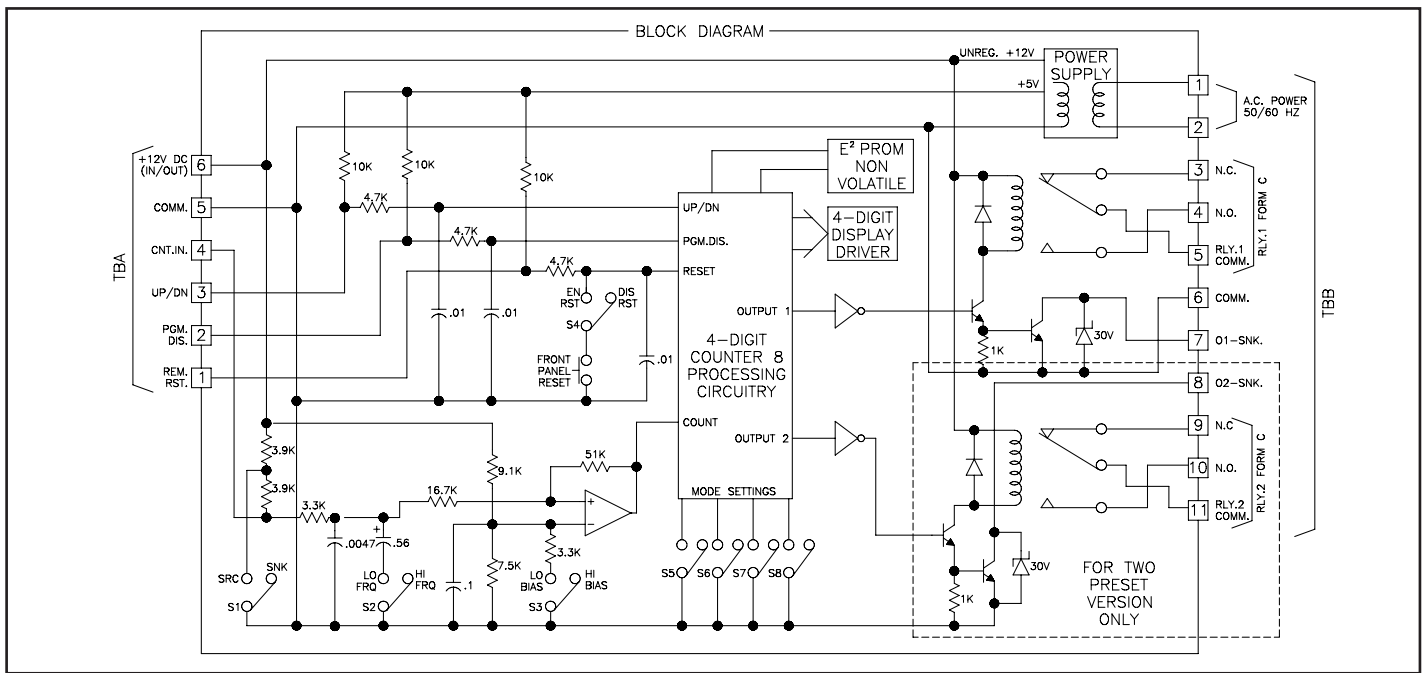

SPECIFICATIONS

- DISPLAY:** 4-digit, 0.5" (12.7 mm) high LCD display.
4-digit, 0.4" (10.2 mm) high LED display.
- POWER REQUIREMENTS:**
AC Operation: 115/230 VAC ($\pm 10\%$), 50/60 Hz, 6 VA (LCD) or 9 VA (LED).
DC Operation: 11 to 14 VDC @ 0.2 A max. (LCD) or 0.3 A max. (LED).
- SENSOR POWER:** +10 to 16 VDC @ 150 mA.
- COUNT INPUT:** Switch selectable to accept count pulses from a variety of sources including switch contacts, outputs from CMOS or TTL circuits, and all standard RLC sensors.
Current Sourcing - Unit provides 3.9 K Ω pull-down load for sensors with current sourcing outputs. (Max. input voltage 28 VDC @ 7 mA)
Current Sinking - Unit provides 7.8 K Ω pull-up load for sensors with current sinking outputs. (Max. sensor current, 1.6 mA)
Debounce - Damping capacitor provided for switch contact debounce. Limits count speed to 100 Hz max. and input pulse widths of 5 msec min.
Lo Bias - Input Trigger levels $V_{IL} = 1.5$ V, $V_{IH} = 3.75$ V.
Hi Bias - Input Trigger levels $V_{IL} = 5.5$ V, $V_{IH} = 7.5$ V.
Note: Bias levels $\pm 10\%$ @ 12 VDC sensor voltage. These levels vary proportionally with the sensor supply voltage.
- MAXIMUM COUNT RATES:**
High Frequency - 2.5 KHz max. for all electronic sensors under all modes of operation. Signals can be square wave inputs or inputs with negative going pulse widths, as short as 50 μ sec, with a total min. period of 400 μ sec.
Low Frequency - 100 Hz for switch contact closures. (*Note: These units will operate with VCM [E-H] modules.*)
- CONTROL INPUTS:**
Remote Reset - Active low ($V_{IL} = 0.5$ V max.), internally pulled up to 5 VDC through a 10 K Ω resistor ($I_{SNK} = 0.5$ mA). Response time = 10 msec. A low will reset the unit and deactivate outputs.
Program Disable - Active low ($V_{IL} = 0.5$ V max.), internally pulled up to 5 VDC through a 10 K Ω resistor ($I_{SNK} = 0.5$ mA). A low will inhibit the changing of presets, decimal point selection, and timed outputs, as well as testing outputs in self-test.
Up/Dn Control - Active low ($V_{IL} = 0.5$ V max.), internally pulled up to 5 VDC through a 10 K Ω resistor ($I_{SNK} = 0.5$ mA) Response Time = 150 μ sec. This input determines the direction of the count and is independent of Reset to Zero or Reset to Preset modes of operation. When input is low, count is down.
- OUTPUTS:**
Solid-State - Current sinking NPN open collector transistors. $I_{SNK} = 100$ mA max. $V_{OH} = 30$ VDC max. (Internal Zener diode protection). One solid-state output for each preset level. $V_{OL} = 1$ VDC max. @ 100 mA.
Relay(s) - Form C contacts max. rating 5 amps @ 120/240 VAC, 28 VDC (resistive load), 1/8 H.P. @ 120 VAC (inductive load). The operate time is 5 msec nominal and the release time is 3 msec nominal.
Relay Life Expectancy - 100,000 cycles at max. rating. (As load level decreases, life expectancy increases.)

Programmable Timed Output - The timed output can be programmed from 0.01 sec to 99.99 sec, $\pm 0.01\%$ - 10 msec. The timed output is set for 0.1 sec at the factory.

- MEMORY RETENTION:** The Libra counters have a "no power E²PROM" which maintains all information when the input power is removed. The life expectancy of this device is at least 100,000 power down cycles and length of memory retention for a single power down can be as long as 10 years.
- INPUT, POWER, AND OUTPUT CONNECTIONS:** There are two plug-in, compression type, barrier strips located at the rear of the unit. These strips can be removed from the rear of the unit for ease of wiring. After wiring is complete, the connector can be plugged back into the unit.

10. CERTIFICATIONS AND COMPLIANCES: SAFETY

Type 4 Indoor Enclosure rating (Face only), UL50

IEC 1010-1, EN 61010-1: Safety requirements for electrical equipment for measurement, control, and laboratory use, Part 1.

IP65 Enclosure rating (Face only), IEC 529

ELECTROMAGNETIC COMPATIBILITY

Immunity to EN 50082-2

Electrostatic discharge	EN 61000-4-2	Level 2; 4 Kv contact ¹ Level 3; 8 Kv air
Electromagnetic RF fields	EN 61000-4-3	Level 3; 10 V/m 80 MHz - 1 GHz
Fast transients (burst)	EN 61000-4-4	Level 4; 2 Kv I/O ² Level 3; 2 Kv power
RF conducted interference	EN 61000-4-6	Level 3; 10 V/rms ² 150 KHz - 80 MHz
Power frequency magnetic fields	EN 61000-4-8	Level 4; 30 A/m

Emissions to EN 50081-2

RF interference	EN 55011	Enclosure class B Power mains class B
-----------------	----------	--

Notes:

- Metal bezel of unit connected with ground lead from rear bezel screw to metal mounting panel.
- When the unit is DC powered from terminal TBA pin 5 (common) and terminal TBB pin 6 (+12 VDC) a power line filter was installed, RLC #LFIL0000 or equivalent, so as not to impair the function of the unit.

Refer to the EMC Installation Guidelines for additional information.

11. ENVIRONMENTAL CONDITIONS:

Operating Temperature: 0 to 50°C

Storage Temperature: -40 to 70°C

Operating and Storage Humidity: 85% max. (non-condensing) from 0°C to 50°C.

Altitude: Up to 2000 meters

- CONSTRUCTION:** Metal die-cast bezel with black, high impact plastic insert. Front panel meets NEMA 4/IP65 requirements for indoor use when properly installed. (Panel gasket and mounting clips included with unit.) Installation Category II, Pollution Degree 2.

- WEIGHT:** 1.5 lbs. (0.68 k) [LCD], 1.75 lbs. (0.79 k) [LED]

MODES OF OPERATION

Mode settings of the switches are shown to the right of the text below. The mode number corresponds to a binary code, represented by the DIP switch positions. When the switch is "UP", it is equivalent to a zero. When the switch is "DOWN", it is equivalent to a one. The mode switch settings can be easily observed from the panel front by using the self-test. At the end of self-test, the state of these mode switches are displayed.

NOTES:

- For all the following modes of operation, when the unit is set for a Reset to Zero mode, the UP/DN terminal (count direction) is normally left high (in

"UP" position). When the unit is set for a Reset to Preset mode, the UP/DN terminal is normally tied to common (in "DOWN" position). However, even though these are the usual conditions for the UP/DN terminal, it does not have to operate in this fashion. For example: the unit can count down in a Reset to Zero mode or count up in a Reset to Preset mode and still maintain normal operating functions.

- The timed output must be less than the time required to count from the reset condition to the preset point. Otherwise, the output will appear to be latched-on.

MODES OF OPERATION FOR SINGLE PRESET LIBRA COUNTER

MODE 0 LATCH OUTPUT AT PRESET, MANUAL RESET TO ZERO

In this mode, as the unit counts from zero, the output will latch on when the preset is reached. When a manual reset occurs, the unit will Reset to Zero and the output, if latched on, will unlatch. Counts will continue to accumulate after the output has turned on.



MODE 1 TIMED OUTPUT AT PRESET, MANUAL RESET TO ZERO

In this mode, as the unit counts from zero, the output will turn on when the preset is reached. The output will turn off after its programmed time value has occurred. When a manual reset occurs, the unit will Reset to Zero. Manual reset will terminate the timed output, if the output is still activated. Counts will continue to accumulate after the preset level has been reached.



MODE 2 & 3 - ♦♦

MODE 4 TIMED OUTPUT AT PRESET, AUTOMATIC RESET TO ZERO AT PRESET

In this mode, as the unit counts from zero, the output will turn on when the preset is reached. At the same time, the unit will automatically Reset to Zero and start the cycle over again. The output will turn off after its programmed time value has occurred. Manual reset will turn off the output, if turned on, and reset the count to zero. During automatic reset, no counts will be lost if the count rate does not exceed 2,500 cps.



MODE 5 - ♦♦

MODE 6 TIMED OUTPUT AT PRESET, AUTOMATIC RESET TO ZERO AFTER THE TIMED OUTPUT

In this mode, as the unit counts from zero, the output will turn on when preset 1 is reached. The output will turn off after its programmed time value has occurred. At the end of the timed output, the unit will automatically Reset to Zero and start the cycle over again. During automatic reset, no counts will be lost, as long as the count rate does not exceed 2,500 cps. Manual reset will turn off the output, if turned on, and reset the count to zero.



MODE 7 - ♦♦

♦ Manual reset, either by front panel reset (if enabled) or remote reset, is always active, and will override any condition or state the counter is presently in.

MODE 8 LATCH OUTPUT AT ZERO, MANUAL RESET TO PRESET †

In this mode, as the unit counts from preset, the output will turn on when zero is reached. The output will turn off after its programmed time value has occurred. When a manual reset occurs, the unit will Reset to Preset and the output, if latched on, will unlatch. Counts will continue to register after the outputs turn on.



MODE 9 TIMED OUTPUT AT ZERO, MANUAL RESET TO PRESET †

In this mode, as the unit counts from preset, the output will turn on when zero is reached. The output will turn off after its programmed time value has occurred. When a manual reset occurs, the unit will Reset to Preset. Manual reset will terminate the timed output if the output is still activated. Counts will continue to accumulate after the output has activated.



MODE 10 & 11 - ♦♦

MODE 12 TIMED OUTPUT AT ZERO, AUTOMATIC RESET TO PRESET AT ZERO †

In this mode, as the unit counts from preset, the output will turn on when zero is reached. At this time, the unit will automatically Reset to Preset. The output will turn off after its programmed time value has occurred. Manual reset will turn off the output, if turned on, and reset the count to preset. During automatic reset, no counts will be lost if the count rate does not exceed 2,500 cps.



MODE 13 - ♦♦

MODE 14 TIMED OUTPUT AT ZERO, AUTOMATIC RESET TO PRESET AFTER THE TIMED OUTPUT †

In this mode, as the unit counts from preset, the output will turn on when zero is reached. The output will turn off after its programmed time value has occurred. At the end of the timed output, the unit will automatically Reset to Preset and start the cycle over. During automatic reset, no counts will be lost, as long as the count rate does not exceed 2,500 cps. Manual reset will turn off the output, if turned on, and reset the count to preset.



MODE 15 - ♦♦

† When down count is desired, (such as reset to preset modes of operation) the "UP/DN" terminal must be tied to the "COMM." terminal.

♦♦ These modes are not applicable to the single preset Libra counter (they are used only for the two preset counter unit).

MODES OF OPERATION FOR DUAL PRESET LIBRA COUNTER

MODE 0 LATCH OUTPUT AT PRESET, MANUAL RESET TO ZERO

In this mode, as the unit counts from zero, output 1 will latch on when preset 1 is reached, and output 2 will latch on when preset 2 is reached. When a manual reset occurs, the unit will Reset to Zero and the outputs, if latched on, will unlatch. Counts will continue to accumulate after the outputs have turned on.



MODE 1 TIMED OUTPUTS AT PRESETS, MANUAL RESET TO ZERO

In this mode, as the unit counts from zero, output 1 will turn on when preset 1 is reached, and output 2 will turn on when preset 2 is reached. The outputs will turn off after their respective programmed time values have occurred. When a manual reset occurs, the unit will Reset to Zero. Manual reset will terminate the timed outputs, if the outputs are still turned on. Counts will continue to accumulate after the preset levels have been reached.



♦ Manual reset, either by front panel reset (if enabled) or remote reset, is always active, and will override any condition or state the counter is presently in.

MODE 2 OUTPUT 1 TURN OFF AT PRESET 2, LATCH OUTPUT 2 AT PRESET 2, MANUAL RESET TO ZERO

In this mode, as the unit counts from zero, output 1 will turn on when preset 1 is reached. When preset 2 is reached, output 2 will turn on and output 1 will turn off. Output 2 will remain latched on until a manual reset occurs. Manual reset will turn off both outputs and the unit will Reset to Zero. Counts will continue to accumulate after the preset levels have been reached.



MODE 3 OUTPUT 1 TURN OFF AT PRESET 2, TIMED OUTPUT 2 AT PRESET 2, MANUAL RESET TO ZERO

In this mode, as the unit counts from zero, output 1 will turn on when preset 1 is reached. When preset 2 is reached, output 2 will turn on and output 1 will turn off. Output 2 will turn off after its programmed time value has occurred. When a manual reset occurs, the unit will Reset to Zero. Manual reset will also turn off both outputs if they are still activated. Counts will continue to accumulate after preset levels have been reached.



(Modes Cont'd)

MODES OF OPERATION FOR DUAL PRESET LIBRA COUNTER (Cont'd)

MODE 4 OUTPUT 1 TURN OFF AT PRESET 2, TIMED OUTPUT 2 AT PRESET 2, AUTOMATIC RESET TO ZERO AT PRESET 2

In this mode, as the unit counts from zero, output 1 will turn on when preset 1 is reached. When preset 2 is reached, output 2 will turn on, output 1 will turn off, and the unit will automatically Reset to Zero. Output 2 will turn off after its programmed time value has occurred. Manual reset[♦] will turn off both outputs, if activated, and reset the count to zero. During automatic reset, no counts will be lost as long as the count rate does not exceed 2,500 cps.



MODE 5 TIMED OUTPUTS AT PRESETS, AUTOMATIC RESET TO ZERO AT PRESET 2

In this mode, as the unit counts from zero, output 1 will turn on when preset 1 is reached and output 2 will turn on when preset 2 is reached. The outputs will turn off after their respective programmed time values have occurred. Also, when preset 2 is reached, the unit will automatically reset the count to zero and start the cycle over. (Output 2 will remain on until its time value has occurred.) Manual reset[♦] will turn off both outputs and reset the count to zero. During automatic reset, no counts will be lost, as long as the count rate does not exceed 2,500 cps.



MODE 6 OUTPUT 1 TURN OFF AT PRESET 2, TIMED OUTPUT 2 AT PRESET 2, AUTOMATIC RESET TO ZERO AFTER TIMED OUTPUT 2

In this mode, as the unit counts from zero, output 1 will turn on when preset 1 is reached. When preset 2 is reached, output 2 will turn on and output 1 will turn off. Output 2 will turn off after its programmed time value has occurred. At the end of timed output 2, the unit will automatically Reset to Zero and start the cycle over again. During automatic reset, no counts will be lost as long as the count rate does not exceed 2,500 cps. Manual reset[♦] will turn off both outputs, if turned on, and reset the count to zero.



MODE 7 TIMED OUTPUTS AT PRESETS, AUTOMATIC RESET TO ZERO AFTER TIMED OUTPUT 2

In this mode, as the unit counts from zero, output 1 will turn on when preset 1 is reached and output 2 will turn on when preset 2 is reached. The outputs will turn off after their respective programmed time values have occurred. At the end of timed output 2, the unit will automatically Reset to Zero and start the cycle over again. During automatic reset, no counts will be lost, as long as the count rate does not exceed 2,500 cps. Manual reset[♦] will turn off both outputs, if turned on, and reset the count to zero.



MODE 8 LATCH OUTPUT AT PRESET 1 AND ZERO, MANUAL RESET TO PRESET 2 †

In this mode, as the unit counts from preset 2, output 1 will latch on when preset 1 is reached and output 2 will latch on when zero is reached. When a manual reset[♦] occurs, the unit will Reset to Preset 2 and the output, if latched on, will unlatch. Counts will continue to register after the outputs have turned on.



MODE 9 TIMED OUTPUT AT PRESET 1 AND ZERO, MANUAL RESET TO PRESET 2 †

In this mode, as the unit counts from preset 2, output 1 will turn on when preset 1 is reached and output 2 will turn on when zero is reached. The outputs will turn off after their respective programmed time values have occurred. When a manual reset[♦] occurs, the unit will Reset to Preset 2. Manual reset will terminate the timed outputs, if the outputs are still activated. Counts will continue to accumulate after the outputs have activated.



† When down count is desired, (such as reset to preset modes of operation) the "UP/DN" terminal must be tied to the "COMM." terminal.

♦ Manual reset, either by front panel reset (if enabled) or remote reset, is always active, and will override any condition or state the counter is presently in.

MODE 10 OUTPUT 1 TURN OFF AT ZERO, LATCH OUTPUT 2 AT ZERO, MANUAL RESET TO PRESET 2 †

In this mode, as the unit counts from preset 2, output 1 will turn on when preset 1 is reached. When zero is reached, output 2 will turn on and output 1 will turn off. Output 2 will remain latched on until a manual reset occurs. Counts will continue to accumulate after preset levels have been reached. Manual reset[♦] will turn off all outputs if activated and the unit Resets to Preset 2.



MODE 11 OUTPUT 1 TURN OFF AT ZERO, TIMED OUTPUT 2 AT ZERO, MANUAL RESET TO PRESET 2 †

In this mode, as the unit counts from preset 2, output 1 will turn on when preset 1 is reached. When zero is reached, output 2 will turn on and output 1 will turn off. Output 2 will turn off after its programmed time value has occurred. Counts will continue to accumulate after preset levels have been reached. When a manual reset[♦] occurs, the unit will Reset to Preset 2. Manual reset will also turn off both outputs, if still activated.



MODE 12 OUTPUT 1 TURN OFF AT ZERO, TIMED OUTPUT 2 AT ZERO, AUTOMATIC RESET TO PRESET 2 AT ZERO †

In this mode, as the unit counts from preset 2, output 1 will turn on when preset 1 is reached. When zero is reached, output 2 will turn on, output 1 will turn off, and the unit will automatically Reset to Preset 2. Output 2 will turn off after its programmed time value has occurred. Manual reset[♦] will turn off both outputs, if turned on, and reset the count to preset 2. During automatic reset, no counts will be lost if the count rate does not exceed 2,500 cps.



MODE 13 TIMED OUTPUTS AT PRESET 1 AND ZERO, AUTOMATIC RESET TO PRESET 2 AT ZERO †

In this mode, as the unit counts from preset 2, output 1 will turn on when preset 1 is reached and output 2 will turn on when zero is reached. The outputs will turn off after their respective programmed time values have occurred. Also, when zero is reached, the unit will automatically reset the count to preset 2 and start the cycle over. (Output 2 will remain on until its time value has occurred.) Manual reset[♦] will turn off both outputs, if turned on, and reset the count to preset 2. During automatic reset, no counts will be lost, as long as the count rate does not exceed 2,500 cps.



MODE 14 OUTPUT 1 TURN OFF AT ZERO, TIMED OUTPUT 2 AT ZERO, AUTOMATIC RESET TO PRESET 2 AFTER TIMED OUTPUT 2 †

In this mode, as the unit counts from preset 2, output 1 will turn on when preset 1 is reached. When zero is reached, output 2 will turn on and output 1 will turn off. Output 2 will turn off after its programmed time value has occurred. At the end of timed output 2, the unit will automatically Reset to Preset 2 and start the cycle over. During automatic reset, no counts will be lost, as long as the count rate does not exceed 2,500 cps. Manual reset[♦] will turn off both outputs, if activated, and reset the count to preset 2.



MODE 15 TIMED OUTPUTS AT PRESET 1 AND ZERO, AUTOMATIC RESET TO PRESET 2 AFTER TIMED OUTPUT 2 †

In this mode, as the unit counts from preset 2, output 1 will turn on when preset 1 is reached and output 2 will turn on when zero is reached. The outputs will turn off after their respective programmed time values have occurred. At the end of timed output 2, the unit will automatically Reset to Preset 2 and start the cycle over. During automatic reset, no counts will be lost, as long as the count rate does not exceed 2,500 cps. Manual reset[♦] will turn off either output, if turned on, and reset the count to preset 2.



SELECTION OF INPUT SET-UP & MODES OF OPERATION

The selection of Input Set-up and Modes of Operation is accomplished by eight DIP switches, located at the rear of the unit, in the upper right-hand corner. DIP switches 1 to 3 are used to configure the input, and DIP switches 5 to 8 are used to determine the modes of operation. DIP switch 4 is used to enable or disable the front panel reset button. The input set-up and reset enable switches will be discussed first. Refer to the block diagram of the unit for the details of count and control circuitry.

SWITCH SET-UP

S1 - SNK: Provides a 7.8 K Ω pull-up resistor for sensors with sinking outputs.

SRC: Provides a 3.9 K Ω pull-down resistor for sensors with sourcing outputs.

S2 - HI FRQ: Removes damping capacitor and allows operation up to 2.5 KHz. Minimum count OFF times - 50 μ sec.

LO FRQ: Connects damping capacitor for switch contact debounce. Limits count speed to 100 Hz. Minimum count pulses ON/OFF times - 5 msec.

S3 - HI BIAS: Sets input trigger levels at mid-range to accept outputs from 2-wire proximity sensors, resistive photo-cells, and logic pulses with full 0 to +12 V swings. ($V_{IL} = 5.5$ V, $V_{IH} = 7.5$ V)

LO BIAS: Sets input trigger levels to the low range to accept logic pulses with 0 to 5 V swings. ($V_{IL} = 1.5$ V, $V_{IH} = 3.75$ V)

S4 - DIS RST: Disables front panel reset.

EN RST: Enables front panel reset.

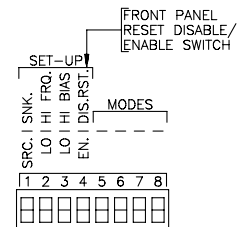

POWER-UP DIAGNOSTICS

The Libra counters have internal diagnostics which will check the stored data during power-up. When the data is saved (*power-down*), computations are made with these values. The result of these computations is stored in the memory to serve as a check against possible error. Then on power-up, these same computations are repeated on the stored data. If these results do not agree with the stored results, then a "P" will appear on the right side of the display. Normal operation of the unit will continue while this "P" is displayed. To remove the "P" from the display, press the "E" button. Then check programmed values to be certain they are correct.

TO ENTER A DECIMAL POINT INTO THE DISPLAY

FIRST: Press the button located under the right-hand digit. At this time, the display will "freeze". (*The display will remain "frozen" approximately 5 seconds after release of this button, if no other buttons are pushed.*) During the selection of decimal point, the unit will operate normally.

SECOND: Press the button located under the desired decimal point location. (*The decimal point will appear to the right of the digit.*) (*This selection cannot be made when "PGM. DIS." is activated.*) Pressing the button located under the right-hand digit will display no decimal point. (*This will turn off any displayed decimal point.*) After the second button pushing operation, the unit goes back to normal display mode.

CONNECTIONS

As depicted in the drawing showing the rear view of the Libra Counter, there are two terminal blocks where all wiring connections are made. All conductors should meet voltage and current ratings for each terminal. Also, cabling should conform to appropriate standards of good installation, local codes and regulations. It is recommended that power supplied to the unit (AC or DC) be protected by a fuse or circuit breaker. The blocks can be removed for easy access to the terminal screws. To remove the block, pull from the back of the block until it slides clear of the terminal block shroud.

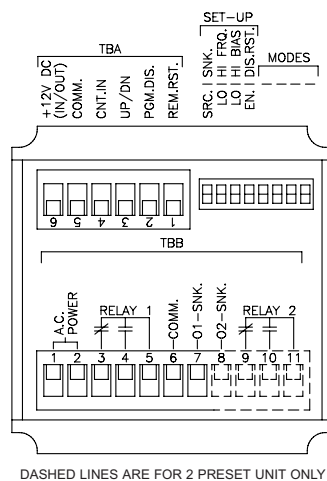

Caution: The terminal blocks should **NOT** be removed with power applied to the unit.

All the DC power and input connections are made to the top terminal block labeled TBA. The AC power and output connections are made to the bottom terminal block labeled TBB. The input connections will be discussed first, using the drawing as a guide.

(*The input connections are the same for 1 or 2 preset counters.*)

EMC INSTALLATION GUIDELINES

Although this unit is designed with a high degree of immunity to ElectroMagnetic Interference (EMI), proper installation and wiring methods must be followed to ensure compatibility in each application. The type of the electrical noise, source or coupling method into the unit may be different for various installations. It should be noted that the methods listed below may not be necessary for every unit installation. In extremely high EMI environments, additional measures may be needed. The unit becomes more immune to EMI with fewer I/O connections. Cable length, routing and shield termination are very important and can mean the difference between a successful installation or a troublesome installation. Listed below are some EMC guidelines for successful installation in an industrial environment.

1. Use shielded (screened) cables for all Signal and Control inputs. The shield (screen) pigtail connection should be made as short as possible. The connection point for the shield depends somewhat upon the application. Listed below are the recommended methods of connecting the shield, in order of their effectiveness.
 - a. Connect the shield only at the panel where the unit is mounted to earth ground (protective earth).
 - b. Connect the shield to earth ground at both ends of the cable, usually when the noise source frequency is above 1 MHz.

- c. Connect the shield to common of the unit and leave the other end of the shield unconnected and insulated from earth ground.
2. Never run Signal or Control cables in the same conduit or raceway with AC power lines, conductors feeding motors, solenoids, SCR controls, and heaters, etc. The cables should be run in metal conduit that is properly grounded. This is especially useful in applications where cable runs are long and portable two-way radios are used in close proximity or if the installation is near a commercial radio transmitter.
3. Signal or Control cables within an enclosure should be routed as far away as possible from contactors, control relays, transformers, and other noisy components.
4. In extremely high EMI environments, the use of external EMI suppression devices, such as ferrite suppression cores, is effective. Install them on Signal and Control cables as close to the unit as possible. Loop the cable through the core several times or use multiple cores on each cable for additional protection. Install line filters on the power input cable to the unit to suppress power line interference. Install them near the power entry point of the enclosure. The following EMI suppression devices (or equivalent) are recommended:
Ferrite Suppression Cores for signal and control cables:
Fair-Rite # 0443167251 (RLC #FCOR0000)
TDK # ZCAT3035-1330A
Steward #28B2029-0A0
Line Filters for input power cables:
Schaffner # FN610-1/07 (RLC #LFIL0000)
Schaffner # FN670-1.8/07
Corcom #1VB3
Corcom #1VR3

Note: Reference manufacturer's instructions when installing a line filter.

5. Long cable runs are more susceptible to EMI pickup than short cable runs. Therefore, keep cable runs as short as possible.
6. Switching of inductive loads produces high EMI. Use of snubbers across inductive loads suppresses EMI.
Snubbers:
RLC #SNUB0000

DC POWER AND INPUT CONNECTIONS

Terminal number 6 on TBA (*the first terminal from the left*), is the +12 VDC input/output terminal. As an output this terminal is for sensor supply and can provide up to 150 mA of current. As an input, an external 11 to 14 VDC supply can be applied to this terminal to power the unit in the absence of AC power. Terminal 5 is the common terminal which the common line from the sensor and other inputs are connected. (*Do NOT connect relay commons or solid-state output commons to this point.*) Terminal 4 is the count input terminal. When the signal at this terminal is pulled low (*zero volts*), a count will be registered. (*See Count Input and Count Rates under the Specifications section.*) Terminal number 3 is the UP/DN terminal (*Count Direction Control*). When this terminal is at a high level, the count direction is "UP". When the terminal is grounded, the count direction is "DOWN". Terminal 2 is the Program Disable (PGM. DIS.) terminal. When this terminal is at a high level, the Preset value(s) and timed output value(s) can be changed using the front panel buttons. (*Outputs can also be tested during self-test under this condition. See Self-Test description for further details.*) When terminal 2 is at a low level (*connected to COMM*), changing these values and testing the outputs is no longer possible. Terminal 1 is the Remote Reset terminal. When this terminal is at a low level (*connected to COMM*), the unit will reset, and the outputs will turn off (*if activated*). As long as reset is low, the unit is held at reset.

AC POWER AND OUTPUT CONNECTIONS

As mentioned before, AC power and output connections are made to the bottom terminal block, labeled TBB. Primary A.C. power is connected to terminal 1 and 2 (*marked A.C. Power, located on the left-hand side of terminal block TBB*). For best results, the A.C. Power should be relatively "clean" and within the specified $\pm 10\%$ variation limits. Drawing power from heavily loaded circuits or from circuits that also power loads that cycle on and off, should be avoided.

Terminals 3, 4, and 5 are used to connect to the output relay 1. Terminal 3 is the normally closed contact. Terminal 4 is the normally open contact. Terminal 5 is the output relay common. Terminal 6 is an output common used for the solid-state output(s). This terminal should NOT be used as the common for the output relay(s) or as the common for the input or control terminals. Terminal 7 is current sinking output 1 (*labeled 01-SNK.*). This internally connects to an NPN Open Collector transistor. The remaining terminals are for the dual preset version of the Libra counter and serve the same functions as those for the single preset unit. Terminal 8 is current sinking output 2 (*labeled 02-SNK.*). Terminal 9 is the normally closed contact of relay 2. Terminal 10 is the normally open contact. Terminal 11 is the output relay common.

FRONT PANEL FUNCTION DESCRIPTION

These units employ six front panel buttons for control and data entering. The button functions are described below.

RESET "R" - This button resets the counter to either zero or preset, depending on the mode of operation selected. For this button to operate, the enable/disable reset button switch, at the rear of the unit, must be set to the enable (EN) position. This button is also used in conjunction with the two preset buttons (one button on the single preset unit) to view and change the timed output value. (When reset is activated, all processes are stopped or interrupted. I.E. outputs turn off, count stops, display is halted, etc.) This is the case under any mode of operation, in any data entry mode.

PRESET "1" ("2") - The preset buttons are labeled and are the two left-hand buttons of the top row, located on the front of the unit. (For the single preset unit, the left-most button is the preset button.) When the "1" button is pressed, preset 1 is displayed. When the "2" (if available) button is pressed, preset 2 is displayed. These values will remain displayed for approximately 10 sec. after release of the button. Also, the preset buttons are used in conjunction with the reset button, to view and change the timed output values. (See "To Enter A New Timed Output Value" section.)

ENTER "E" - This button is used in the "Preset Enter" mode and in the "Timed Output Enter" mode. After the desired value is obtained on the display, this button is pressed which then enters the value into the internal processor. This new value, at that instant, is used in the processing of preset or timed output values. "E" is also used at the end of self-test to exit self-test.

TO ENTER A NEW PRESET VALUE

FIRST: Press "1" (or "2", if a two preset unit). This will display the respective preset value and it will remain displayed for approximately 10 sec. after release of the last button pushed. (At this time, preset display mode can be exited without change, by pressing the "E" button.)

SECOND: Once the preset value is displayed, changing the digit value can be done by pressing the button directly beneath the digit position to be changed. (This value cannot be changed when "PGM. DIS." is activated.) Each time the button is pressed, the digit will increment by one. Also, pressing and holding the button will continuously scroll the digit from 0 through 9, then back to 0 again. When the desired value for that digit is reached, release the button. Do this for all the digits to be changed.

THIRD: Press the "E" (Enter) button to enter the value into the unit's memory. **As soon as** the "E" button is pressed, this new value is used as the operating data. This means, if the preset value is entered, and the old or new value has not been reached, the new value will be used without process disruption (Preset on the fly). If the "E" button is not pressed within 10 sec. after the last digit has been changed, the value will disappear (go back to normal display mode) and the unit will continue to operate on the previous value. During the displaying, changing, and entering of a new preset value, all functions of the unit are operational, such as, counting, resetting, outputs firing, etc. Note: For RTP modes of operation, "1" ("2" for dual preset units) will determine the "Start Count" value of each cycle.

TO ENTER A NEW TIMED OUTPUT VALUE

FIRST: Press and hold the "1" (or "2", for two preset units) button and then press the "R" (Reset) button. At this time, the respective timed output value will be displayed and will remain displayed for approximately 10 sec. after release of the last button pushed. (At this time, the timed output display mode can be exited without change, by pressing the "E" button.)

SECOND: Once the timed output is displayed, changing the digit value can be done by pressing the button directly beneath the digit position to be changed. (This value cannot be changed when "PGM. DIS." is activated.) Each time the button is pressed, the digit will increment by one. Also, pressing and holding the button will continuously scroll the digit from 0 through 9, then back to 0 again. When the desired value for that digit is reached, release the button. Do this for all the digits to be changed. (This value can be set between 0.01 sec and 99.99 sec.)

THIRD: Press the "E" (Enter) button to enter the value into the unit's memory. **As soon as** the "E" button is pressed, this new value is used as the operating data. If the "E" button is not pressed within 10 sec. after the last digit has been changed, the value will disappear (go back to normal display mode) and the unit will continue to operate on the previous value. During the displaying, changing, and entering of a new timed output value, all functions of the unit can be done, such as counting, resetting, output firing etc. without any interruption.

INITIAL POWER-UP & FACTORY SETTINGS

When the unit is shipped from the factory, the values and the following modes are set as shown.

Preset 1	=	500
Preset 2	=	1,000 (if a dual preset version)
Count value	=	0
Timed output value(s)	=	0.1 second

DIP SWITCH SETTINGS

All switches are in the "UP" position except for the reset enable switch, which is "DOWN". With the switches set in these positions, the unit is operating in mode zero (latch-on at preset, manual reset to zero). The input is set for sinking type inputs, high frequency, and high bias operation.

TROUBLESHOOTING

For further technical assistance, contact technical support at the appropriate company numbers listed.

SELF-TEST

This unit has a built-in, self-test feature, which can be activated without losing counts, preset values, missing preset points, timed output durations, or interfering with control functions. With this test, all digits are cycled through, then the mode select switch settings are displayed. At this point, the outputs can also be tested.

To enter self-test, press the two upper right-hand digit buttons (located on the front panel), simultaneously. At this time, whatever count value was displayed will disappear and be replaced by a string of four zeros. This will be shown for about half a second, then a string of ones will appear for the same time duration. Following these, a string of twos and so on, up to nine will be displayed. After the nines are shown, three decimal points will appear. After this portion, an interlace pattern of the same numbers will be shown. First, a combination of 1, 0, 1, 0 then 1, 2, 1, 2 and so on, until all digits from zero to nine have been displayed.

The next portion of self-test will display a group of ones and zeros. These ones and zeros are the settings of the mode select switches (the four right-hand DIP switches only). This pattern directly corresponds to the number representing the mode of operation. If the switches are changed while at this point in the self-test, the settings can be seen to change. These changes will not affect counter operation immediately, but any changes will take effect when self-test is exited. When the switch is "DOWN", the display will show a one. When the switch is "UP", the display will show a zero. If no testing of the outputs is required, press the "E" button until the unit exits self-test (the unit will go back to the count display mode). Also, if no activity occurs on the switches or the front panel buttons within 18 sec. after the unit pauses at the mode switch display, the unit will automatically exit the self-test.

During the time the mode switch settings are displayed, the outputs can be tested. To activate the outputs, press the "1" button (for dual preset version, "1" or "2" is pressed).

Note: The "PGM. DIS." terminal must be at a high level for the outputs to be activated. Also, caution should be used when testing the outputs, so as not to cause any undesirable or hazardous conditions in the system. (To turn off the outputs, release the button.)

If the outputs are not tested, the state of the outputs will remain the same as it was prior to self-test. If the outputs are tested in self-test, the outputs will be turned off after exiting self-test.

Rapid advance of the self-test routine can be done by pressing and releasing any of the front panel buttons except for the "R" button. (Pressing "R" at any time, except when entering the timed output mode, will reset the unit.)

CONNECTIONS & CONFIGURATION SWITCH SET-UPS FOR VARIOUS SENSOR OUTPUTS

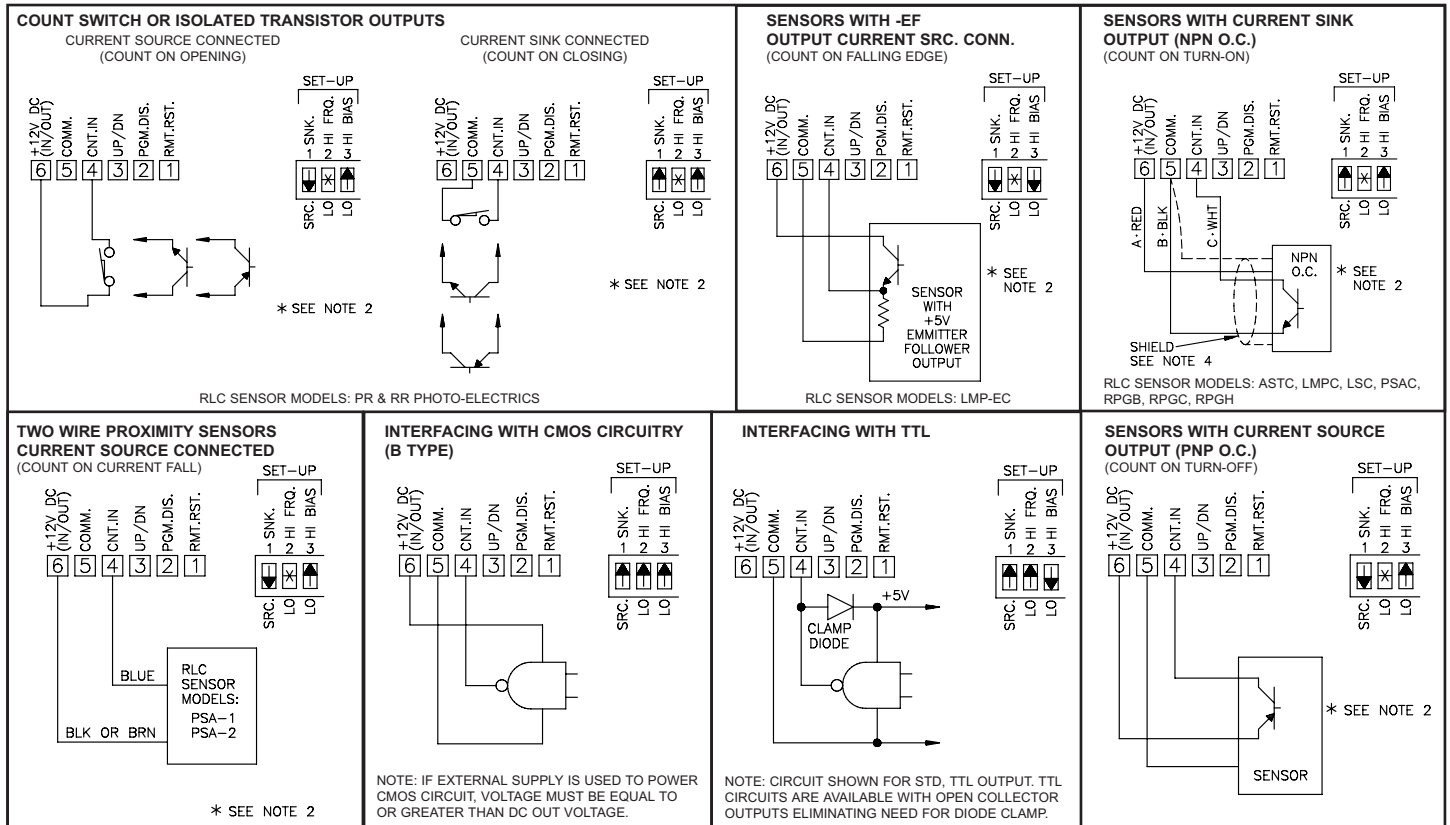

NOTES:

- 1. SENSOR SUPPLY VOLTAGE AND CURRENT**
The +12 V sensor supply voltage on the "+12 VDC" Terminal is nominal with $\pm 25\%$ variation due to line and internal load variations. All RLC sensors will accommodate this variation.
- 2. HI/LO FRQ. SELECTION**
The HI/LO FRQ Selection switch must be set on LO FRQ when switch contacts are used to generate count input signals. Since the LO FRQ mode also provides very high immunity against electrical noise pickup, it is recommended that this mode also be used, whenever possible, with

- electronic sensor outputs, as added insurance. The LO FRQ mode can be used with any type of sensor output, provided the count pulse widths never decrease below 5 milliseconds, and the count rate does not exceed 100 Hz.
- V_{IL} and V_{IH} levels given are nominal values $\pm 10\%$, when the counter voltage at the "+12 VDC" Terminal, is +12 VDC. These nominal values will vary in proportion to the variations in "+12 VDC" Terminal voltage, caused by line voltage and load changes.
- When shielded cable is used, the shield should be connected to COMM. at the counter and left unconnected at sensor end.

INSTALLATION ENVIRONMENT

The unit should be installed in a location that does not exceed the maximum operating temperature and provides good air circulation. Placing the unit near devices that generate excessive heat should be avoided.

The bezel should be cleaned only with a soft cloth and neutral soap product. Do NOT use solvents.

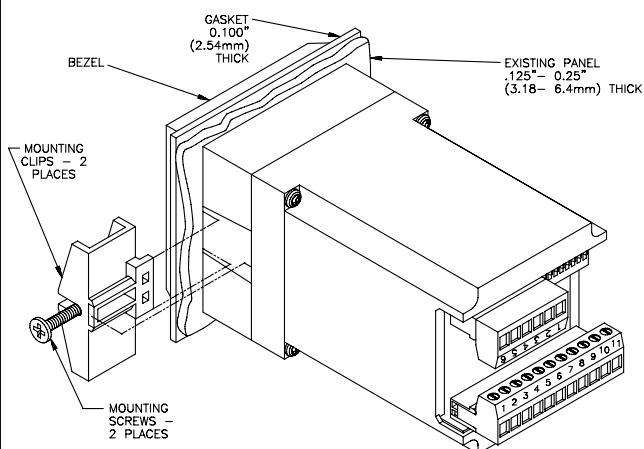

Continuous exposure to direct sunlight may accelerate the aging process of the bezel.

Do not use tools of any kind (screwdrivers, pens, pencils, etc.) to operate the keypad of the unit.

Installation

The Libra counters meet NEMA 4/IP65 requirements for indoor use, when properly installed. The units are intended to be mounted into an enclosed panel with a gasket to provide a water-tight seal. Two mounting clips and screws are provided for easy installation. Consideration should be given to the thickness of the panel. A panel that is too thin may distort and not provide a water-tight seal. (Recommended minimum panel thickness is 1/8" {3.2 mm}.)

After the panel cut-out has been completed and deburred, carefully apply the gasket to the panel. **DO NOT APPLY THE ADHESIVE SIDE OF THE GASKET TO THE COUNTER BEZEL.** Insert the unit into the panel. As depicted in the drawing (at right), install the screws into the narrow end of the mounting clips. Thread the screws into the clips until the pointed end just protrudes through the other side. Install each of the two mounting clips by inserting the wide lip of the clips into the front end of the hole, located on either side of the case. Then snap the clip onto the case. Tighten the screws evenly to apply uniform compression, thus providing a water-tight seal.

Caution: Only minimum pressure is required to seal panel. Do NOT overtighten mounting screws.

