

MODEL PSDR - 24 V POWER SUPPLIES @ 1, 2, OR 4 A



DESCRIPTION

The compact PSDR power supplies are industrial input voltage supplies with primary switched-mode regulator technology. They feature low output ripple and adjusted output voltage from 22.5 to 28.5 VDC. The output is electronically protected against overloads and short circuits.

The modules snap onto standard 35 mm flat DIN rails and use removable terminal blocks for easy wiring.

SPECIFICATIONS

1. POWER REQUIREMENTS:

Nominal Input Voltage: 100 to 240 VAC

Input Voltage Range: 85 to 264 VAC or 90 to 350 VDC

Current Consumption at nominal input voltage:

PSDR0100: 0.5 A to 0.2 A @ 100 to 240 VAC, 0.4 to 0.1 A @ 90 to 350 VDC

PSDR0200: 0.82 A to 0.33 A @ 100 to 240 VAC, 0.65 to 0.19 A @ 90 to 350 VDC

PSDR0400: 1.8 A to 0.7 A @ 100 to 240 VAC, 1.3 to 0.4 A @ 90 to 350 VDC

2. FREQUENCY: 50 to 60 Hz

3. INPUT RECOMMENDED BACKUP FUSE:

Power Circuit Breaker: 6 A or 10 A

Characteristic: B (EN 60898)

4. SURGE VOLTAGE PROTECTION: Varistor

5. POWER OUTPUT: Nominal value of 24 VDC ±1%. Adjustable from 22.5 to 28.5 VDC via potentiometer

6. EFFICIENCY AT 230 VAC AND NOMINAL VALUES: > 80 %

7. ENVIRONMENTAL CONDITIONS:

Operating Temperature Range: -25 to 60°C

Storage Temperature: -40 to 85°C

Humidity, no moisture condensation: 95 % at 25°C

Vibration in acc. with IEC 68-2-6: < 15 Hz, amplitude ±2.5 mm;

15 Hz - 150 Hz, 2.3 g

Shock in all directions acc. with IEC 68-2-27: 30 g

Contamination in acc. with EN 50178: Degree of pollution 2

8. STANDARDS AND CERTIFICATIONS:

Electrical Safety (of information technology equipment)	EN 60950 / VDE 0805 UL Recognized UL 60 950
Industrial regulating devices	UL 508 listed
Electronic equipment for use in electrical power installations (surge voltage category III)	EN 50178 / VDE 0160
Limitation of output power	NEC Class 2
Safe isolation	VDE 0100-410
Protection against electric shock	DIN VDE 0106-101

DIMENSIONS In inches (mm)

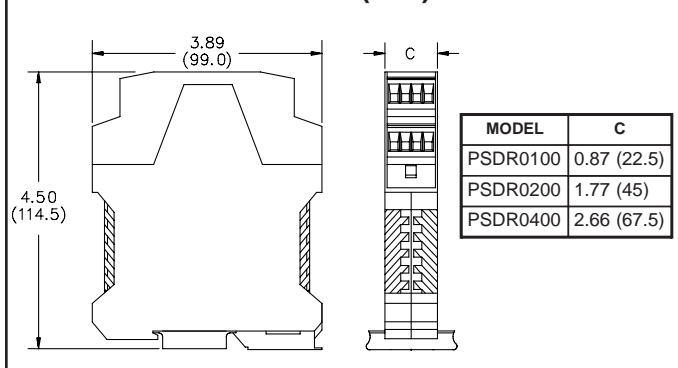

CE In conformance with EMC guideline 89/336/EEC and low-voltage directive 73/23/EEC

EMC (Electromagnetic compatibility)

Immunity in accordance with EN 61000-6-2

Discharge of static electricity (ESD)	EN 61000-4-2 ²⁾	Housing > Level 3 Contact discharge: 8 kV Discharge in air: 8 kV
Electromagnetic HF field	EN 61000-4-3 ¹⁾	Housing Level 3 Frequency/Field intensity: 80-1000 MHz / 10 V/m
Fast transients (Burst)	EN 61000-4-4 ²⁾	Input: 4 kV (Level 4) ⁴⁾ Output: 2 kV (Level 3) ⁴⁾ Signal: 1 kV (Level 2) ⁴⁾
Surge voltage capacities (Surge)	EN 61000-4-5 ²⁾	Input: 4 kV ⁴⁾ / 2 kV ⁴⁾ (Level 4) Output: 0.5 kV ⁴⁾ / 0.5 kV ³⁾ (Level 1) Signal: 0.5 kV ⁴⁾ (Level 1)
Conducted disturbance	EN 61000-4-6 ¹⁾	I/O/S: Level 3 Frequency/U ₀ : 0.15-80 MHz / 10 V
Voltage dips	EN 61000-4-11 ²⁾	Input: see mains buffering > 20 ms
Simulation mobile phones	ENV 50204	Frequency: 900 MHz, 1800 MHz Field intensity: 20 V/m

Noise emission according to EN 50081-2

Emitted radio interference	EN 55011 (EN 55022) Class B ⁵⁾
Radio interference voltage	EN 55011 (EN 55022) Class B ⁵⁾

EN 55011 corresponds to CISPR11 / EN 55022 corresponds to CISPR22
 EN 61000 corresponds to IEC 1000

- 1) Criterion A: Normal operating behavior within the defined limits.
- 2) Criterion B: Temporary impairment to operational behavior, that is corrected by the device itself.
- 3) Symmetrical: Conductor to conductor.
- 4) Asymmetrical: Conductor to ground.
- 5) Class B: Area of application industry and residential.

9. ISOLATION VOLTAGE: Input/Output 3 kVAC

10. INSTALLATION POSITION: On horizontal mounting rail according to EN 50022-35

11. CONNECTIONS: 24 to 14 AWG max. Torque 4.5 to 5.3 inch-lbs (0.5-0.6 Nm).

12. MOUNTING: Standard DIN rail top hat (T) profile rail according to EN50022 - 35 X 7.5 and 35 X 15. Can be mounted in rows with vertical Spacing > 5 cm or horizontally with no space.

13. CONSTRUCTION: Case body is black, high impact plastic. IP20 touch safe. Protection Class II.

14. MTBF (Mean Time Between Failure): >500000 h in acc. with IEC 1709 (SN 29500)

15. WEIGHT:

- PSDR0100: 7.4 oz. (210 g)
- PSDR0200: 8.8 oz. (250 g)
- PSDR0400: 14.1 oz. (400 g)

CONNECTION AND OPERATION INSTRUCTIONS

Caution: Danger! Never work on live equipment!
Caution: When the device is opened, a dangerous voltage may remain at the electrolytic capacitors for up to 2 minutes after shutdown!

The installation must be performed by a specialist in accordance with the requirements of EN 60950.
 For vertical installations we recommend a minimum spacing of 5 cm (1.97 in.) between other modules and this power supply to ensure sufficient convection.
 No minimum spacing is required for horizontal alignment.
 The mains feed line must have an appropriate fixing or strain relief outside of the device.
 The supply-side installation and the connection via screw terminal blocks must be done in a way that ensures protection against electric shock.

PROTECTION

The device must be installed in accordance with the specifications of EN 60950.

It must be possible to switch off the device using a suitable disconnecting device outside the power supply. For example, primary side line protection could be used.

In case of DC applications it is necessary to connect in series an adequate fuse.

RAIL MOUNTING

The power supply unit can be snapped onto all mounting rails in accordance with EN 50022-35. Installation should be made horizontally (input terminal blocks below).

CABLE CONNECTION

The device is equipped with COMBICON plug connectors. This easy-to assemble connection method allows devices to be exchanged easily and the electrical connection to be visibly isolated.

Connecting Cables:

Cable cross sections from 0.2 to 2.5 mm² rigid (solid)/flexible (stranded) (AWG 24-14) may be used.

To maintain UL, use copper cable rated for an operating temperature of 75°C/170°F.

For Reliable And Touch-proof Contacts:

Strip the connection ends (7 mm - See Figure).

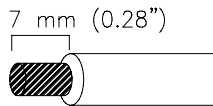

ORDERING INFORMATION

MODEL NO.	OUTPUT	PART NUMBER
PSDR1	24 VDC @ 1A	PSDR0100
PSDR2	24 VDC @ 2A	PSDR0200
PSDR4	24 VDC @ 4A	PSDR0400

INPUT

The input connection is made by the screw connections “L(+)” and “N(-)” (torque 0.5 Nm) on the COMBICON plug connection.

For device protection, there is an internal fuse. Additional device protection is not necessary.

Recommended backup fuses are power circuit-breakers 6 A or 10 A, characteristic B (or identical function). In DC applications, a suitable backup fuse must be wired in.



If the internal fuse is triggered, there is most probably a malfunction in the device. In this case, the device must be inspected in the factory!

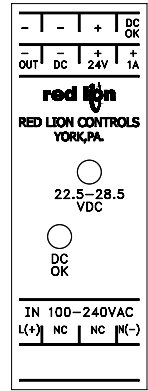

OUTPUT

The 24 VDC connection is made by the screw connections “+” and “-” (torque 0.5 Nm) on the COMBICON plug connection. At the time of delivery, the output voltage is 24 VDC. The output voltage can be set from 22.5 to 28.5 VDC on the potentiometer.

The device is electronically protected against short circuits and idling. In the event of an error, the output voltage is limited to max 35 VDC.

Function Monitoring

For function monitoring, there is the active DC OK switching output and the DC OK LED.

The 24 VDC signal is measured between the “DC OK” and “-” connection terminal blocks and can be loaded with 20 mA maximum. This signal output indicates that the output voltage has fallen below 21.5 VDC when “active high” changes to “low”.

The DC OK signal is isolated from the power output.

	STATUS 1	STATUS 2
Green LED “ DC OK”	on	off
Active DC OK switching output	U = +24 V (in reference to “-”)	U = 0 V (in reference to “-”) U _{OUT} ≤ 21.5 V
Status	Normal operation of the power supply. U _{OUT} > 21.5 V	• Secondary consumer short-circuit or overload • No mains voltage or device faulty

Output Characteristic Curve

The device functions following the U-I characteristic curve. Under load, the operating point follows this curve. In the event of a short circuit or overload, the output current is limited to I_{BOOST}. The secondary voltage is reduced until the short circuit on the secondary side has been remedied.

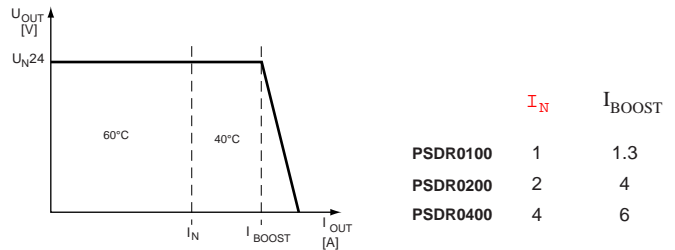

Thermal Behavior

In the case of ambient temperatures above +60°C, the output capacity has to be reduced by 2.5% per Kelvin increase in temperature.

From +70°C or a thermal overload, the device reduces the output power for its own protection, and returns to normal operation when it has cooled down.