

## SUB-CUB2-8A - 8-DIGIT COMPONENT COUNTER



- SUB-CUB2-8A - 8-DIGIT COMPONENT COUNTER
- LSI COUNTER CHIP AND 0.30" (7.62 mm) HIGH LCD DISPLAY
- SOLDERLESS, ELASTOMERIC INTERCONNECTS  
(Snap Mounts Directly Onto P.C. Board)
- LATCHABLE DISPLAY WITH SELECTABLE LEADING ZERO BLANKING
- COUNT RATES TO 750 KHZ
- LOW POWER, 40  $\mu$ A AT 5 V (Typical)

\* ACCESSORY HARDWARE AVAILABLE FOR PANEL MOUNTING SUB-CUB2-8A

### DESCRIPTION

The SUB-CUB2-8A is a completely self-contained 8-digit LCD counter/display module. The module can be treated as a component just like any other I.C. The SUB-CUB2-8A can be used in simple high speed counting applications as well as more complex applications such as frequency meters, pulse width meters, etc.

Since it is a P.C. Board mounted component, the SUB-CUB2-8A is easily integrated into applications where a readout of count, frequency, or time is needed within a circuit enclosure. The SUB-CUB2-8A bezel and interface

board can be used to provide a convenient and economical panel mounted display.

The SUB-CUB2-8A snap-mounts directly onto any 1/16" P.C. Board that has been etched to provide a mating interconnect pad pattern and drilled for two mounting holes and a polarizing "key" hole. Interconnections to the P.C. Board as well as internal connections are made with elastomeric connectors that provide an easy, corrosion-proof, and gas-tight interface for high reliability.

### MOUNTING & DIMENSIONS

Snap in mounting on the P.C. Board is facilitated by two, split, lock-ramp pins which engage mounting holes drilled in the P.C. Board. The silicone rubber elastomeric connectors compress to accommodate P.C. Board thickness variations of  $\pm 0.005$ " (0.13 mm).

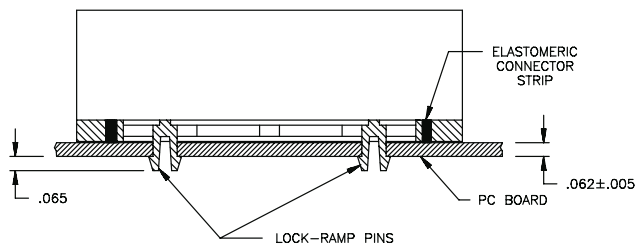

### DIMENSIONS "In Inches (mm)"

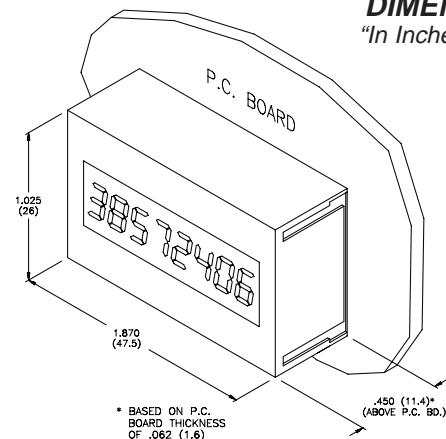

### P.C. BOARD LAYOUT

P.C. Board pads may be gold or tin-lead plated. Pad surface must be flat without excessive tin-lead build-up. (Layout view is from the SUB-CUB2-8A mounting side of the board.)

Pad area must be clean and free of contaminants so that proper electrical contact can be made.

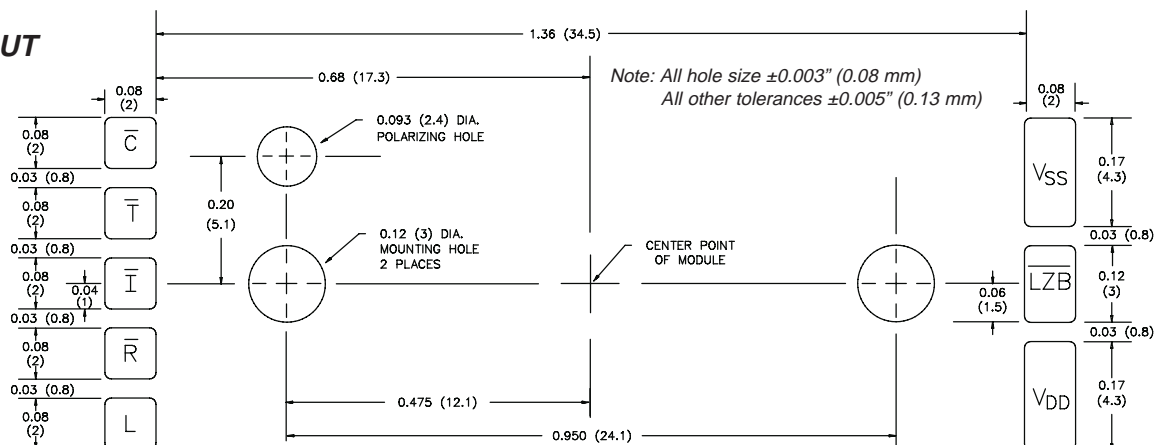

## DEVICE CONNECTIONS \*

**COUNT ( $\bar{C}$ )** - CMOS Schmidt Trigger input, counter increments on falling edge of count pulse.

**TEST ( $\bar{T}$ )** - CMOS level-sensitive. When the input is "HIGH", the counter operates normally. When pulled "LOW", the carry input to each decade is disconnected and tied to the count input so that all decades count in parallel to provide rapid testing.

**INHIBIT ( $\bar{I}$ )** - CMOS level-sensitive, a "LOW" level will prevent the counter from accepting pulses at the "COUNT" input. A "HIGH" level will enable the counter.

**RESET ( $\bar{R}$ )** - CMOS level-sensitive, a "LOW" level will reset the counter to 0 (or to 00000000 if LZB is disabled). A "HIGH" level will allow the counter to operate normally.

**LATCH ( $\bar{L}$ )** - CMOS level-sensitive, a "HIGH" level will latch the data in the display drivers while the counter registers can continue to update. A "LOW" level will allow the display driver to update with the counter registers.

$V_{SS}$  - Common for D.C. Supply and Inputs.

**LEADING ZERO BLANKING ( $\bar{LZB}$ )** - CMOS level-sensitive, a "LOW" level will enable leading zero blanking. A "HIGH" level will display leading zeros. LZB can only be changed at power up.

$V_{DD}$  - Positive side of D.C. Supply.

\* All unused inputs must be tied to either  $V_{DD}$  or  $V_{SS}$ , whichever is appropriate.

## BLOCK DIAGRAM

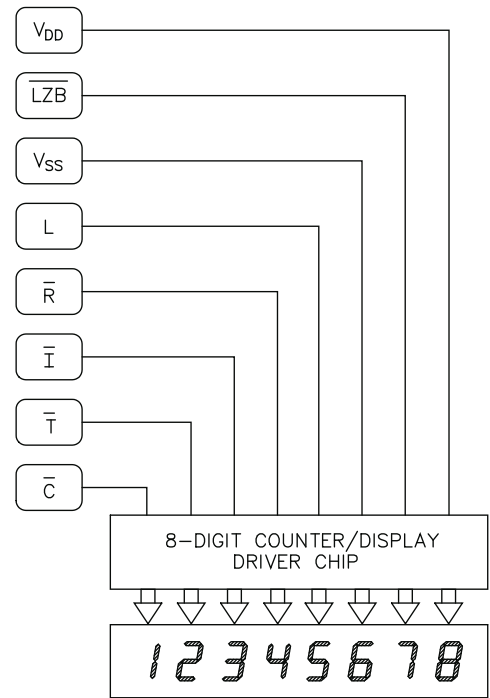

## CAUTION

The SUB-CUB2-8A contains CMOS circuitry and has the same protection circuits as standard CMOS devices, to prevent damage to inputs due to nominal over-voltage. This device requires special anti-static handling to the same degree required by standard CMOS integrated circuits. Units should be stored in the conductive packaging used to ship the devices. Containers should be opened and the units handled only on a conductive table top by personnel wearing wrist strap grounding equipment.

## MAXIMUM RATINGS (VOLTAGE REF. TO $V_{SS}$ )

RATING	SYMBOL	VALUE	UNIT
DC Supply Voltage	$V_{DD}$	-0.5 to +6.5	VDC
Input Voltage, All Inputs	$V_I$	-0.5 to ( $V_{DD} + 0.5$ )	VDC
Operating Temperature	$T_A$	-20 to +85	°C
Storage Temperature	$T_{STG}$	-20 to +85	°C

## ELECTRICAL CHARACTERISTICS $V_{DD} = 5 V \pm 10\% @ 25^\circ C$ UNLESS OTHERWISE SPECIFIED

SYMBOL	PARAMETER	MIN.	TYP.	MAX.	UNIT	TEST CONDITION
$V_{DD}$	Supply Voltage	4.5	5 V	5.5	VDC	
$I_{DD}$	Supply Current		50	100	$\mu A$	$F_C = 10$ KHz
$I_{DDQ}$	Quiescent Current		40	100	$\mu A$	Not Counting
$V_{IH}$	Input Voltage - High	3.5	2.9		VDC	Count, Reset & Latch Input Only
$V_{IL}$	Input Voltage - Low		1.3	1.0	VDC	Count, Reset & Latch Input Only
$V_{IH}$	Input Voltage - High	3.0	1.9		VDC	Test, Inhibit, & LZB Input Only
$V_{IL}$	Input Voltage - Low		1.9	1.0	VDC	Test, Inhibit, & LZB Input Only
$I_{IL}$	Input Leakage Current		0.1	1.0	$\mu A$	
$F_C$	Count Frequency (50% Duty Cycle)	750	1000		KHz	50% Duty Cycle
$T_R$	Reset Pulse Width	10	0.5		$\mu S$	
$T_L$	Latch Pulse Width	10	0.5		$\mu S$	

## ORDERING INFORMATION

MODEL NO.	DESCRIPTION	PART NUMBER
SCUB28A	SUB-CUB2-8A Display/Counter Module	SCUB28A0
HWK 28	*Panel Bezel Kit with P.C. Board & Cable	HWK28000
HWK 3	*Panel Bezel Kit w/o P.C. Board & Cable	HWK30000

\* - Does not include SUB-CUB2-8A Display/Counter Module (Order SUB-CUB2-8A Separately).

## PANEL BEZEL KIT FOR THE SUB-CUB2-8A (P/N HWK28000)

This kit provides a convenient way to adapt the SUB-CUB2-8A for panel mounting. The kit includes the black bezel, the panel and internal window gaskets, P.C. Board, 12" ribbon cable and mounting screws.

### ASSEMBLY

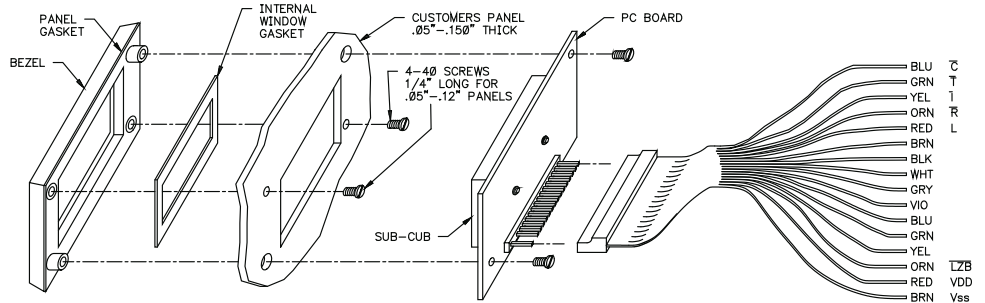

### DIMENSIONS & PANEL CUT-OUT "In inches (mm)

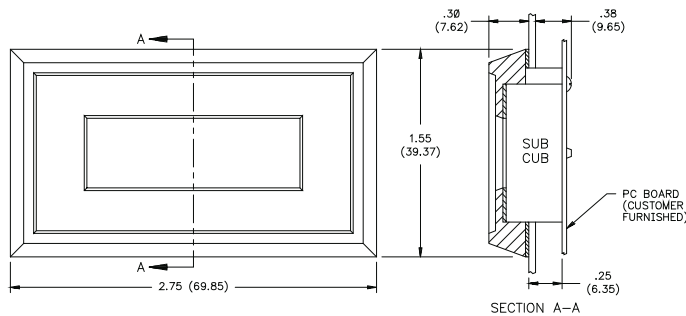

### PANEL CUT-OUT FRONT VIEW

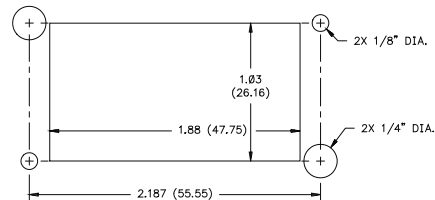

### EIGHT-DIGIT TOTALIZER

This circuit is used to totalize the number of relay contact closures for the purpose of determining the operating life of a relay.

The relay is energized by a pulsed external voltage. The normally open contact of the relay is connected to the signal input of the circuit. The resistors R1 and R2, along with C1, provide filtering to prevent contact bounce from registering false counts. The SUB-CUB2-8A can be cleared by pressing the "RESET" button. Note that all unused inputs are tied to either "V<sub>SS</sub>" or "V<sub>DD</sub>", whichever is appropriate.

